

OCTOBER 1979 Volume 4, Number 10 \$2.00 in USA/\$2.40 in Canada

BYTE[®]

the small systems journal
A MCGRAW-HILL PUBLICATION

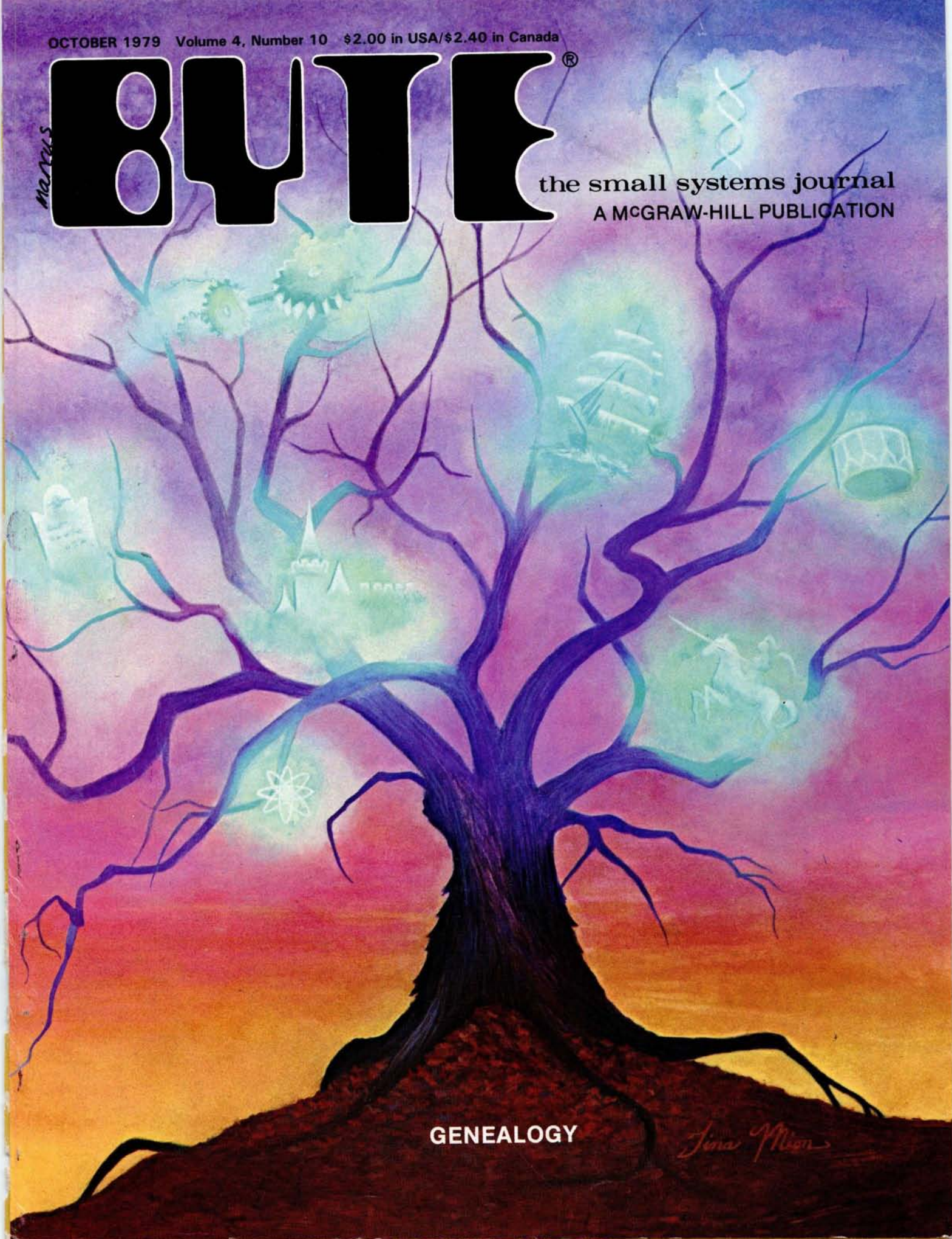

GENEALOGY

Jana Miller

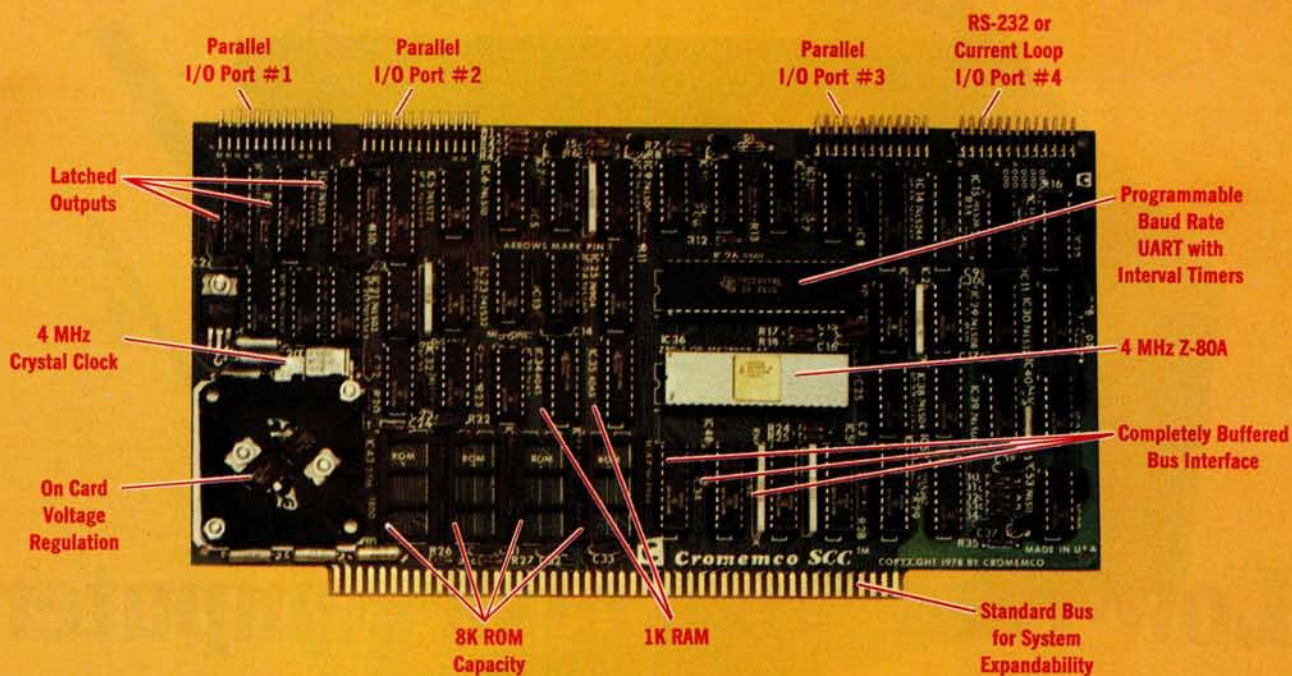

The single card computer with the features that help you in real life

COMPLETE COMPUTER

In this advanced card you get a professional quality computer that meets today's engineering needs. And it's one that's complete. It lets you be up and running fast. All you need is a power supply and your ROM software.

The computer itself is super. Fast 4 MHz operation. Capacity for 8K bytes of ROM (uses 2716 PROMs which can be programmed by our new 32K BYTESAVER® PROM card). There's also 1K of on-board static RAM. Further, you get straightforward interfacing through an RS-232 serial interface with ultra-fast speed of up to 76,800 baud — software programmable.

Other features include 24 bits of bi-directional parallel I/O and five on-board programmable timers.

Add to that vectored interrupts.

ENORMOUS EXPANDABILITY

Besides all these features the Cromemco single card computer gives you enormous expandability if you ever need it. And it's easy to expand. First, you can expand with the new Cromemco 32K BYTESAVER PROM card mentioned above. Then there's Cromemco's broad line of S100-bus-compatible memory and I/O interface cards. Cards with features such as relay interface, analog interface, graphics interface, optoisolator input, and A/D and D/A conversion. RAM and ROM cards, too.



Card Cage



32K BYTESAVER PROM card

EASY TO USE

Another convenience that makes the Model SCC computer easy to use is our Z-80 monitor and 3K Control BASIC (in two ROMs). With this optional software you're ready to go. The monitor gives you 12 commands. The BASIC, with 36 commands/functions, will directly access I/O ports and memory locations — and call machine language subroutines.

Finally, to simplify things to the ultimate, we even have convenient card cages. Rugged card cages. They hold cards firmly. No jiggling out of sockets.

AVAILABLE NOW/LOW PRICE

The Cromemco Model SCC is available now at a low price of only \$450 factory assembled (\$395 kit).

So act today. Get this high-capability computer working for you right away.



Cromemco
i n c o r p o r a t e d

Specialists in computers and peripherals

280 BERNARDO AVE., MOUNTAIN VIEW, CA 94040 • (415) 964-7400

Foreground

- 22** TRACING YOUR OWN ROOTS *by Stan W Merrill*
Genealogical research with a microcomputer
- 48** POWER HELPS ANALYZE ELECTRIC BILLS *by Karen S Wolfe*
Determine power usage from appliance ratings
- 58** SELF-REFRESHING LED GRAPHICS DISPLAY *by Steve Ciarcia*
Add a digital display to your computer system
- 124** INTERFACING THE S-100 BUS WITH THE INTEL 8255 *by David L Condra*
Design advice for the person starting out in hardware
- 140** THE XYZ PHENOMENON: Stereoscopic Plotting by Computer *by William T Powers*
Three-dimensional simulation using optical devices and computer graphics
- 150** CURVE FITTING WITH YOUR COMPUTER *by Fred R Ruckdeschel*
A simplified approach to nonlinear regression
- 196** SPACE GAME *by Loring C White*
Develop your reflexes with this fast-moving game
- 200** EASY TO USE HASHING FUNCTION *by Don Kinzer*
Random symbol distribution aids recall process

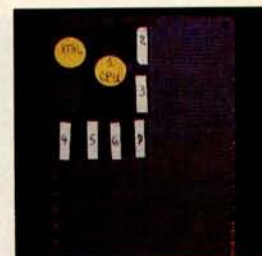

page 6

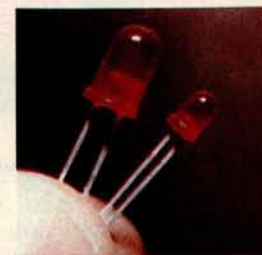

page 58

Background

- 76** PICKING UP THE PIECES *by Alfred S Baker*
Recovering from disk write errors
- 90** VARIABLES WHOSE VALUES ARE STRINGS *by Dr W D Maurer*
String variables can be easy to use
- 100** IBM COMPATIBLE DISK DRIVES *by Jefferson H Harman*
Floppy disk sectoring rules
- 113** THE TRS-80 SPEAKS *by Tim Gargagliano and Kathryn Fons*
Discussion of a vocal output peripheral for the Radio Shack TRS-80
- 168** LOW-LEVEL PROGRAM OPTIMIZATION: Some Illustrative Cases *by James Lewis*
How to decrease memory requirements and increase execution speed
- 186** SOME LAWS OF PERSONAL COMPUTING *by Dr T G Lewis*
Some unnatural, natural laws
- 206** BUDGET BUILDING ON A BARE BOARD *by Dan S Parker*
Building computer systems inexpensively

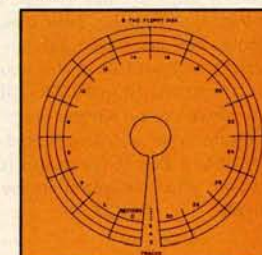

page 76

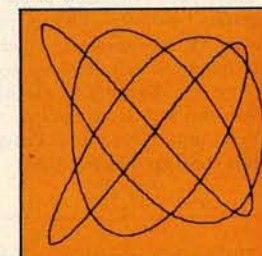

page 140



Nucleus

Editorial, 6
Letters, 16
Technical Forum, 70
BYTE News, 107
Event Queue, 162
Languages Forum, 174
BYTE's Bits, 192
BYTE's Bugs, 209

Clubs and Newsletters Directory, 210
Book Reviews, 242
Programming Quickies, 246
What's New?, 249
Unclassified Ads, 295
Reader Service, 296
BOMB, 296

Cover Art: Genealogy *by Tina Mion*

BYTE is published monthly by BYTE Publications Inc, 70 Main St, Peterborough NH 03458, a wholly-owned subsidiary of McGraw-Hill, Inc. Address all mail except subscriptions to above address: phone (603) 924-7217. Address subscriptions, change of address, USPS Form 3579, and fulfillment questions to BYTE Subscriptions, PO Box 590, Martinsville NJ 08836. Second class postage paid at Peterborough NH 03458 and at additional mailing offices—USPS Publication No. 102410 (ISSN 0360-5280). Subscriptions are \$18 for one year, \$32 for two years, and \$46 for three years in the USA and its possessions. In Canada and Mexico, \$20 for one year, \$36 for two years, \$52 for three years. \$32 for one year air delivery to Europe. \$32 surface delivery elsewhere. Air delivery to selected areas at additional rates upon request. Single copy price is \$2 in the USA and its possessions, \$2.40 in Canada and Mexico, \$3.50 in Europe, and \$4 elsewhere. Foreign subscriptions and sales should be remitted in United States funds drawn on a US bank. Printed in United States of America.

Address all editorial correspondence to the editor at the above address. Unacceptable manuscripts will be returned if accompanied by sufficient first class postage. Not responsible for lost manuscripts or photos. Opinions expressed by the authors are not necessarily those of BYTE. Entire contents copyright © 1979 by BYTE Publications Inc. All rights reserved.

BYTE® is available in microform from University Microfilms International, 300 N Zeeb Rd, Dept PR, Ann Arbor MI 48106 USA or 18 Bedford Row, Dept PR, London WC1R 4EJ ENGLAND.

Subscription WATS Line: (800) 258-5485

Office hours: Mon-Thur 8:30 AM - 4:30 PM
Friday 8:30 AM - Noon

In This BYTE



About the Cover

This month's cover theme is provided by an article on using one's personal computer for personal genealogy tasks, "Genealogy" by Tina Mion. Taking off on this theme, autumn colors, and the day of the great pumpkin at the end of October, artist Tina Mion has created an autumnal tree with some ghostly leaves reflecting a history of science and technology.

Putting you in touch with yourself and improving family relationships are just two of the rewards of **Tracing Your Own Roots**. The microcomputer is a perfect companion in the search for ancestors. Stan W Merrill introduces some simple ways to compile your genealogy, and provides a BASIC program to involve your computer in the quest. *Page 22*

Since your computer is using precious (and often high priced) electricity, it seems only right that it should help analyze your electric bill. Karen S Wolfe has developed a program called **Power**, and tells us how **Power Helps Analyze Electric Bills**. *Page 48*

There are a variety of output devices which could be added to your computer system. One

such device is an LED display. Steve Ciarcia discusses several methods of interfacing an LED display to a computer, and culminates his discussion with a **Self-Refreshing LED Graphics Display**. *Page 58*

Disks provide much more convenient storage than tape. When write errors occur, however, they can also be much more catastrophic. Alfred S Baker provides a brief description of the two main data file organizations used on floppy disks, and also describes a major problem that can occur when using one of them. Don't give up hope. A program is provided which will aid you when **Picking Up the Pieces**. *Page 76*

At some time almost every programmer has wanted to

write a program containing variables whose values are strings. Dr W Douglas Maurer explores two techniques for implementing this task in **Variables Whose Values Are Strings**. *Page 90*

Jefferson H Harman describes how **IBM Compatible Disk Drives** should perform. Not all manufacturers who say that they are IBM compatible mean fully compatible. *Page 100*

The talking computer is now within the grasp of personal computer users. Tim Gargagliano and Kathryn Fons discuss the Votrax voice synthesizer that is available for the Radio Shack TRS-80 in **The TRS-80 Speaks: Using BASIC to Drive a Speech Synthesizer**. *Page 113*

The Intel 8255 programmable peripheral interface is a large scale integration part that makes interface designing easy. David L Condra gives advice on the procedure and includes a design in **Interfacing the S-100 Bus With the Intel 8255**. *Page 124*

Using a principle invented years ago, simulated three-dimensional graphics may be produced on a personal computer equipped with a plotter or similar device. William T Powers explains the method in **The XYZ Phenomenon**. *Page 140*

In **Curve Fitting With Your Computer**, Fred R Ruckdeschel describes a simplified method for obtaining a reasonably

accurate equation as a "best fit" to a collection of data points. *Page 150*

When working with time-critical or memory-critical programs, optimization techniques are often employed. James Lewis discusses some of these in his article on **Low-level Program Optimization: Some Illustrative Cases**. *Page 168*

What is the "Conservation of Agony?" It is one of the rules of personal computing proposed by Dr T G Lewis in his thought provoking article, **Some Laws of Personal Computing**. Read it and find out why Dr Lewis suggests that "software should be shared, but hardware should be replicated." *Page 186*

Loring C White describes a real-time **Space Game** which requires you to maneuver a ship within gun sights and then destroy the enemy. *Page 196*

Hashing is a common method of handling lists, widely used in assemblers and compilers for handling the symbol table. In this issue Don Kinzer discusses an **Easy to Use Hashing Function** for the 6800 microprocessor. *Page 200*

Many companies are offering blank S-100 compatible computer boards. Dan S Parker describes the substantial savings that can be achieved by populating these boards and following some simple guidelines in **Budget Building on a Bare Board**. *Page 206*

Publishers

Virginia Londoner
Gordon R Williamson
Associate Publisher
John E Hayes
Assistant
Jill E Callihan

Editorial Director

Carl T Helmers Jr
Executive Editor
Christopher P Morgan
Editor in Chief
Raymond G A Cote
Senior Book Editor
Blaise W Lifflick

Editors

Richard S Shuford
Gregg Williams
Assistant Editors
Kent Richard
Bob Braisted
Editorial Assistants
Gaie Britton
Faith Ferry
New Products Editor
Clubs, Newsletters
Charles Freiberg

Drafting

Jon Swanson

Production Director

Nancy Estle
Production Editors
David William Hayward
Ann Graves
Faith Hanson
Warren Williamson
Robin M Moss
Anthony J Lockwood
Art Director
Ellen Bingham
Production Art
Wai Chiu Li
Christine Dixon
Holly Carmen LaBosiere
Deborah Porter

Typographers

Cheryl A Hurd
Debe L Wheeler
Sherry McCarthy
Kathy Becker

Advertising Director

Patricia E Burgess
Assistants
Ruth M Walsh
Marion Gagnon
Janet Ames
Eileen Kindl
Adv/Prod Coordinator
Thomas Harvey
Advertising Billing
Noreen Bardsley
Don Bardsley

Circulation Manager

Gregory Spitzfaden
Assistants
Pamela R Heaslip
Agnes E Perry
Melanie Bertoni
Barbara Ellis
Dealer Sales
Ginnie F Boudrieau
Anne M Baldwin
Traffic Department
Mark Sandagata
Thomas Yanni

Receptionist

Jaqueline Earnshaw

Comptroller

Kevin Maguire
Assistant
Mary E Fluhr

National Advertising

Sales Representatives:
Hajar Associates Inc
East
280 Hillside Av
Needham Heights MA 02194
(617) 444-3946
521 Fifth Av
New York NY 10017
(212) 682-5844
Midwest
654 N Michigan Av
Suite 1010
Chicago IL 60611
(312) 337-8008
West, Southwest
1000 Elwell Ct
Suite 227
Palo Alto CA 94303
(415) 964-0706/(714) 540-3554

Officers of McGraw-Hill Publications Company: Gordon L. Jones, President; Group Vice Presidents: Daniel A. McMillan, James E. Boddorf; Senior Vice Presidents: Russell F. Anderson, Ralph R. Schulz, Editorial; Vice Presidents: James E. Hackett, Controller; Thomas H. King, Manufacturing; Robert L. Leyburn, Circulation; John W. Patten, Sales; Edward E. Schirmer, International.

Officers of the Corporation: Harold W. McGraw Jr., President, Chief Executive Officer and Chairman of the Board; Robert F. Landes, Senior Vice President and Secretary; Ralph J. Webb, Treasurer.

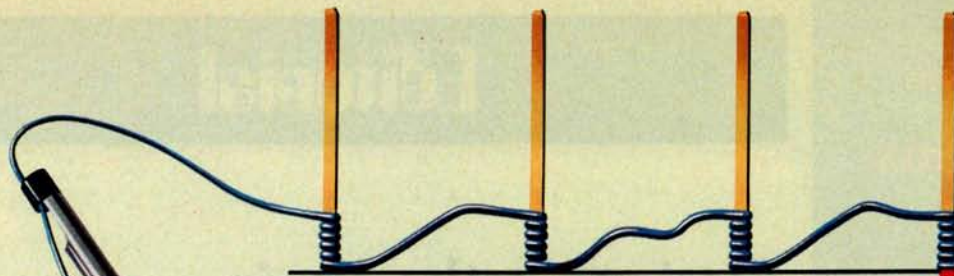

WHY CUT? WHY STRIP? WHY SLIT?
WHY NOT...

NEW

JUST WRAP™

WIRE WRAPPING TOOL

- AWG 30 Wire
- .025" Square Posts
- Daisy Chain or Point To Point
- No Stripping or Slitting Required
- ...JUST WRAP™...
- Built In Cut Off
- Easy Loading of Wire
- Available Wire Colors:
Blue, White, Red & Yellow

traditional Wire-Wrapping



JUST WRAP Wire-Wrapping



U.S.A., FOREIGN
PATENTS PENDING

JUST WRAP TOOL WITH ONE 50 FT. ROLL OF WIRE		
COLOR	PART NO.	U.S. LIST PRICE
BLUE	JW-1-B	\$ 14.95
WHITE	JW-1-W	14.95
YELLOW	JW-1-Y	14.95
RED	JW-1-R	14.95
REPLACEMENT ROLL OF WIRE 50 FT.		
BLUE	R-JW-B	\$ 2.98
WHITE	R-JW-W	2.98
YELLOW	R-JW-Y	2.98
RED	R-JW-R	2.98
JUST WRAP-UNWRAPPING TOOL		
	JUW-1	\$ 3.49



OK MACHINE & TOOL CORPORATION 3455 CONNER ST.,
BRONX, N.Y. 10475 (212) 994-6600/TELEX 125091

*MINIMUM BILLING \$ 25.00/ADD SHIPPING CHARGE \$ 2.00/NEW YORK CITY/STATE RESIDENTS ADD APPLICABLE TAX.

**Look for
Shugart drives
in personal
computer systems
made by these
companies.**

Altos Computer Systems
2378-B Walsh Avenue
Santa Clara, CA 95050

Apple Computer
10260 Bandley Dr.
Cupertino, CA 95014

Digital Microsystems Inc.
(Formerly Digital Systems)
4448 Piedmont Ave.
Oakland, CA 94611

Imsai Mfg. Corporation
14860 Wicks Blvd.
San Leandro, CA 94577

Industrial Micro Systems
633 West Katella, Suite L
Orange, CA 92667

North Star Computer
2547 9th Street
Berkeley, CA 94710

Percom Data
318 Barnes
Garland, TX 75042

Polymorphic Systems
460 Ward Dr.
Santa Barbara, CA 93111

Problem Solver Systems
20834 Lassen Street
Chatsworth, CA 91311

Processor Applications Limited
2801 E. Valley View Avenue
West Covina, CA 91792

SD Sales
3401 W. Kingsley
Garland, TX 75040

Smoke Signal Broadcasting
6304 Yucca
Hollywood, CA 90028

Technico Inc.
9130 Red Branch Road
Columbia, MD 21045

Texas Electronic Instruments
5636 Etheridge
Houston, TX 77087

Thinker Toys
1201 10th Street
Berkeley, CA 94710

Vista Computer Company
2807 Oregon Court
Torrance, CA 90503

Editorial

Designing the Logic of the System — Processor Board Design, Part 2: Will the Parts Fit on the Board?

by Carl Helmers

This month's editorial is the latest in a series begun last July describing a new homebrew 6809 personal computer system. The general backplane design was presented last month. This month we describe the processor board. Its ideal features would include:

- 6809 processor (40 pins) and buffers for external signals.
- 4 K bytes of 2708 read-only memory for systems software.
- Interrupt flags for lines IO through I7 and peripheral interface adapter (PIA) port with its interrupt request (IRQ) output tied to the fast interrupt request (FIRQ) input of the processor.
- If it fits, logic for a primary serial terminal port and connector.

In order to find out whether this is a reasonable allocation of function for the 4.5 by 9.0 inch area of 1 card in the system, we must systematically estimate the parts required for each of these segments of the logic. The series of photographs 1a through 1d show how integrated circuit sockets are used as markers in the layout of the board space requirements. Each socket has a sticky paper label attached which is marked with its assigned number. Placement of the socket on an unused prototyping board can be done to help plan the layout.

Processor Logic Requirements

The processor alone occupies a 40-pin socket, which we will call IC1 since it is the most important part of the whole computer. In addition, the discrete components of the clock crystal's parallel-resonant circuit will conservatively require the space equivalent of 1 24-pin socket. The buffers required for the data bus are a pair of DM8833 tristate, bidirectional bus buffers. These are labeled IC2 and IC3. Three SN74367 tristate drivers provide the buffering for the 16 address lines. Two sections of 1 of the address buffer chips remain unused. These circuits are labeled IC4 through IC6. Another SN74367, which will be labeled IC7, is required so that 3 of its 6 buffer sections can be used for the ENABLE, QENABLE, and RW signals of the backplane. These 7 socket positions plus the 1 24-pin dummy for the clock crystal and related discretes are shown in position for layout purposes in photo 1a.

In order to provide a uniform connection to the backplane bus, every major segment of the system will be isolated by a set of bus buffers, such as the DM8833 parts which are included in the processor section. For the remainder of the logic on the processor board which will interface to the data bus, a pair of DM8833 parts labeled IC8 and IC9 will suffice to define a local bus extension. This local bus extension will service the 2708 read-only memory, the peripheral interface adapter used for interrupt logic, and the asynchronous communications interface adapter (ACIA) used for the primary terminal of the system.

 **Shugart**

If it isn't Shugart, it isn't minifloppy.™

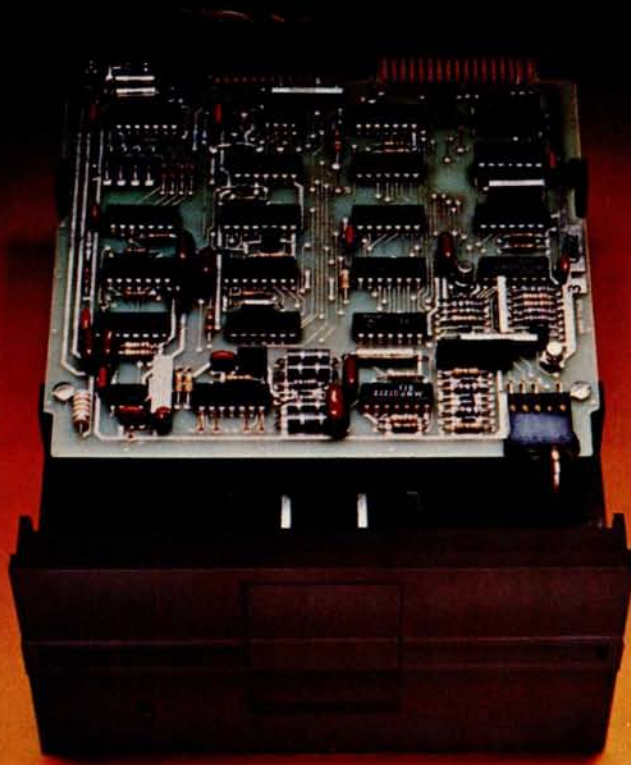

Shugart invented the minifloppy in 1976. Today there are more than 100,000 of the little drives in use. That's because users want the affordable random access data storage of the minifloppy.

Shugart packs years of proven floppy drive technology into this tiny package. Up to 110 kbytes of data storage. Fast random access of about one-half second. And high speed data transfer of 125 kbits per second. Plus sensible, maintenance-free features like write protect to prevent accidental data loss, an activity light to indicate when the drive is selected by your computer and a door interlock to protect your media from damage.

Our proprietary read/write head provides maximum data interchange margins, and it is

positioned precisely on the selected track by a patented spiral cam actuator. The DC drive motor with integral tachometer assures accurate diskette rotation and low heat dissipation. A die cast aluminum base plate provides a solid foundation for the drive.

At Shugart, technology leadership is more than a slogan, it's a commitment. Get reliability and value when you invest your money for floppy disk storage. Ask for the standard of the industry, minifloppy. If it isn't Shugart, it isn't minifloppy.

 **Shugart Associates**

435 Oakmead Parkway, Sunnyvale, California 94086

™ minifloppy is registered trademark of Shugart Associates

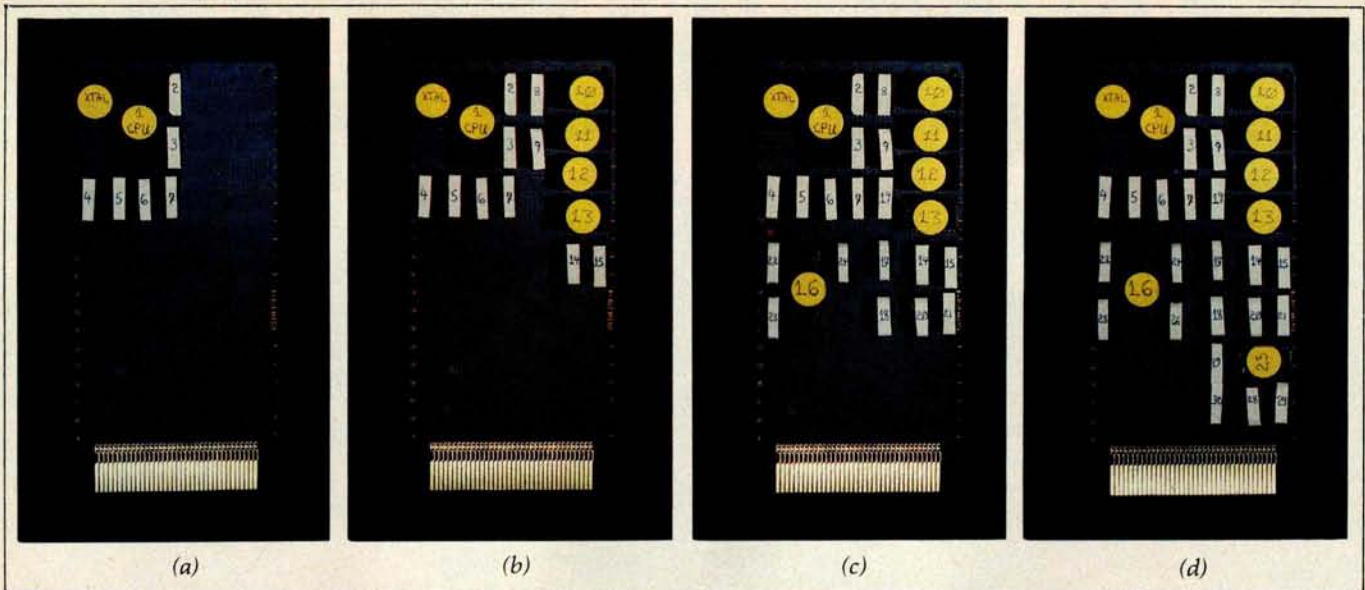

Photo 1: By using a prototyping board as a matrix, it is easy to mark wire-wrap sockets with logical identification numbers and use them as markers in creating a layout of parts for the board. This series of photographs documents the discussion of the main parts of the central processor card of the new 6809 homebrew system.

(a) The first segment of the layout is the processor itself and its crystal timing standard, data bus extension buffers, and address buffers.

(b) The second segment of the layout adds 4 read-only memory circuits and 2 socket positions needed to decode and select the individual 1024 byte segments (10, 11, 12 and 13).

(c) The third segment of the layout process adds a peripheral port (16) and logic associated with 8 interrupt flags. Miscellaneous logic at this stage includes decoding of the address of the parallel port.

(d) Finally, the logic of the central processor card is completed with the addition of a communications adapter, 25, and associated decoding and buffer circuits.

The next logic item to consider is the read-only memory bank. Four 2708 parts will be used to store up to 4 K (4096) bytes total. This memory bank will contain the resident systems software of the machine, including the fixed handlers for the 3 different classes of interrupts, the power on reset routines, etc. We will thus require 4 24-pin sockets for these integrated circuits, IC10, IC11, IC12 and IC13. In addition to the requirements of the read-only memory parts, we also require logic to decode the high-order 6 bits of an address and the read signal. The read-only memory bank must overlap addresses FFF0 to FFFF in order to provide the vector addresses for interrupts. Thus decoding logic should be provided to place this 4 K segment of memory at the upper end of the memory address space of the 6809, locations F000 to FFFF. Decoding the high-order 4 bits of addressing can be done with one half of a 7420 integrated circuit, IC14. The active-low output of this 7420, along with the RW signal and the next 2 address bits (A11 and A10) can then be decoded by a single 7442 integrated circuit, IC15, to produce a 1 of 4 selection for the active-low chip select lines of the 2708 read-only memory parts. Photo 1b shows the tentative layout of the board with the addition of the read-only memory parts and the local bus extension buffers.

The handling of interrupts in this processor will be provided by use of a single 6821 peripheral interface adapter which will be used to read a bank of 8 set-reset flip-flops found in a pair of SN74279 integrated circuits. The 6821 called IC16 will require address decoding for its location

in memory address space. This leads to the problem of allocating address space within the whole system, for the parts needed to decode an address differ depending upon what address is chosen.

So far, the only address commitment we have made is the placement of the read-only memory segment at addresses F000 to FFFF so that it overlaps the hardware requirements of interrupt vectors at FFF0 to FFFF. Let us build an address space allocation which takes into account some of the future expansion possibilities:

E000--> FFFF read-only memory (upper 4 K implemented initially).

D000--> DFFF I/O (input/output) and peripheral addresses (sparsely populated).

0000--> CFFF 52 K main memory space (lower 16 K implemented initially).

The decision to allocate 8 K bytes for read-only memory space is a conservative one which allows for the addition of up to 4 more 2708 sockets on another board. The 4096 byte address space reserved for I/O will be more than adequate. The balance of the 64 K address space is left to the main memory.

Within the I/O address space of D000 to DFFF, let us arbitrarily decide that all parallel I/O will be via peripheral interface adapters, and that these parts will be located at address D000 and continuing through D0FF. Since each 6821 requires 4 address locations for its interface, this gives a maximum of 64 such parallel ports in the

Wordsmith

Defining the New Generation in Word Processing

“

I've seen Lanier, Vydec,
Xerox, Olivetti, and Wang.
I've chosen WORDSMITH
from MICRO DIVERSIONS.

”



Congressman Charlie Rose
Chairman, Policy Group
on Information and
Computers

THE
wordsmith™
TEXT EDITOR



Yes, I'd like to learn more about Wordsmith.™ Send me your information packet.

Name _____

Company _____

Address _____

City _____ State _____ Zip _____

Micro Diversions, Inc.
8455-D Tyco Road,
Vienna, Virginia 22180
(703) 827-0888

system. At the same time, thinking ahead, let us allocate 6850 asynchronous communications adapters to address locations D100 through D1FF. This reserves 128 logical slots for potential 6850 parts — again far in excess of what will actually be implemented. The main reason for making these allocations start at even hexadecimal digit boundaries (D0 and D1 in the high-order) is to simplify interpretation of machine code and references to addresses in the hand-assembled systems software to be created later. We could just as easily have compressed the allocations into a contiguous segment of address space without holes.

After this detour into address space allocation, we can return to the problem of estimating the parts needed to decode the 6821 peripheral interface adapter used for the interrupt flag input. First, we note that the decoding of the D0xx and D1xx addresses for the 2 peripherals on this board will share common logic for 7 bits of high-order information. These 7 bits include 3 which must be logical 1 and 4 which must be logical 0. Two 8-input 7430 NAND gates, IC17 and IC18, will be used to form the high-order decoding logic, with 1 7404 hex-inverter package (IC19) used to invert the 4 bits which must be logical 0. An additional 7404 section will be required for the D0 decode to invert bit line A8. The outputs of the 2 7430 parts are active-low selections of high-order addresses D0xx and D1xx.

Returning to the 6821 part, IC16, let us allocate its detail addresses as D000 to D003. The 2 register select inputs of the circuit will get connected to the low-order

address lines, A0 and A1. We need to verify that all bits, A7 through A2, are 0 when these addresses are selected: to do this, logic of another 7404 inverter IC20 and a 7430 8-input NAND gate IC21 is required. The final result is the definition of 1 chip select input to the 6821 from the high-order address selection of D0 and a second chip select input from the low-order address selection from IC21.

With its addresses decoded, the 6821 now talks to the bus extension of the system, but we have one more item to consider: the 74279 interrupt flag chips and pull-up resistors. We will assign the numbers IC22 and IC23 to the flag registers, and assign the number IC24 to a 16-pin socket which will be used to hold 8 resistors which tie the 8 interrupt lines (I0-I7) up to +5 V when no input is present. Photo 1c shows a layout of the board after all the sockets connected with the interrupt peripheral interface adapter have been added, IC16 through IC24.

The one remaining device to consider is the addition of a 6850 asynchronous communications interface adapter which we will call IC25. This will be the terminal port through which initialization information will be sent in an American Standard Code for Information Interchange (ASCII) encoded form from the primary computer and mass storage device of the multiple processor system. In separate tests of the 6809 system, this port can be driven by a terminal, since the initialization sequences will use standard ASCII characters as opposed to a more compact binary form.

The address decoding for this port was begun in earlier considerations. We have a line decoding the D1 address of serial ports in the high-order, an output of IC18. With an asynchronous communications interface adapter, we have to decode 7 out of 8 low-order bits in order to assign the necessary 2 addresses. Using addresses D100 and D101 for this port, we need a single 7430 8-input NAND gate IC26 for the low-order selection. The inverted states of address bits A2 through A7 are shared with the decoding of the 6821 part discussed earlier, and inversion of the A1 bit can use a spare section from either the 7420 IC14 or one of the hex-inverter packages.

Also required for the serial interface is some form of a socket header for a D connector attached to a cable and level conversion integrated circuits. Thus IC27 which is an MC1488 and IC28 which is an MC1489 provide our level conversion. IC29 is a socket devoted to attachment of the cable to the D connector. By popping off the plastic cover on a wire-wrap socket, such as IC29, it is possible to insert a small (#20 gauge) stranded wire into the contacts of the socket. This wire can then be carefully soldered so that no bridges to the next pin occur, or every other pin can be assigned to this I/O function where only a subset of the 14 or 16 pins is necessary. Photo 2 illustrates this point of fabrication by way of an example.

There is one minor detail which still remains with respect to the communications interface: we need a clock which can supply a frequency of 16 times the data rate of 19,200 bps, or 307.2 kHz. It turns out that given a 5 MHz central processor clock source, we come very close to the desired data rate by simply dividing by 16 to get 312.50 kHz. The error in this frequency is 1.7%, with respect to the proper clock of 307.20. Will this work? Yes, for the

Text continued on page 14



**computer mart
of new jersey**

**the
microcomputer
people®**

**THE VITAL
INGREDIENT:
EXPERTISE**

Before you buy your new microcomputer, chances are you have a lot of questions. Important questions that could mean the difference between a working system and a wasted system. The vital ingredient is expertise. The microcomputer people at Computer Mart are expert at answering your questions and helping you put together the best system for your application. Whether it's for business, the home, or the laboratory, come see the experts at Computer Mart of New Jersey. We have the vital ingredient.

Computer Mart of New Jersey
501 Route 27
Iselin, N.J. 08830
(201) 283-0600

HOURS:
Open at 10 am,
Tuesday through Saturday

Super values in high-performance computers



WH14 Serial Printer
\$895 suggested list



WH19 Smart Video Terminal
\$995 suggested list



WH27 Dual Floppy Disk System
\$2595 suggested list



WH89 All-In-One Computer
\$2295 suggested list



WH11A 16-bit Computer
\$1895 suggested list

Heath Data Systems

You get flexible computer systems designed, built and tested to serve you in many ways — priced to pay for themselves quickly. Choose from 8-bit or 16-bit power, then add the peripherals to configure the system that best fits your needs. You get flexibility, expandability, reliability.

Hardware

The WH89 All-In-One Computer includes two Z80 microprocessors, 5¼" floppy, high-resolution CRT terminal, professional keyboard and 16K RAM (expandable to 48K) — all in one compact unit. It's a complete, balanced system ideal for word processing or any small business need.

The powerful 16-bit WH11A Computer (DEC® PDP 11/03 compatible) is designed around the DEC KD11-HA CPU and accommodates up to 64K bytes of memory. Add the WH27 Dual 8" Floppy (DEC RX01 compatible) for vast storage capacity and immediate access to programs and data. For video output, add the WH19 Smart Terminal with professional keyboard, direct cursor addressing and eight user programmable keys. The WH19 is compatible with the DEC VT52 and ANSI Escape Mode.

The WH11A System is ideal for the complex problems of business and education.

Software

The WH11A Computer runs all systems and applications software written for the DEC PDP-11/03 and that includes scores of practical programs for business, technical users and education. It also accepts the powerful DIBEX™ Operating System which is compatible with Dibol, and all Dibol-based software.

The WH27's disk operating system was developed in conjunction with DEC and supports BASIC, FORTRAN and Assembly Languages... all available from Heath Data Systems Dealers.

The disk operating system for the WH89 All-In-One Computer supports MICROSOFT™ BASIC, MICROSOFT™ FORTRAN and Assembly Languages.

Humanware

The people who build Heath Data Systems hardware stand behind it. Service is available from 55 locations throughout the U.S. and at many more locations in Canada and Europe. There's always someone nearby. Your investment is protected.

Take a closer look

Heath Data Systems are on display at your nearby Byte Shop, Computerland, Heathkit Electronic Center, Microage Dealer or other qualified computer store.

OEM discounts

They're available and they're generous. Call (616) 982-3361 for details.



data systems

Heath Data Systems, Schlumberger Products Corporation
Hilltop Road, St. Joseph, MI 49085

DEC is a registered trademark of Digital Equipment Corporation.

When you set your standards high,

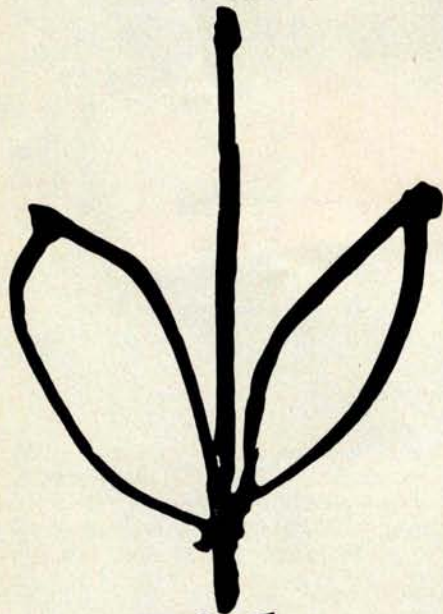
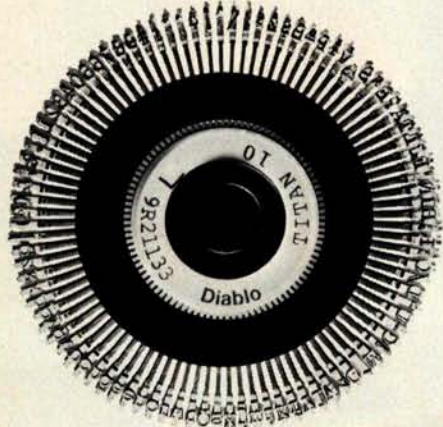

Pick A Daisy.

Diablo invented the Daisy Wheel. Which is why today, more people pick one of over 100 different Diablo Daisy Wheels when they want print quality at its finest.

So, the next time you want to set your standards high, pick our daisy and you're sure to look your best.

Diablo Systems
XEROX

Diablo® and Xerox are registered trademarks of XEROX CORPORATION.

(a)

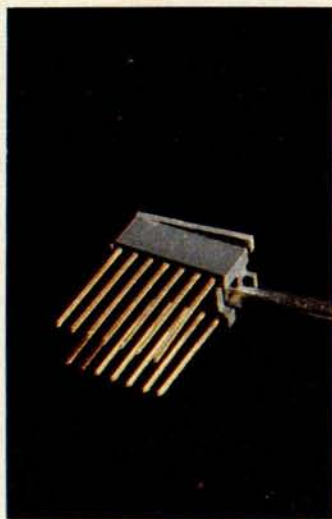

(b)

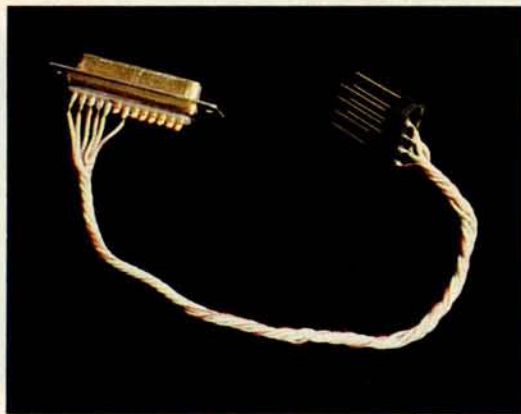

Photo 2: A good technique for interfacing wire-wrap cards with the external world is to use a socket as a header. Here is an example of how a 14-pin socket has its top cap being popped off (a). Then (b), it is possible to carefully insert small stranded wires which are firmly soldered in place and run the wires to the external device. After popping the top, it is possible to very carefully remove every other pin in order to space out the terminations and help eliminate the possibility of a solder bridge. Here we have taken a 14-pin socket and wired it with the following pin assignments for an RS-232C female D connector:

RS-232C pin	to	Socket header pin	
1	<----->	1	chassis ground
2	<----->	3	output
3	<----->	5	input
4	<----->	7	request to send
5	<----->	8	clear to send
7	<----->	10	signal ground

id	pins	type	comments
IC1	40	6809	microprocessor
IC2	16	DM8833	tristate bidirectional buffers D0-D3
IC3	16	DM8833	tristate bidirectional buffers D4-D7
IC4	16	74367	tristate buffers A0-A6
IC5	16	74367	tristate buffers A7-A11
IC6	16	74367	tristate buffers A12-A15
IC7	16	74367	tristate buffers ENABLE, QENABLE, RW
IC8	16	DM8833	tristate bidirectional buffers D0-D3 local bus extension
IC9	16	DM8833	tristate bidirectional buffers D4-D7 local bus extension
IC10	24	2708	read-only memory, F000-F3FF
IC11	24	2708	read-only memory, F400-F7FF
IC12	24	2708	read-only memory, F800-FBFF
IC13	24	2708	read-only memory, FC00-FFFF
IC14	14	7420	
IC15	16	7442	
IC16	40	6821	peripheral interface adapter, D000-D003 interrupt port
IC17	14	7430	high-order decode select for IC16
IC18	14	7430	high-order decode select for IC25
IC19	14	7404	
IC20	14	7404	
IC21	14	7430	low-order decode fo IC16
IC22	16	74279	interrupt flag latch, I0-I3
IC23	16	74279	interrupt flag latch, I4-I7
IC24	16	5 K ohm	resistors for interrupt line pullups
IC25	24	6850	asynchronous communications adapter, D100-D101
IC26	14	7430	low-order decode for IC25
IC27	14	MC1488	TTL to RS-232C line drivers
IC28	14	MC1489	RS-232C to TTL line receivers
IC29	14	---	14 pin socket for RS-232C cable termination
IC30	14	7473	divide by 4 for communications clock rate

Table 1: List of integrated circuits for new 6809.

**Tinker, Tailor, Soldier, Sailor . . .
Doctor, Lawyer . . . the Chieftain's here.**

No matter whether you're a serious hobbyist or a serious businessman, the Chieftain 6800 microcomputer with capabilities that surpass the Z-80 is made for you.

Smoke Signal's quality-packed Chieftain I features two 5.25-inch mini-floppy drives and Chieftain II features two 8-inch floppy drives.

Both microcomputers provide 32K static memory, two serial I/O ports, a 2 MHz processor board, a 2K RAM monitor, a nine-slot motherboard with built-in baud rate generator and gold connectors for high reliability. The Chieftain's stylish leather-grained cabinet houses the above with its own cooling fan and regulated power supply.



Every Chieftain is complete with system software and is totally burned-in as well as tested to further insure high reliability.

And it's expandable to 64K memory with up to 2 megabytes floppy disk storage.

So see your nearest Smoke Signal dealer, he'll be glad to show you how to get your wampum's worth. Systems start at \$2,595.

- Send information on your Chieftain microcomputer
- Send name of nearest dealer

Name _____

Address _____

Company _____

City _____

State/Zip _____



**SMOKE SIGNAL
BROADCASTING**

31336 Via Colinas, Westlake Village,
California 91361. (213) 889-9340

Dealer inquiries invited.



Hail to the Chieftain

Smoke Signal Broadcasting, 31336 Via Colinas, Westlake Village, CA 91361, (213) 889-9340

Improve TRS-80 performance with new DOS+

Enjoy the wizardry of your TRS-80 to its fullest: maximize and expand all of its magical capabilities with the new DOS+. Just look at the capabilities you can evoke.

Modifications, corrections, and enhancements to Radio Shack's TRS DOS 2.1.

- A Basic **REFERENCE** command for variables and numbers.
- A super-fast machine language **RENUM** program executable under BASIC.
- A built in keyboard-debounce routine.
- A print screen option under DOS or BASIC to your line printer. Simply press JKL keys.
- New copy commands for backup, allows you to copy from drive to drive keeping the same filespec.
- Execution of DOS commands while in BASIC.
- New BASIC scrolling and invocation commands and more.
- Apparat's own **SUPERZAP**, a Hex dump utility to examine or modify disk or memory locations.
- Modified **EDITOR ASSEMBLER** with Disk I/O and new cross reference feature.
- A super-fast machine language **DISASSEMBLER** program.
- A **LOAD MODULE** for transferring machine tapes to disk.
- Faster disk access.
- **Level I ROM** relocated in Level II RAM.
- The capability of storing and retrieving Level I programs on Disk.
- An improved **DISK DUMP** program.
- A **DIRCHECK** program to test a directory & list/display the contents in alphabetical order with extensions.

You don't have to pull a rabbit out of a hat... Send \$99 for the Apparat/MTI New DOS+ (on diskette). See all the magic unfold before your eyes.

INTRODUCTORY SPECIAL

NEW DOS+ and the very **Best of Apparat's** disk utility programs **\$99.00** (a \$250.00 value). 40-Track Version **\$110.00**.

To order your diskette of tricks, write or call one of our dealers.

MTI MICROCOMPUTER
TECHNOLOGY
INCORPORATED
2080 South Grand Ave.
Santa Ana, CA 92705
(714) 979-9923

A 6000 E. Evans Ave., Bldg. 2
Denver, CO 80222
(303) 758-7275
Apparat, Inc.

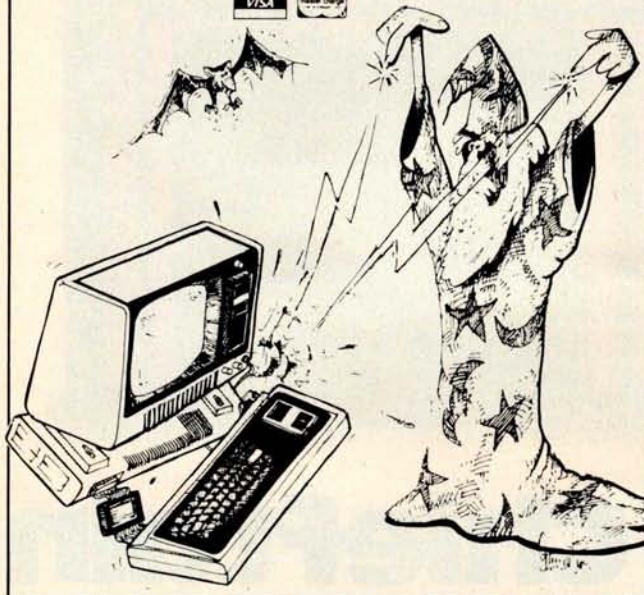

Text continued from page 10:

total time of 1 character, the error in the last bit sent is what counts. A character is a sequence of 11 bit times; 1 bit has a width of 1/11th or 9.1% of the total time involved. The worst case of the last stop bit in the 11 bit sequence (start bit, 8 data bits, 2 stop bits) will have the full timing error of 1.7% of the total period for 1 character. We could probably get away with as much as a 5% to 6% error in the frequency of the data rate clocks.

Thus by providing a 2-bit divider in the form of a 7473 circuit IC30, we get the clock needed for the communications circuit from the crystal controlled 1.25 MHz ENABLE output of the processor. It turns out that the serendipity of the 5 MHz junk box crystals really worked in planning this system. If it is necessary to use a 4 MHz crystal for the system because the 6809 will not run 25% faster than its specification then use of a divisor of 13 instead of 16 produces a data rate of 307.7 kHz which is only 0.2% off the desired 307.2 kHz rate. In this case of a 4 MHz source, a 74193 would be used instead of a 7473 for IC30, and input to the 74193 would be taken from the tank circuit through a relatively high-impedance buffer.

This completes the preliminary consideration of the central processor card design. As can be seen in photo 1d, the 30 integrated circuits sockets required for this central processor design fit the space available on the prototyping card with room to spare. Table 1 summarizes the integrated circuit and socket list as it stands now. This verbal discussion ahead of drawing a diagram of the circuit is an experiment. In past designs, I have jumped right in to the drawing of a logic diagram. The actual circuit diagram has not been drawn as of this writing (June 18 1979), and 1 or 2 integrated circuits may be necessary to provide an additional random logic gate or inverter beyond those anticipated in this discussion.

In the next installment of this series on building a homebrew general purpose computer for use as a communications controller, we shall start with a verification of these design considerations as an actual diagram, then proceed to discuss construction and testing of this first card in the system. As emphasized in the earlier comments in this series, the timing of the publication of these notes depends upon the amount of spare time I have available to devote to this activity. The intent of this series is to show our readers how simple it is to assemble homebrew systems out of standard parts, using design information which is available in various publications put out by semiconductor manufacturers. ■

Articles Policy

BYTE is continually seeking quality manuscripts written by individuals who are applying personal computer systems, designing such systems, or who have knowledge which will prove useful to our readers. For a more formal description of procedures and requirements, potential authors should send a large (9 by 12 inch, 30.5 by 22.8 cm), self-addressed envelope, with 28 cents US postage affixed, to BYTE Author's Guide, 70 Main St, Peterborough NH 03458.

Articles which are accepted are purchased with a rate of up to \$50 per magazine page, based on technical quality and suitability for BYTE's readership. Each month, the authors of the two leading articles in the reader poll (BYTE's Ongoing Monitor Box or "BOMB") are presented with bonus checks of \$100 and \$50. Unsolicited materials should be accompanied by full name and address, as well as return postage.

SSM "BLUE BOARDS"

The Standard of Value

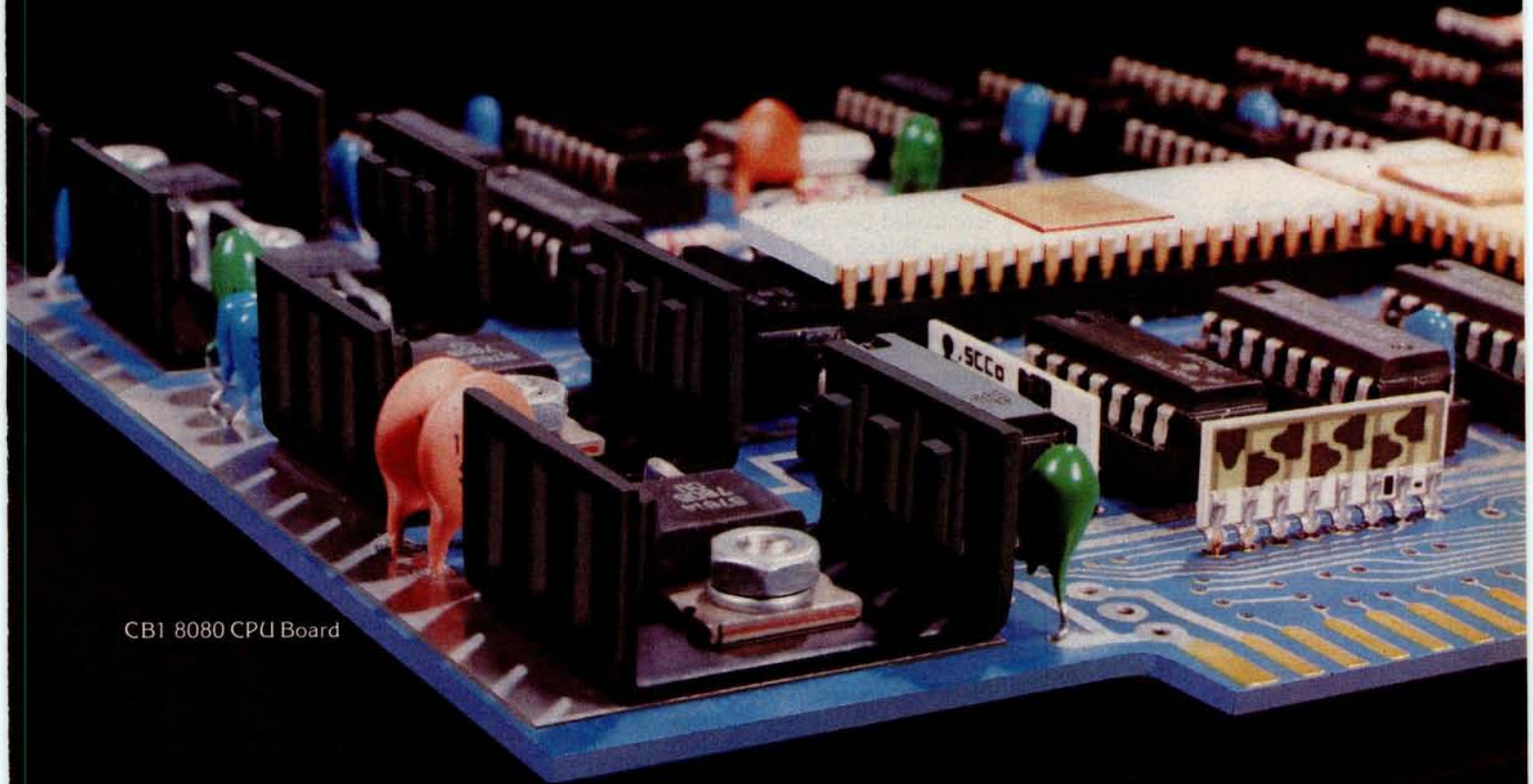

CB1 8080 CPU Board

If you're looking for outstanding value in S-100 boards you can't afford to overlook the "Blue Boards" from SSM. The best combination of design, quality and price available anywhere. Innovative designs that feature versatility and reliable performance. Quality backed by a strong warranty. And prices that won't let you down.

But value goes beyond the boards themselves. It's reflected in the company that stands behind them. And SSM has been known for unparalleled customer service since the beginning of the personal computing industry.

With one of the broadest product lines in the S-100 marketplace, it's likely that SSM has the board you need. So, if you're looking for value, ask for the "Blue Boards." They're available at over 150 computer stores nationwide and abroad.

Available assembled or as kits.



Our product line includes CPU, Video, I/O, RAM, EPROM, EPROM Programmer, Music, Prototyping, Terminator, Extender and Mother boards.

Send for our free brochure and find out why SSM has become the favorite of discerning Hobbyists and OEMs.



2116 Walsh Avenue
Santa Clara, CA 95050 (408) 246-2707

We used to be Solid State Music. We still make the blue boards.

New CRT SENSATION!

You have been reading about our astounding Pascal MICROENGINE™ CPU that executes Pascal 13x faster than an LSI-11 and 3x faster than a PDP11-34. Your orders show it! That is our Model X-90.

Now meet another sensation in our X-pert Systems™ configuration. CRT Model X-920.

*Trademark Western Digital Corporation

DISPLAY/EDIT TERMINAL Model X-920

\$968*

\$856* (Without 18 function keys)



STANDARD FEATURES (partial list)

- Microprocessor controlled
- Serial RS232C and 20 ma current loop
- 10 baud rates—75 to 19,200
- 24 lines x 80 characters
- 96 ASCII displayable characters
- Upper and lower case
- 12 x 10 character resolution
- Dual intensity display
- Clear full intensity data only
- Programmable reverse video
- Programmable underline
- 105 keys with alpha lock
- 14 key numeric pad with decimal
- 16 special function keys
- 8 edit function keys
- 2 block transmission keys
- Self test mode
- Protect mode
- Block mode
- 80 storable tabbing
- Insert/delete character and line
- Scrolling
- Addressable cursor
- A host of other features, including cursor controls and remote commands such as clear to nulls, spaces, end of line, end of screen, set hi,lo,zero intensity; set blink; etc.
- **Optional** screen print & 2nd page memory

For our system or for yours, in commercial, technical, educational or personal applications, the Computex X-920 is unmatched in its price class.

Coming soon is our Model X-8000. This high performance 16-bit CPU, using the Z-8000, addresses 8M bytes of memory directly!

All features of the Hazeltine 1400 and ADM-3A

- Plus:** 128 ASCII characters ...
 7 x 10 matrix ... Reverse video ... Print key ...
 Shiftlock ... Transparent mode ... Backspace ...
 Tabbing ... Integrated numeric pad.



\$799*

List price \$956*

PERKIN-ELMER (Model 550)

Off the shelf delivery now on the Model X-920 and P-E Model 550. Same day shipping on all orders with certified cash payment. Specify shipping and add 40 lb cost. Any difference refunded. A \$25 connecting cable free with every CRT ordered before December 1.

Customer satisfaction is guaranteed. Full refund with the return of any product within 10 days. Service contracts available. Systems catalog \$1. Pascal MICROENGINE™ owners manual \$19.95 (postpaid).

*LIMITED TIME cash price. 10% down guarantees priority. IL residents add 5% sales tax. Master Charge and VISA accepted.

(312) 684-3183

COMPUTEX
 "The Computer Experts"
 5710 Drexel Avenue
 Chicago, IL 60637

Letters

ULTRASONIC TRANSDUCERS LOCATED

Just a short note to ask for a helping hand and to let you know that your articles in BYTE are read and enjoyed.

In your article "Building a Computer Controlled Security System for Your Home" (March 1979 BYTE, page 150) you showed a circuit for generation and detection of ultrasonic signals. Would you be so kind as to note a company or two that I could contact for transducers? I have an application for ultrasonics and need a little help in knowing where to write.

Thank you for your help, and again I enjoy your articles.

Tom Yocom, WA1RTD
 21 Bayberry Rd
 Acton MA 01720

Author Ciarcia Replies:

The particular transducers used in the March article are from MASSA in Hingham MA, I obtained them through Bullet Electronics, POB 401244E Garland, TX 75040, (214) 278-3553. I suggest calling them to determine price and availability. Since I usually purchase components in large quantities long before I actually need them for an article, I hesitate to quote a price and a definite source. The MASSA units had an output frequency of 23 kHz.

LONG DISTANCE COMMUNICATION

I saw your article in the May issue of BYTE ("Communicate on a Light Beam," page 32) and became very interested. I have an application which requires sending data up to a kilometer at speeds from 2000 to 9600 characters per second (cps). Your descriptions of the fiber optic cable and the light-emitting diode (LED) transmission circuits seem to be ideal, if they are cost effective.

Could you give more details of the distances which the circuits can drive and the addresses of the suppliers of the fiber optic components?

R H Fields
 1 Wytheigate
 Riverside Rd
 Staines, Middlesex
 United Kingdom

Author Ciarcia Replies:

Realize, of course, that the circuits presented, while possibly usable in commercial applications, are presented more to introduce the reader to the concept of fiber optic communications than solve any particular application problem.

Their usability in a 1 kilometer data link depends upon more than just the electronic parameters of the circuit. The laser probably can drive such a length, but cable losses and mechanical/optical connections are going to be an important factor in any success.

When you speak of 9600 cps that is approximately 100 k bits per second (bps) and is a reasonable transmission rate. However, response time of the receiver electronics is going to be much more critical than a 10 k bit rate. Given the length of cable as 1 kilometer, I would caution you that a certain intensity must be maintained at the output to achieve this response.

Rather than try to reinvent the wheel or try to second-guess the technical people who really know the field, I think you would be better off purchasing a commercial system. The following is a list of American companies which deal in fiber optics. I am sure they will have a cost-effective solution for you:

- Corning Glass Works
 Telecommunications Dept
 Corning, NY 14830
 (607) 974-8812
- Dupont Co
 Plastic Products and Resins Dept
 Wilmington, DE 19898
 (302) 774-7850
- Fiberoptic Cable Corp
 POB 1492
 Framingham, MA 01701
 (617) 875-5530
- Galileo Electro-Optics Corp
 Galileo Park
 Sturbridge, MA 01618
 (617) 347-9191
- General Cable Corp
 500 W Putnam Ave
 Greenwich, CT 06830
 (203) 661-0100
- ITT
 Electro-Optical Products Div
 Roanoke, VA 24019
 (703) 563-0371
- Quartz Products Corp
 688 Somerset St
 Plainfield, NJ 07061
 (201) 757-4545
- Times Fiber Communications Inc
 358 Hall Ave
 Wallingford CT 06492
 (203) 265-2361
- Valtec Corp
 Electro Fiberoptics Div
 West Boylston, MA 01583
 (617) 835-6083

For further descriptive information on the use of fiber optics I suggest you refer to the January 5, 1978 issue of EDN magazine and an article titled "Designer's Guide to Fiber Optics."

Text continued on page 18

North Star Horizon— COMPUTER WITH CLASS

The North Star Horizon computer can be found everywhere computers are used: business, engineering, home — even the classroom. Low cost, performance, reliability and software availability are the obvious reasons for Horizon's popularity. But, when a college bookstore orders our BASIC manuals, we know we have done the job from A to Z.

Don't take our word for it. Read what these instructors have to say about the North Star Horizon:

"We bought a Horizon not only for its reliability record, but also because the North Star diskette format is the industry standard for software exchange. The Horizon is the first computer we have bought that came on-line as soon as we plugged it in, and it has been running ever since!"

— Melvin Davidson, Western Washington University, Bellingham, Washington

"After I gave a 1/2 hour demonstration of the Horizon to our students, the sign-ups for next term's class in BASIC jumped from 18 to 72."

— Harold Nay, Pleasant Hill HS, Pleasant Hill, California

"With our Horizon we brought 130 kids from knowing nothing about computers to the point of writing their own Pascal programs. I also use it to keep track of over 900 student files, including a weekly updated report card and attendance figures."

— Armando Picciotto, Kennedy HS, Richmond, California

"The Horizon is the best computer I could find for my class. It has an almost unlimited amount of software to choose from. And the dual diskette drives mean that we don't have to waste valuable classroom time loading programs, as with computers using cassette drives."

— Gary Montante, Ygnacio Valley HS, Walnut Creek, Calif.

See the Horizon at your local North Star dealer.

Circle 285 on inquiry card.

NorthStar 

North Star Computers
1440 Fourth Street
Berkeley, Ca 94710
(415) 527-6950 TWX/TELEX 910-366-7001



Text continued:

Phone Company Maps...

In reference to your article on map generation ("Computer Generated Maps," May 1979 BYTE, page 10) the telephone industry has gridded the US with a system of vertical and horizontal coordinators ("V & H's"). A discrete set of four digit "V & H's" for virtually every city, town and village is listed Federal Communications Commission tariffs.

"V & H" coordinates offer a quick and simple way to plot maps of American locations. For example, the program listing, at right, written for an

Apple II, uses "V & H" coordinates for 72 border towns to sketch an outline map of the US.

Joseph P Garber
36 Sutton Place S
New York NY 10022

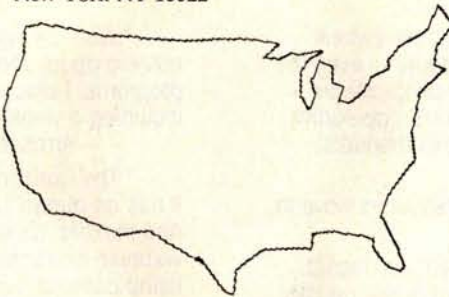

```

400 REM : BEGIN MAP ROUTINE
401 HCOLR = HCOLOR = 3
403 DEF FN VFXA) = INT ((A - 3
300) / 35): DEF FN HF(A) =
INT ((A - 9250) / - 35)
405 READ OO,ZZ
406 HCOLOR = 7
410 FOR I = 1 TO 72
420 READ XX,PP
430 HPLDT FN HF(ZZ), FN VF(OO) TO
FN HF(PP), FN VF(XX)
435 OO = XX:ZZ = PP
440 NEXT I
450 DATA 3303,1577,3884,1645,43
19,2068,4680,4113
460 DATA 4740,5648,5055,2378,539
8,2448,5648,5663
470 DATA 6704,2880,5367,2813,53
88,2085,5061,3150
480 DATA 5027,2441,5437,3490,56
95,3303,5017,2335
490 DATA 5788,5583,5372,3753,51
08,3561,4886,5473
500 DATA 5479,5473,5113,4037,52
91,4237,5362,4550
510 DATA 5006,4546,5074,4871,51
06,5151,5475,5613
520 DATA 5861,7642,5036,3375,6
81,9238,6666,91
530 DATA 7432,9158,7582,9113,79
05,9087,8266,8942
540 DATA 8492,8719,9140,8093,9
227,7920,9482,76
13
550 DATA 2385,7171,9466,6182,92
32,3655,4605,4370
560 DATA 9406,4483,9882,3766,9
8,65,3605,4437,57
00
570 DATA 9096,3466,8832,3276,85
64,2425,3296,2481
580 DATA 8097,5097,8091,1818,80
06,1271,8247,1208
590 DATA 8447,8040,8439,0543,83
51,0527,7883,0946
600 DATA 7565,1280,7047,1264,66
21,1119,6339,1012
610 DATA 5815,1236,5073,1348,47
39,1178,4424,1017
620 DATA 4422,1249,4300,1302,41
21,1334,3577,1131
630 DATA 3303,1577

```

64KB MICROPROCESSOR MEMORIES

- S-100 - \$750.00
- LSI - \$750.00
- SBC 80/10 - \$750.00
- 6800 - \$750.00



CI-S100 64K x 8

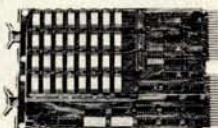

CI-1103 32K x 16

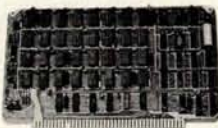

CI-6800 64K x 8



CI-8080 64K x 8

CI-S100 — 64K x 8 on a single board. Plugs directly into the IMSAI, MITS, TDL, SOL and most other S-100 Bus computers. No wait states even with Z80 at 4Mhz. Addressable in 4K increments. Power requirement 6 watts. Price \$750.00.

CI-1103 — 8K words to 32K words in a single option slot. Plugs directly into LSI 11, LSI 11/2, H11 & PDP 1103. Addressable in 2K increments up to 128K. 8K x 16 \$390.00. 32K x 16 \$750.00 qty. one.

CI-6800 — 16KB to 64KB on a single board. Plugs directly into Motorola's EXORcisor and compatible with the evaluation modules. Addressable in 4K increments up to 64K. 16KB \$390.00. 64KB \$750.00.

CI-8080 — 16KB to 64KB on single board. Plugs directly into Intel's MDS 800 and SBC 80/10. Addressable in 4K increments up to 64K. 16KB \$390.00. 64KB \$750.00

Tested and burned-in. Full year warranty.



Chrislin Industries, Inc.

Computer Products Division

31352 Via Colinas • Westlake Village, CA 91361 • 213-991-2254

5 BYTE CONVERSION

The "5 Byte Hexadecimal to ASCII Converter" described by Ashwin L Doshi (June 1979 BYTE, page 208) will work on the 8080, but not on the 8085 or Z80. As Doshi points out, the routine depends on the carry and the auxiliary carry being reset at the start of the routine. In practice, the conversion routine is preceded by an instruction ANI 0FH to mask off the upper 4 bits so that only the remaining 4 bits of the byte to be converted are passed to the routine. In both the 8085 and the Z80, however, the logical AND instruction sets this flag. The well-known 6-byte routine functions properly on both the 8085 and Z80.

Robert G Durnal
POB 68
Junior WV 26275

INFORMATION WANTED

I have a Heath microcomputer that I am using for market research. I am trying to locate a company where I can buy the weekly closing prices of the New York Stock Exchange and the Commodity exchanges on audio cassette.

I hope one of your readers can help me. Thank you.

Earl O Williams
280 Henderson St Apt 7J
Jersey City NJ 07302

MICROTEK

OUTPERFORMS THEM ALL!



V CHECK THESE FEATURES...

- 80 or 120 columns (software selectable)
- Double width printing
- Plain paper, pin feed
- 125 CPS, 70 lines per minute
- 9 x 7 dot matrix
- Vertical format unit
- 96-character ASCII (upper and lower case)
- Adjustable forms width
- Parallel, serial (RS-232), and IEEE-488 interfaces available

How can we make such a claim when the Microtek Printer looks exactly like the ones advertised by other manufacturers? We're glad you asked. We'd like to clear up the confusion.

A large Japanese hardware manufacturer recently introduced a good, low cost print mechanism into the U.S. market. They also announced a fully packaged printer using this mechanism to the OEM market. Then another company started to sell this printer to hobby, home and small business computer users.

We took a long hard look at this printer and liked what we saw. The mechanism was reliable. The case was beautifully designed. What we didn't care for was the 5 x 7 dot matrix format. We also believed some form of condensed character set and a few other alterations in software would be significant improvements.

So we bought the mechanism and the case. But we designed our own logic board and wrote new software. The Microtek Printer. Looks the same as the others but really isn't. It's better. It's one giant step ahead of its competition.

V CHECK THIS CHART...

FEATURES	Microtek MT-80	Anadex DP-8000	Centronics 779-2 (Radio Shack 26-1152)	Centronics 730-1 (Radio Shack 26-1154)	Super Brain LP-80
Dot matrix format	9x7	9x7	5x7	7x7	5x7
Characters per line	80/120	80	80/132	80	80
96 char ASCII (upper + lower case)	Yes	Yes	No	Yes	Yes
Throughput rate	70 lpm	84 lpm	21 lpm	21 lpm	63 lpm
VFU	Standard	Standard	N/A	N/A	Standard
Bi-directional printing?	Yes	Yes	No	No	Yes
Built-in self test?	Yes	No	No	No	Yes
Unit price	\$750*	\$995	\$1,350-1,559	\$970-995	\$985

*Parallel interface

Comparison data from manufacturer's current (August '79) literature.

NOW CHECK THIS COUPON...

Send me more information
 MICROTEK, Inc., 7844 Convoy Court, San Diego, CA 92111
 (714) 278-0633

Name _____

Address _____

City _____ State _____ Zip _____

Phone _____ Dealer inquiries invited!

HOW TO MAKE



YOUR FIRST MILLION

New 1.2 megabyte quad-density disk. \$1545.

Now you can afford to put a million bytes of memory in your S-100 system.

Introducing DISCUS 2+2™ full-size quad-density floppy disk system by Morrow. DISCUS 2+2™ gives you 1.2 megabytes per diskette (600K bytes of double-density data per side). And it's all addressable as easily as main memory with the system's exclusive BASIC-V™ virtual disk BASIC software.

Best of all, DISCUS 2+2™ comes complete, assembled, and ready to run for just \$1545. Included in the system price are an S-100 controller, factory-mounted full-size disk drive, a complete library of pre-interfaced software, even cables and connectors.

But you don't have to get your first million in one big megabyte. Morrow's DISCUS/2D™ single-side double-density floppy disk system gives you 600K per full-size diskette for just \$1149, complete and assembled. And when you want to expand to a full megabyte, just plug in a second drive... both the hardware and software are expandable.

And if economy is a real concern, you can still get started on your million with Morrow's DISCUS I™ 250K single-density disc system. It's delivered complete and assembled for just \$995... and will accept up to 3 more drives.

All three Morrow disk systems meet the Proposed IEEE S-100 standard and are compatible with 2MHz, 4 MHz and 5 MHz S-100 systems. A dual-drive cabinet is available as an option with any density you choose.

Why set your goals low and slow with a mini-floppy system? Get started on your first million with a DISCUS™ full-size system by Morrow. See your local computer shop. Or write Thinker Toys™ 5221 Central, Richmond, California 94804. Or call (415) 524-2101, weekdays 10-5 (Pacific Time).



Morrow Designs

Thinker Toys™

Circle 255 on inquiry card.

S C U S
2D

Tracing Your Own Roots

Stan W Merrill
Computer Resource Associates
914 E 61st St
Chicago IL 60637

Tracing your own roots satisfies an intangible craving that many people have — a craving to understand your place in a heritage that was developed by people who are perhaps more like yourself (at least genetically) than any other people on Earth. The process involves untangling puzzles that tax the most intelligent imagination. Relationships must be deciphered from other people's memories and from bits and pieces of written records that form a fragile and sometimes inadequate link between you and your ancestors. It is a natural application for a microcomputer.

Doing Genealogy

How does a person go about tracing his or her roots? There are several steps that make the process simpler. Some of these steps are enumerated in the following section.

Step 1. The best place to start searching for your family is, of course, at home. You should jot down on paper or key into the computer all the things that you know (or think you know) about your ancestry, then look for family records, such as Bibles and cor-

About the Author

Stan W Merrill is a partner in Computer Resource Associates, a Chicago based consulting firm which he recently helped found. Between times, he is writing his doctoral dissertation in sociology at the University of Chicago. Genealogy is a traditional activity in his family, and some of his lines have been traced back several centuries.

respondence. Frequently these will contain useful leads that make it easier to document facts later on. Next, contact family members: parents, siblings, the proverbial great-great-aunt, and anyone else who might possess a piece of family information. It is useful to quiz these relatives about parents, events, dates, and places, beginning with those people who are closest to you in time, and working backward.

If other family members are interested, it may be possible to establish a family organization that will hold occasional family reunions and share the fun and work of searching out ancestors. Such an organization already exists in many families.

It is not unusual for such contact with family members to plunge the new genealogist into the first meaningful contacts with some relatives. Such contact draws people into warmer and closer relationship that is, in itself, a substantial reward for the effort invested in genealogy.

Step 2. The memories collected from family members cannot usually provide adequate proof of the events recalled, since the human capacity to remember information accurately is imperfect. Memories merely provide hints for where to look for birth, marriage, and death certificates (known as *vital records*), or for entries in church and civil record books that will document the information. These documents provide official information about particular ancestors, and

also give possible clues about other ancestors in the chain.

Several sources exist for finding these documents. Often ancestors will have resided in a single locality for several generations. A letter to the clerk of the political jurisdiction (county, province, etc) where they lived, or to the parish cleric in countries where churches kept the vital records, will often elicit copies of desirable information. These places can be visited in person as well.

A number of institutions collect and preserve genealogical records on a national or international basis, and make these records available to the public. The institution with what is undoubtedly the most complete collection is:

The Genealogical Society
Church of Jesus Christ
of Latter Day Saints
50 E North Temple
Salt Lake City UT 84102

You do not have to belong to the Church of Latter Day Saints in order to use their genealogical data sources. While the main library is in Utah, branch libraries are scattered throughout the United States and much of the world. The telephone number of a unit of the church can be found in most telephone directories, and a phone call will produce information about the location of the nearest branch library.

Other excellent sources of genealogical data include:

"Our reputation rests on digits, decimal points, and details. We wouldn't trust them to anything less than Scotch® Brand Data Cartridges."

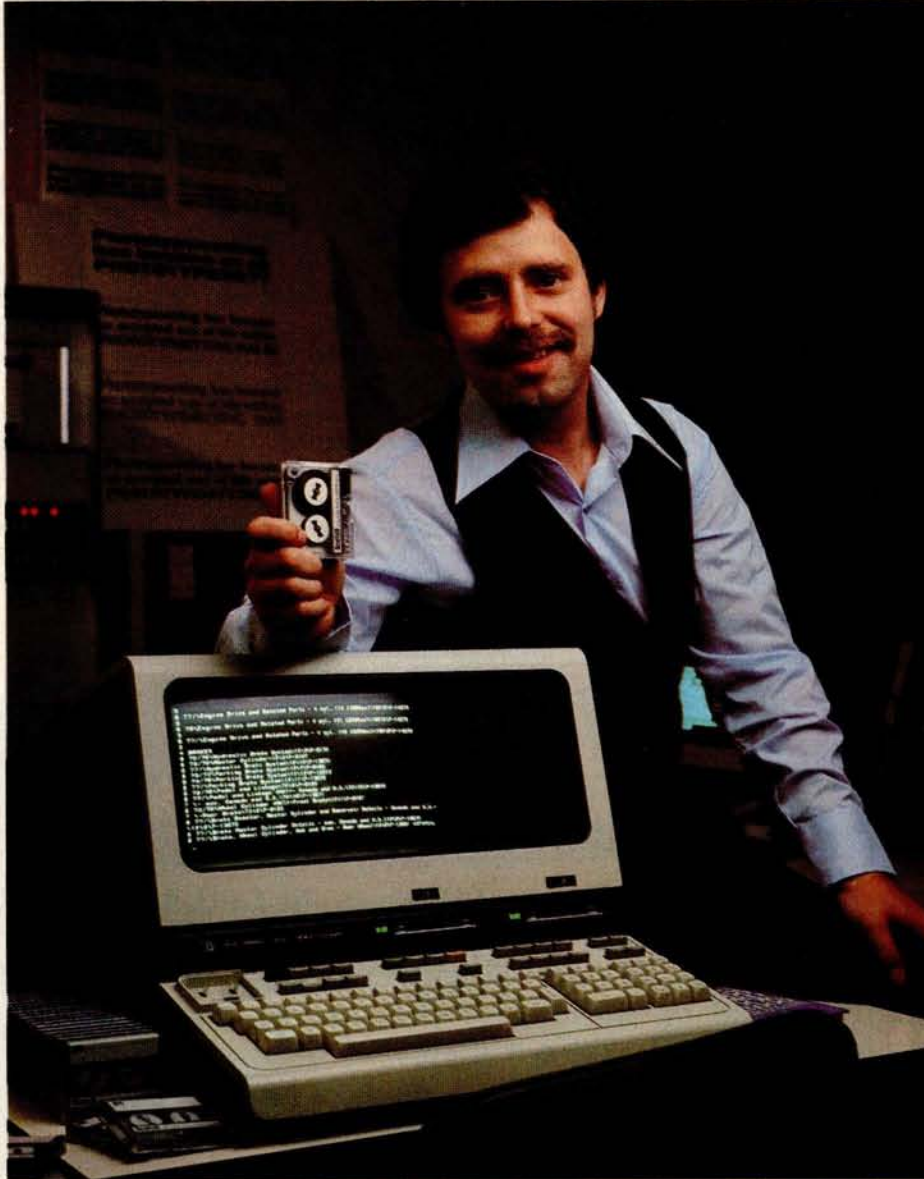

Bill Birkett, Vice President,
Trade Graphics, Inc.,
Livonia, Michigan

The unique design of a data cartridge provides great reliability, high storage capacity and long tape life. And where could you possibly get better data cartridges than Scotch Brand, made by 3M, the people who invented the data cartridge system itself?

3M controls every step in manufacturing. Top quality magnetic tape and precision components are part of every Scotch Data Cartridge. Over twenty-five years of service to the computer industry assure you of the utmost reliability.

Scotch Data Cartridges are available in miniature DC 100A, the standard-size DC 300A and now, an extra-length DC 300XL with 50% more storage capacity. They are compatible with most cartridge systems including Hewlett-Packard, IBM, NCR, Tektronix and TI.

To find out where you can find Scotch Data Cartridges or virtually any other data recording medium, call toll-free: 800-328-1300. (In Minnesota, call collect: 612-736-9625.) Ask for the Data Recording Products Division.

**If it's worth remembering,
it's worth Scotch
Data Recording Products.**



3M

Central Reference Div
National Archives
Washington DC 20408

Library of Congress
Washington DC 20540

Newberry Library
60 W Walton St
Chicago IL 60610

New York Public Library
5th Av and 42nd St
New York NY 10018

This list is not exhaustive, but writing or visiting one of these places will help anybody get started. It is also useful to talk to a reference librarian at a local library. They will often know of nearby sources of genealogical information.

Step 3. It is fairly easy and pleasant for most people to trace back their ancestry 3 or 4 generations. But when a line migrates across an ocean, or when records become less complete (as they invariably do when going further back in time), ingenuity comes into play. Passenger lists, cen-

suses, and tax lists may provide clues to the identity of ancestors who cannot be located in vital records. A knowledge of history is acquired while searching for clues about mass movements in which ancestors may have participated.

This is where the computer comes in. To know what is missing becomes increasingly difficult as the number of ancestors for whom you have information increases. It scarcely needs to be said that computerizing the records makes it much simpler to keep track of the data.

Still more helpful is the use of the computer to solve puzzles. Suppose, for instance, that you cannot find any more family members in a certain line, but you notice from the output data that a related family line has moved to a new locality at about the same time. You have been given a hint that the first family line may also have migrated there, and you can begin to search for information in the records of that particular place.

Using the Program

You need not be a genealogical

expert to utilize the program that is listed here. Item 1 on the program's menu (table 1) automatically prompts the user for the most important information about each ancestor. (See listing 1.) This information includes birth date and place, parentage, marriages, and date and place of death. The program asks for the sources of information too, so that the inevitable need to check entries will be easier.

To list the information for any or all of the names that have been entered into the file, you can use item 2 on the menu. An example of a listing for one individual is shown in listing 2. A person can be located by name or by number. Because it is possible for there to be more than one individual in the file with the same name, you should make certain that the person listed is the correct one. The program as now written will not search beyond the first occurrence of a name unless the *all* option is selected. When *all* is typed in response to the prompt, the subroutine will read sequentially through all of the records in the file.

WE HAVE IT

What is IT? The New Pascal Microengine.

IT features the new Western Digital 16 Bit Pascal Microengine CPU, 64K RAM, (2) RS232 ports, (2) parallel ports & (2) REMEX RFD 4000 double sided double density disk drives. IT will directly execute Pascal generated P-Code (the only CPU on the market designed to directly execute a high level language), & IT will run compiled BASIC. Wait, that's not all — IT normally sells for \$4,495, but you can have IT for \$4,195. Dealer prices are much lower. Plus we have peripherals and software galore. Call us about IT at (803) 756-6000.

**THE PASCAL
MICROENGINE
FROM THE COMPANY
THAT GIVES YOU
TOMORROW'S INVENTIONS
TODAY**

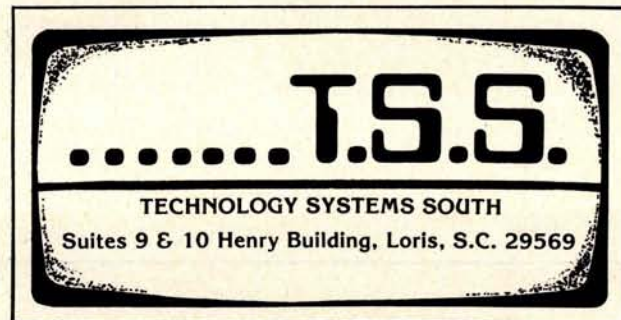

CCS has everything to expand your Apple II*

Friendly Frankie's roadside Apple II stand has plenty to whet your appetite for expansion. So, if you're ready to have your Apple II computer interface with the outside world, wheel around to Frankie's stand today.

Expand to your heart's content with our full range of delicious

accessories, including: prom modules, asynchronous and synchronous serial interfaces, arithmetic processors, programmable timers, parallel interfaces, A/D converters, and Apple II compatible boards galore.

Let Frankie connect your Apple II to the rest of the world

faster, and for a lot less bucks.

For all the mouth-watering details, contact our northern California headquarters or your local roadside computer store. If Frankie's out, ask for Dennis or Jerry. They'll be glad to help you.

*Apple II is a registered trademark of Apple Computers, Inc.

FRIENDLY FRANKIE'S FRESH APPLES

A/D
CONVERTER
\$149⁹⁵

PROM
MODULE
\$79⁹⁵

SERIAL
INTERFACE
\$159⁹⁵

PROGRAMMABLE
TIMER
\$159⁹⁵

PARALLEL
INTERFACE
\$119⁹⁵

ARITHMETIC
PROCESSOR
\$399⁹⁵

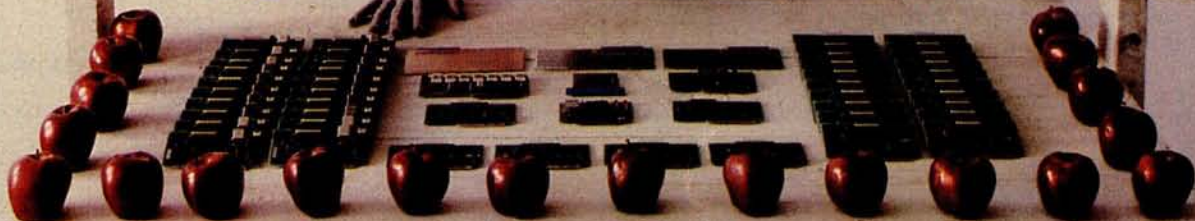

California Computer Systems

309 Laurelwood Road, Santa Clara, CA 95050, (408) 988-1620

So Nobody Goes Away Mad.

In addition to listing file entries, menu item 2 will revise entries. If a revision is made because new information has been found, simply enter the number (or name) of the person for whom the revisions are to be made, and then select the type of information that is to be updated. The revision subroutines are *document oriented*, that is, each asks for all of the information that is commonly found on a particular vital record. For example, the marriage revision subroutine requests the date of marriage, the spouse's name, the place where the marriage was performed, and the source from which the information was obtained,

because all of these items are found on a marriage certificate. The document orientation of the revision routines suits the genealogist's situation well, for the need to update information about an ancestor will usually arise from the discovery of a new document.

If you wish to revise an error that was made while entering information the first time, you should first finish entering all of the information requested by the program. The computer will then prompt for changes by going back to the original menu.

Item 2 will also generate blank data-collection forms which can be used for gathering information to

enter into the computer. This is done by putting a special symbol in the data fields for every relevant name,

PLEASE ENTER THE NUMBER OF THE PROCEDURE YOU WANT:

- (1) ENTER INFORMATION
- (2) READ OR REVISE INFORMATION
- (3) LIST PEDIGREE
- (4) END THE PROGRAM

?

Table 1: The genealogy program prompts the user for a specific use. The user can enter and modify information, list a person's pedigree for 4 generations, or finish the program use.

TASK: ADD GENEALOGICAL INFORMATION TO THE FILE

WHAT IS THE PERSON'S NAME?
(USE MAIDEN NAME WHERE APPROPRIATE)
? THOMAS MERRILL

TO PREVENT THOMAS MERRILL
FROM BEING CONFUSED WITH SOMEONE ELSE
WHO MAY HAVE A SIMILAR NAME, HE/SHE
SHOULD HAVE A UNIQUE NUMBER IN THIS FILE.

HAS A NUMBER ALREADY BEEN ASSIGNED?
? YES

PLEASE ENTER THE NUMBER:
? 14

I WILL ASK YOU FOR SOME DATES.
PLEASE ENTER DATES IN THE FOLLOWING
FORMAT: DAY MONTH YEAR
EXAMPLE: 23 APRIL 1949
IF YOU DON'T KNOW A DATE, ENTER 'UNKNOWN'.

WHEN WAS THOMAS MERRILL BORN (DA MO YR)?
? 20 NOVEMBER 1715

WHERE WAS HE/SHE BORN?
? HARTFORD CONNECTICUT

WHAT WAS THOMAS MERRILL'S FATHER'S NAME?
(IF YOU DON'T KNOW, ENTER 'UNKNOWN')
? ABEL MERRILL

DOES ABEL MERRILL ALREADY HAVE A NUMBER?
? Y

PLEASE ENTER HIS NUMBER:
? 15

WHAT WAS THOMAS MERRILL'S MOTHER'S NAME?
(USE MAIDEN NAME IF POSSIBLE. IF YOU
DON'T KNOW HER NAME, ENTER 'UNKNOWN')
? MEHITABLE EASTON

DOES SHE ALREADY HAVE A NUMBER?
? Y

PLEASE ENTER HER NUMBER:
? 16

WHERE DID YOU GET THE INFORMATION ABOUT
THOMAS MERRILL'S BIRTH AND PARENTAGE?
(BE SPECIFIC)
? BIRTH CERTIFICATE 13347A

HOW MANY TIMES WAS THOMAS MERRILL MARRIED?
(ENTER A DIGIT FROM 0 TO 99)
? 1

ENTER A DATE FOR MARRIAGE # 1 (DA MO YR)
? 5 OCTOBER 1755

WHAT WAS THE SPOUSE'S FULL NAME?
(USE MAIDEN NAME WHERE APPLICABLE)
? MARTHA WOOD

WHERE WERE THEY MARRIED?
? HARTFORD CONNECTICUT

WHERE DID YOU GET THE INFORMATION ABOUT MARRIAGE # 1 ?
? MARRIAGE CERTIFICATE 3445 B

WHEN DID THOMAS MERRILL DIE (DA MO YR)?
(IF YOU DON'T KNOW, ENTER 'UNKNOWN'.
IF HE OR SHE IS STILL LIVING, ENTER 'ALIVE'.)
? 16 JUNE 1814

WHERE DID HE/SHE DIE?
? HARTFORD CONNECTICUT

WHERE DID YOU GET THE INFORMATION ABOUT HIS/HER DEATH?
? DEATH CERTIFICATE 3988 C

Listing 1: When adding information to the file, the program prompts you for every input and describes the form that it should take. If an error is made during input, the rest of the information should be completed and the revise option chosen from the main menu upon completion.

TASK: READ AND REVISE FILE INFORMATION

DO YOU WISH TO SEARCH BY 'NAME' OR BY 'NUMBER'?
? NUMBER

PLEASE ENTER THE NUMBER:
? 14

GENEALOGICAL INFORMATION FOR:
THOMAS MERRILL
NUMBER: 14

BORN: 20 NOVEMBER 1715
BIRTHPLACE: HARTFORD CONNECTICUT

FATHER: ABEL MERRILL (NUMBER: 15)
MOTHER: MEHITABLE EASTON (NUMBER: 16)

MARRIED TO:
MARTHA WOOD
DATE: 5 OCTOBER 1755
PLACE: HARTFORD CONNECTICUT

DEATH DATE: 16 JUNE 1814
PLACE OF DEATH: HARTFORD CONNECTICUT

RECORDS SOURCE:
BIRTH AND PARENTAGE: BIRTH CERTIFICATE 13347A
MARRIAGE # 1 :MARRIAGE CERTIFICATE 3445 B
DEATH: DEATH CERTIFICATE 3988 C

DO YOU WISH TO CHANGE ANYTHING?
? NO

WOULD YOU CARE TO EXAMINE ANOTHER RECORD?
? YES

Listing 2: A file may be found and read by either name or number. When the data has been reviewed, the user may update the file using the revision command.

place, date, and source in item 1. (A question mark (?) makes a good symbol for this purpose. The number 0 can be used when the computer prompts for a number for the individual and his parents. The number 1 is a good response when the computer asks how many times the individual was married.) Either the special symbol or the number assigned by the program to the special form is then used in item 2. The number or symbol can be requested repeatedly to obtain as many copies of the form as are desired.

The program assigns a unique number to each ancestor so that it can differentiate between people with the same name. (My own genealogy contains cases where as many as 3 individuals have identical names.) Utilizing these numbers, the program

will link up any person in the file with 4 generations of his or her ancestors, thus forming a *pedigree chart*. An example of such a pedigree is shown in listing 3. It is not necessary that everyone in the file be related. The program can tell who is related to whom on the basis of the number assigned to each person.

Other Ideas

The genealogy program in listing 4 prompts you to enter important identifying information about your ancestors. It will print back this information and allow revisions. It will also print a 4 generation pedigree for any person in the file, but its usefulness need not stop there: your own imagination can provide per-

sonal additions. You might wish to expand the pedigree section to print out more generations, or write a subroutine which will sort persons of the file into nuclear family groups. You might choose to add a subroutine to calculate age of death for each ancestor and average age of death for subgroups of ancestors. This could provide insight into the impact of historical conditions on longevity in your family, and could even be applied toward figuring out your own life expectancy. Along these same lines, you could add a prompt for cause of death — an item usually found on a death certificate. Inspection of the cause of death for a large number of ancestors might even alert you to special diseases that occur regularly in your family.

TASK: LIST PEDIGREE

WHOSE PEDIGREE WOULD YOU LIKE PRINTED?
(ENTER HIS/HER NUMBER, PLEASE)
? 14

THE SYMBOL 'F' STANDS FOR 'FATHER'
THE SYMBOL 'M' STANDS FOR 'MOTHER'

PEDIGREE FOR PERSON # 14

THOMAS MERRILL

F:ABEL MERRILL (NUMBER: 15)
M:MEHITABLE EASTON (NUMBER: 16)

FF:JOHN MERRILL (NUMBER: 17)
FM:SARAH WATSON (NUMBER: 18)

MF:JOHN EASTON (NUMBER: 19)
MM:ELIZABETH (EASTON) (NUMBER: 20)

FFF:NATHANIEL MERRILL (NUMBER: 21)
FFM:SUSANNAH WOLVERTON (NUMBER: 22)

FMF:JOHN WATSON (NUMBER: 25)
FMM:MARGARET SMITH (NUMBER: 26)

MFF:JOSEPH EASTON (NUMBER: 27)
MFM:HANNAH (EASTON) (NUMBER: 28)

MMF:UNKNOWN (NUMBER: 0)
MMM:UNKNOWN (NUMBER: 0)

Listing 3: When a pedigree is requested, a person's ancestry is traced back 4 generations. If the ancestry is unknown, then this is stated.



9900

New easy-to-use educational module. Your best ticket to the microprocessor world. Ideal for teaching. Yourself. Or others.

TI's new TM990/189 University Module is a stand-alone learning lab. Fully assembled and designed for maximum hands-on experience. To ease and simplify learning and teaching.

Outstanding features include powerful 16-bit microprocessor with easy-to-learn, easy-to-use minicomputer instruction set; 45-key alphanumeric keyboard and ten-digit seven-segment display for easy assembly-language programming; ROM-resident software including system monitor for program debug and symbolic assembler; audio cassette interface; easy-to-add EIA and TTY interface; 1K-byte RAM expandable to 2K; 4K-byte ROM and 2K-byte expansion EPROM socket; 16-bit

programmable I/O controller; user addressable LEDs, and sound indicator.

A 570-page tutorial text accompanies the module. It is a detailed guide for self-paced learning. Or the basis for a three-hour university course. Chapters include an

overview of microprocessors; programming exercises; assembly language; memory systems; I/O concepts and designs; software engineering; product development; a variety of lab experiments, and much more. Also with the module: a 300-page user's guide.

The University Module complete with tutorial text and user's guide is only \$299.00.

Order your University Module from your authorized TI distributor. For more information, write Texas Instruments Incorporated, P.O. Box 1443, M/S 6404, Houston, Texas 77001.

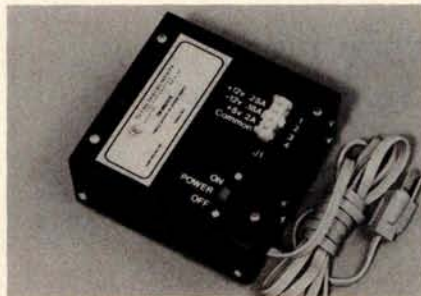

TM990/519 power supply is available for \$65.00.

**TEXAS INSTRUMENTS
MOVING AHEAD
IN MICROCOMPUTERS**



Circle 372 on inquiry card.

© 1979 Texas Instruments Incorporated

**TEXAS INSTRUMENTS
INCORPORATED**

85577

Our MacroFloppy™ goes twice the distance. For \$695.



Introducing the Micropolis MacroFloppy™:1041 and :1042 disk drive sub-systems. For the S-100/8080/Z-80 bus. Packing 100% more capacity into a 5¼-inch floppy disk than anyone else. 143K bytes, to be exact. For as little as \$695.

The MacroFloppy:1041 comes with the Micropolis Mod I floppy packaged inside a protective enclosure (without power supply). And includes an S-100 controller. Interconnect cable. Micropolis BASIC User's Manual. A diskette containing Micropolis BASIC, and a compatible DOS with assembler and editor. The :1041 is even designed to be used either on your desk top, or to be integrated right into your S-100 chassis.

The MacroFloppy:1042 comes with everything the :1041 has, and more. Such as d.c. regulators, its own line voltage power supply, and, to top it off, a striking cover. Making it look right at home just about anywhere.

Both MacroFloppy systems are fully assembled, tested, burned-in, and tested again. For zero start-up pain, and long term reliability. They're also backed up by our famous Micropolis factory warranty.

And both systems are priced just right. \$695 for the MacroFloppy:1041 and \$795 for the MacroFloppy:1042.

You really couldn't ask for anything more.

At Micropolis, we have more bytes in store for you.

For a descriptive brochure, in the U.S. call or write Micropolis Corporation, 7959 Deering Avenue, Canoga Park, California 91304. Phone (213) 703-1121.

Or better yet, see your local dealer.

MICROPOLIS™

More bytes in store for you.

Listing 4: The genealogical program source listing in BASIC Plus 2. Only the input and output statements will need to be changed to adapt this program to most microcomputers with disk storage.

```
00010 PRINT TAB(19);'GENEALOGICAL PROGRAM'
00020 !
00030 !   WRITTEN BY STAN W. MERRILL
00040 !           OF COMPUTER RESOURCE ASSOCIATES
00050 !           914 EAST SIXTY-FIRST STREET
00060 !           CHICAGO, ILLINOIS 60637
00070 !           (312) 363-6183
00080 !
00090 !   ALLOCATE FILE AND COUNT NUMBER OF CASES ALREADY IN IT
00100 !   SET COUNTERS
00110 !
00120 PRINT\PRINT\PRINT
00130 ON ERROR GO TO 350
00140 MAP GENDATA B,C$(3)=16,D$(25),E$(16),F,C$(3)=25,H$(20),J$(16),K$(3)=20
,L$(20),Q$(25),S$(25),R,T,D1$(40),D2$(3)=40,D3$(40)
00150 OPEN 'GEN' AS FILE #1, SEQUENTIAL VARIABLE, MAP GENDATA, INVALID
130
00160 LET I2=0
00170 LET I3=0 ! I3 COUNTS NUMBER OF CASES IN FILE
00180 !
00190 PRINT "WOULD YOU LIKE A LIST OF THE NAMES CURRENTLY"
00200 PRINT "IN THE FILE?"
00210 INPUT W1$
00220 PRINT
00230 IF W1$='Y' THEN PRINT "THE FILE CONTAINS THE FOLLOWING NAMES:"
00240 IF W1$='YES' THEN PRINT "THE FILE CONTAINS THE FOLLOWING NAMES:"
00250 PRINT
00260 GET #1
00270 LET I3=I3+1
00280 IF W1$='Y' THEN PRINT D$,B
00290 IF W1$='YES' THEN PRINT D$,B
```

Listing 4 continued on next page

This genealogy program was written on a DECsystem 2050 at the University of Chicago, using DEC's BASIC Plus 2. The file I/O (input/output) under BASIC Plus 2 differs from that in many other BASICs and may require some revision when running the program under another interpreter or compiler. For instance, the MAP statement, which BASIC Plus 2 uses to allocate space for variables, is unnecessary in some versions of BASIC.

To make the program smaller, reduce the number of prompts. Another possibility is to break the program into smaller programs, each of which can be loaded into memory independently as needed. The 3 major subroutines (labeled "procedure subroutines" in listing 4) are almost self-sufficient, that is, they can be entered as separate programs with only slight modification. However, procedure subroutine 2 calls several revision subroutines (lines 4170 thru 4850) which should be included with it, if it is made into a separate program.

MetaFloppy™ goes beyond.

The Micropolis MetaFloppy™ gives you more than four times the capacity of anyone else's 5¼-inch floppy. Because it uses 77 tracks instead of the usual 35.

The field-proven MetaFloppy, with thousands of units delivered, comes in a complete family of models. And, like our MacroFloppy™ family of disk drives, MetaFloppy is designed for the S-100/8080/Z-80 bus.

For maximum capacity, choose our new MetaFloppy:1054 system. Which actually provides you with more than a million bytes of reliable on-line storage. For less money than you'd believe possible.

The MetaFloppy:1054 comes complete with four drives in dual configuration. A controller. Power supply. Chassis. Enclosure. All cabling. A new BASIC software package. And a DOS with assembler and editor. There's even a built-in Autoload ROM to eliminate tiresome button pushing.

If that's more storage than you need right now, try our MetaFloppy:1053, with 630,000 bytes on-line. Or our MetaFloppy:1043, with 315,000 bytes on-line. Either way, you can expand to over a million bytes on-line in easy stages, when you need to. Or want to.

In other words, if your application keeps growing, we've got you covered. With MetaFloppy.

The system that goes beyond the floppy.

For a descriptive brochure, in the U.S. call or write Micropolis Corporation, 7959 Deering Avenue, Canoga Park, California 91304. Phone (213) 703-1121.

Or better yet, see your local dealer.



MICROPOLIS™

More bytes in store for you.

Another use for the information in the file is for studying naming traditions. Do certain names appear over and over in the family? Are surnames commonly used for given or middle names? Perhaps the file contains ideas for naming your own children (pets, etc). Studying names can help in the understanding of implicit family values and the transfer of power and prestige in the family.

You may wish to add a subroutine for collecting biographical anecdotes about ancestors. This is a real programming challenge, given the limited string handling capabilities of most versions of BASIC.

Conclusion

Genealogy matches you and your computer against exciting and worthwhile puzzles that challenge the best abilities of both man and machine. Its rewards include a closer relationship with your family, increased knowledge of history gleaned from a search for facts that may have affected ancestral migration and marriage patterns, and a self-knowledge derived from examination of people like yourself.

Listing 4 continued:

```

00300 !
00310 IF B>I2 THEN LET I2=B
00320 IF R>I2 THEN LET I2=R
00330 IF T>I2 THEN LET I2=T
00340 GO TO 260
00350 RESUME 390
00360 !
00370 !           MENU OF PROCEDURES
00380 !
00390 PRINT\PRINT\PRINT
00400 PRINT "PLEASE ENTER THE NUMBER OF THE PROCEDURE"
00410 PRINT "YOU WANT:"
00420 PRINT
00430 PRINT TAB(10);"(1) ENTER INFORMATION"
00440 PRINT TAB(10);"(2) READ OR REVISE INFORMATION"
00450 PRINT TAB(10);"(3) LIST PEDIGREE"
00460 PRINT TAB(10);"(4) END THE PROGRAM"
00470 INPUT A
00480 IF A=1 THEN GOSUB 570           !ENTER INFORMATION
00490 IF A=2 THEN GOSUB 2000        !READ THE INFORMATION
00500 IF A=3 THEN GOSUB 3090        !LIST PEDIGREE
00510 IF A=4 THEN GO TO 4900        ! END PROGRAM
00520 GO TO 390                      !INPUT ERROR—TRY AGAIN
00530 !
00540 !           PROCEDURE SUBROUTINE #1
00550 !           BIRTH CERTIFICATE INFORMATION
00560 !
00570 PRINT\PRINT
00580 PRINT "TASK: ADD GENEALOGICAL INFORMATION TO THE FILE"
00590 OPEN "GEN" FOR INPUT AS FILE #1, SEQUENTIAL VARIABLE, ACCESS
APPEND, MAP GENDATA, INVALID 130
00600 PRINT\PRINT
00610 PRINT "WHAT IS THE PERSON'S NAME?"

```

Listing 4 continued on page 32

Up Your Output.

TEMPOS

MULTI-TASKING!

The TEMPOS Operating System is quickly becoming the standard in Multi-User, Multi-Tasking operating systems for 8080 and Z80 microcomputers. Multi-Tasking means that, even with only one user at one terminal, more than one job can be running on the system *simultaneously!* If you have ever had to go get a cup of coffee while you wait for your computer to print listings, you *know* the advantages of a system that will handle one job while you are working on another. TEMPOS is a true time sharing system, and the maximum number of jobs is limited only by your memory.

MULTI-USER!

Want to share your computer with another user? With TEMPOS all it takes is another terminal... up to seven interactive terminals are allowed! And with Re-Entrant programs, each user does not need a complete copy in memory. We include three Re-Entrant programs (the OPUS/THREE High-Level Language, the TEXTED Text Editor, and FILES, a disc file directory/manipulator) or write your own! In addition, we include an assembler, a linking loader, over a half-dozen other utility programs and over 60 system subroutines, callable by the programmer!

PROVEN!

With TEMPOS, you get a package that has been tested in our facilities for over two years, and in the field at over 50 different installations. We have used this system ourselves for everything from writing high-level languages to developing applications to text editing to games. TEMPOS is undoubtedly the most flexible software tool on the market... and you can have it for much less than you think!

COMPATIBLE!

TEMPOS is available for many different systems; pre-written drivers may include yours. Or, using our interactive System Generation Routine, you can add your own. Call or write now for our free catalog and the name of a dealer near you. The TEMPOS Operating System is available for \$787.00, the manual set (price may be credited toward the purchase of the TEMPOS package) for \$21.50 (prices include shipping within the U.S.).

ADMINISTRATIVE
SYSTEMS
INC.

1642 S. Parker Road, Suite 300, Denver, Colorado 80231
(303) 755-9694

Listing 4 continued:

```
00620 PRINT "(USE MAIDEN NAME WHERE APPROPRIATE)"
00630 INPUT D$
00640 PRINT\PRINT
00650 PRINT "TO PREVENT ";D$
00660 PRINT "FROM BEING CONFUSED WITH SOMEONE ELSE"
00670 PRINT "WHO MAY HAVE A SIMILAR NAME, HE/SHE"
00680 PRINT "SHOULD HAVE A UNIQUE NUMBER IN THIS FILE."
00690 PRINT
00700 PRINT "HAS A NUMBER ALREADY BEEN ASSIGNED?"
00710 INPUT V$
00720 IF V$='Y' THEN 820
00730 IF V$='YES' THEN 820
00740 IF V$<>'N' THEN IF V$<>'NO' THEN GO TO 690
00750 LET I2=I2+1
00760 LET B=I2
00770 PRINT
00780 PRINT "HE/SHE HAS BEEN ASSIGNED THE NUMBER:"
00790 PRINT
00800 PRINT TAB(10);B
00810 GO TO 850
00820 PRINT
00830 PRINT "PLEASE ENTER THE NUMBER:"
00840 INPUT B
00850 PRINT\PRINT
00860 PRINT "I WILL ASK YOU FOR SOME DATES."
00870 PRINT "PLEASE ENTER DATES IN THE FOLLOWING"
00880 PRINT "FORMAT: DAY MONTH YEAR"
00890 PRINT " EXAMPLE: 23 APRIL 1949"
00900 PRINT "IF YOU DON'T KNOW A DATE, ENTER 'UNKNOWN'."
00910 PRINT\PRINT
00920 PRINT "WHEN WAS ";D$;" BORN (DA MO YR)?"
00930 INPUT E$
00940 PRINT
00950 PRINT "WHERE WAS HE/SHE BORN?"
00960 INPUT H$
00970 PRINT\PRINT
00980 PRINT "WHAT WAS ";D$;"S FATHER'S NAME?"
00990 PRINT "(IF YOU DON'T KNOW, ENTER 'UNKNOWN')"
```

Listing 4 continued on page 42

TAKE A GIANT STEP
FORWARD
IN PERSONAL
COMPUTING
WITH

OHIO SCIENTIFIC
OHIO SCIENTIFIC
OHIO SCIENTIFIC
OHIO SCIENTIFIC
OHIO SCIENTIFIC
OHIO SCIENTIFIC
OHIO SCIENTIFIC
OHIO SCIENTIFIC
OHIO SCIENTIFIC
OHIO SCIENTIFIC

Circle 300 on inquiry card.

YOUR NEXT COMPUTER

You know about computers. In fact, you probably own one now. One that you might be thinking of expanding. We have a better idea. Take a really giant step into the personal computing future with a C4P or C8P from Ohio Scientific. These two new premium computer systems offer the best specs in the personal computing industry with built-in performance levels that you could never achieve with your present system, even with all the add-ons available. We'll show you why.

THE FACTS SPEED

Speed separates the computers from the toys. The faster the processor executes instructions the more elaborate and greater the I/O can be. The C4P and C8P have execution speed that is twice as fast as Apple II, or Commodore PET and over THREE times as fast as TRS-80. They are many times faster than the recently introduced flock of video game type computers.

GT OPTION As if that weren't fast enough, the C4P and C8P's speed is nearly doubled when equipped with the Ohio Scientific GT option. By utilizing a 6502C microprocessor in conjunction with ultra-fast static memories, a C4P or C8P equipped with the GT option, will yield the following performance:

1.2 million instructions per second. Average.
Memory to accumulator ADD time — 600NS.
JUMP extended — 900NS.

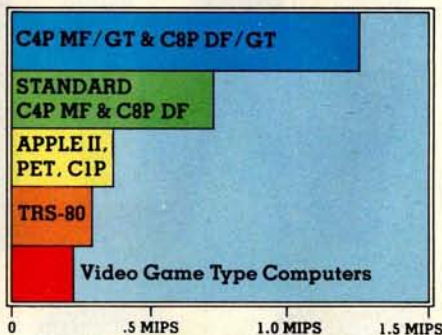

DISPLAY

The C4P and the C8P offer more display than other personal computers — 2048 characters — 32 rows of 64 columns with upper and lower case. Long display width makes user instruction easier to program and to read. The effective graphics resolution of 256 x 512 points allows these computers to match the display limit of even the best color television sets.

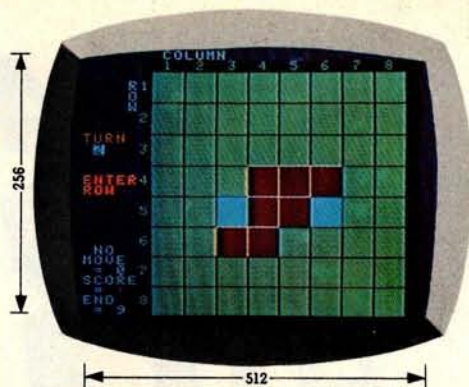
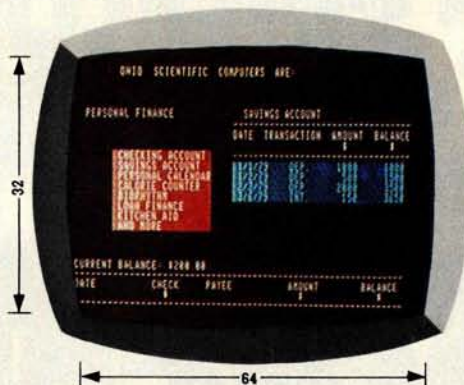
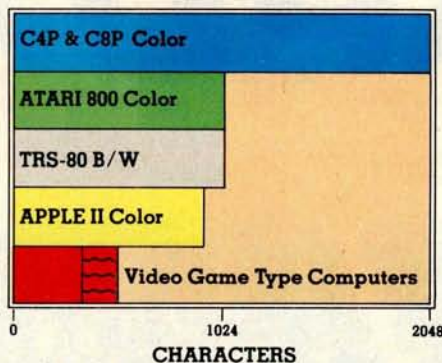

16 COLORS

The C4P and C8P offer a brilliant array of 16 colors including black available in both alphabetic and graphics.

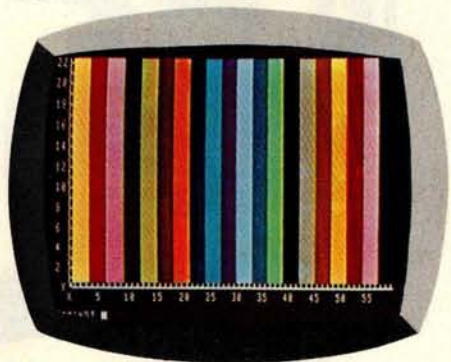

CONSTRUCTION

The C4P incorporates a fully RF shielded aluminum case with 2-step baked on enamel finish. It is trimmed with solid oiled walnut and die-cast chromed dress panels. Compare its construction to the plastic cases that are standard on other personal computers.

The quality doesn't stop at the surface. The C4P and C8P are modular BUS orientated computers with 4 and 8 slots respectively. The internal electronics are built to rigorous industrial standards.

Modularity means expandability and obsolescence protection. In fact, the original 1977 vintage C2-4P can be upgraded to a C4P by changing PC cards at substantially less cost than purchasing a new computer.

* Apple II, Commodore PET, TRS-80, and Atari 800 are registered trade names of Apple Computer Inc., Commodore Business Machines Ltd., Radio Shack, Atari, respectively.



The C4P MF is shown with optional accessories (clockwise). Home Color TV set (requires RF modulator), 2 joy sticks, AC-Remote console and 2 modules, wireless smoke detector and window detector, modem, printer and wireless remote security console (on top of TV.)

JUST LOOK AT ALL THE I/O OF THE C4P MF - BUILT IN

INTERFACES

I/O capabilities. The most important feature to look for when you purchase your next computer. Compare these standard features of the C4P and C8P disk systems to any other computer system. Regardless of price, you'll find none that even come close.



HOME SECURITY INTERFACES

1-home security interface with fire and intrusion detection

CONTROL INTERFACES

16 parallel I/O lines

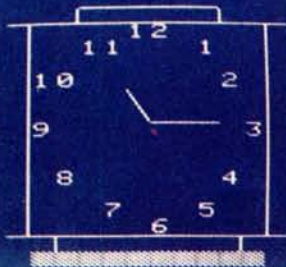
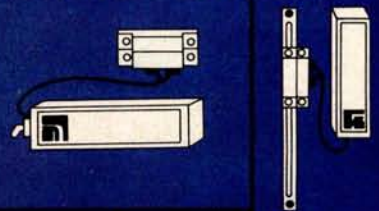

CLOCK

1-Real time clock and count down timer

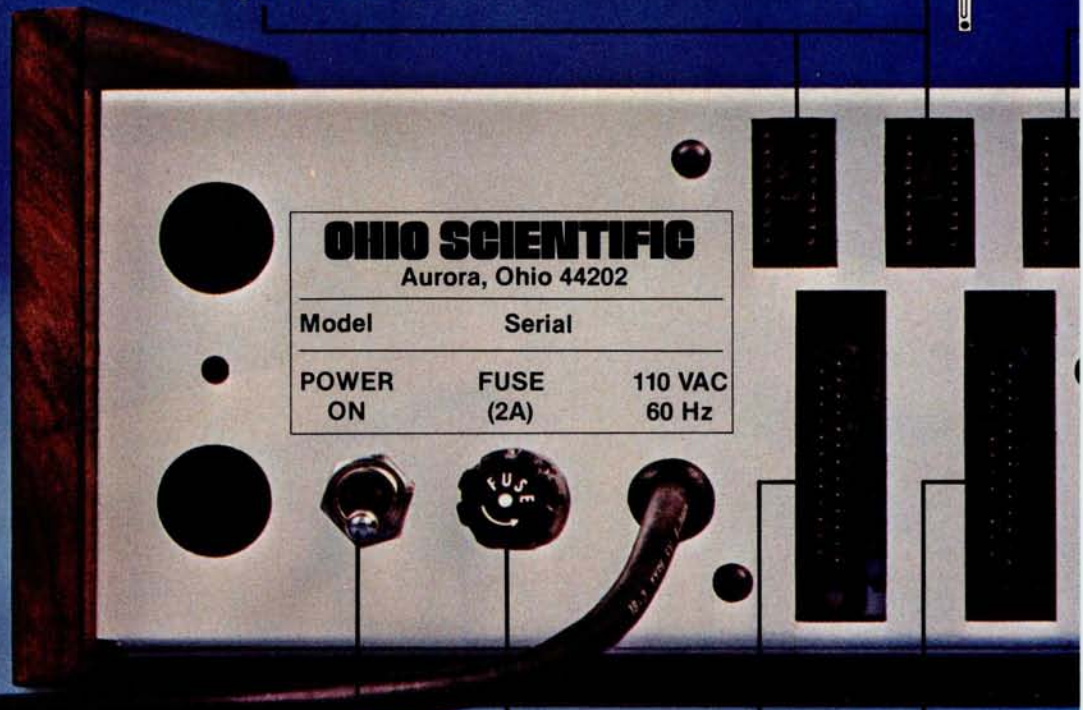

ON/OFF Switch Fuse

Only an Ohio Scientific C4P MF or C8P DF can offer you all this I/O.

RS - 232 PORTS

1-300 baud modem port
1-300/1200 baud printer port
Directly connect to an optional modem and printer



AVAILABLE ON THE BACK AND READY TO RUN.

ACCESSORY BUS

One accessory BUS connector for an external 48 line I/O board, PROM blaster, analog data module or education board.



SOUND

1-programmable tone generator 200 — 20KHz
1-8 bit companding digital to analog converter (DAC) for music and voice output

Cassette IN
(Cassette Versions Only)

Color Adj.

Video Display

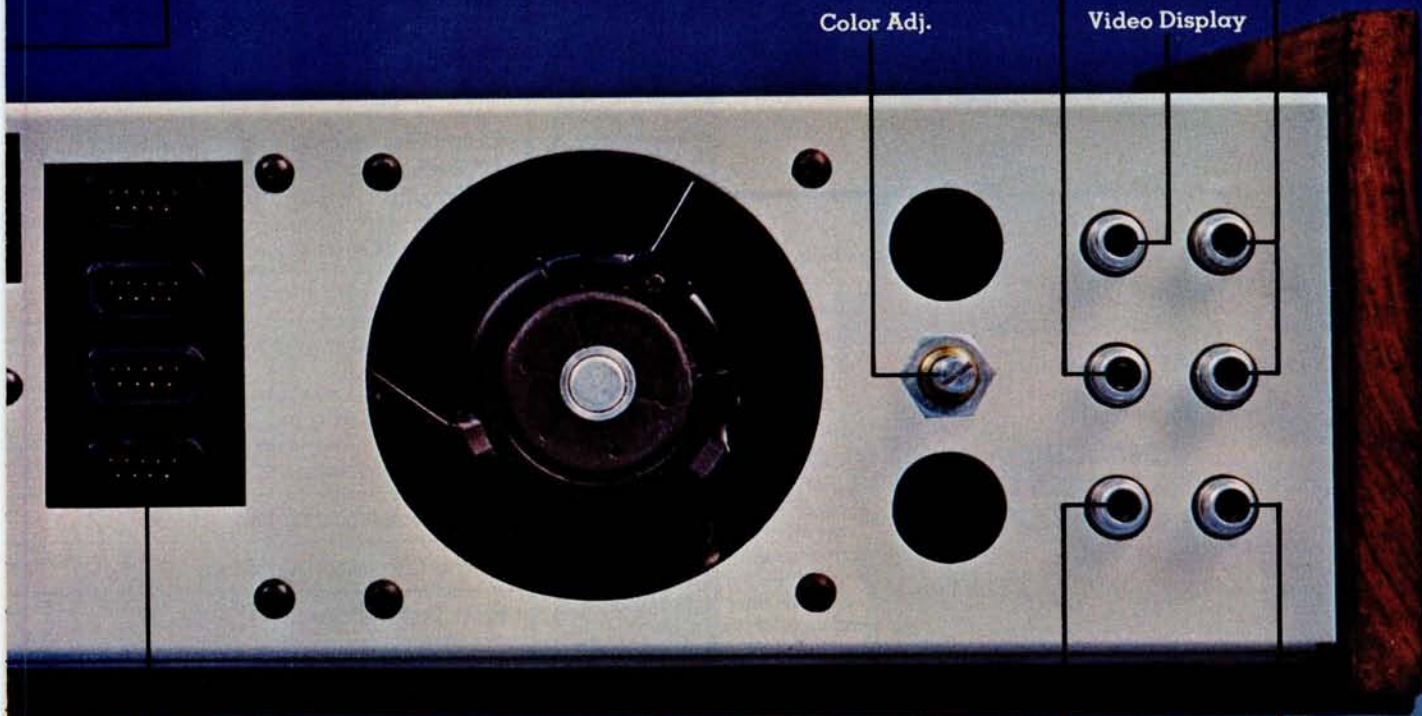

Cassette OUT
(Cassette Versions Only)

HUMAN INPUT EXPANSION

2-8 axis joystick interfaces
2-10 keypad interfaces

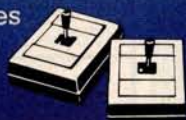

HOME INTERFACES

1—AC-12 AC remote control interface



HARDWARE

SOFTWARE

COMPUTERS

C4P	8K BASIC in ROM, 8K RAM, Demo Cassette	\$ 698
C4PMF	24K RAM, Single Mini-Floppy, OS-65D 3.1 operating system and 2 demo disks	1.695
C8P	8K BASIC in ROM, 8K RAM, Demo Cassette	895
C8PDF	32K RAM Dual 8" floppies, OS-65D 3.1 and 2 demo disks.	2.597

ACCESSORIES

AC-3P	12" B/W Combination Monitor/TV	\$ 115
AC-15P	12" Color Monitor	399
AC-16P	2-8 Axis Joy sticks with cables	39
AC-11P	Answer/Originate 300 baud modem with cable	199
AC-12P	AC-Remote starter set, console, 2 lamp modules, 2 appliance modules, OS-65D home control operating system.	175
AC-17P	Home security starter set (wireless), console, 1 fire detector 2-window units, one door unit and Demonstration software.	249
CA-15	Universal telephone interface with touch tone encoder / decoder, 300 baud originate / answer modem, analog signal mux / demux.	499
CA-15V	As above with Votrax voice module for computer generated voice response.	799

PRINTERS

AC-18P	Low cost high speed 8½" aluminized paper printer with upper/lower case.	\$ 695
AC-9TP	Centronics 779 110 cps tractor feed Business printer with interface.	1,250
AC-14	NEC Spinwriter—word processing printer with high speed parallel Interface.	2,795

GT OPTIONS (must be purchased with computer)

C4P MF/GT	24K, 120NS Memory, 6502C processor, 2-speed clock.	add \$ 950
C8P DF/GT	48K, 120NS Memory, 6502C processor, 2 speed clock.	add 1,825

For other expansion accessories such as add-on memory, additional floppy drives and other accessory boards consult the current full line price list.

Here is a partial listing of diskettes for the C4P and C8P. For a complete listing of diskettes and cassettes consult the current full line price list.

APPLICATIONS SOFTWARE

Game Disk 1	Arcade games	\$ 29
Game Disk 2	Arcade games	29
Game Disk 3	Popular Conventional Computer games	29
Game Disk 4	Popular Conventional Computer games	29
Game Disk 5	Advanced Arcade games	29
Game Disk 6	Advanced Arcade games	29
Game Disk 7	Joy stick Arcade games	29
Game Disk 8	Animations and Cartoons (2 disk set)	29
Personal Disk 1	Checking/Savings/Loans/Etc.	29
Personal Disk 2	More personal programs	29
Education Disk 1	Educational games	29
Education Disk 2	BASIC tutor series	29
Education Disk 3	Tests/tutors/drills	29

BUSINESS SOFTWARE

Business Disk 1	Depreciation/return on investments etc. . . .	\$ 29
Business Disk 2	Mailing list/Address list/etc. . . .	29
OS-WP2	Complete word processing system	200
OS-MDMS	65D based Data Base Manager and information management system. A must for business use.	49
MDMS-A/R	Accounts Receivable System	29
MDMS-A/P	Accounts Payable System	29
MDMS-Inventory	Inventory System	29
MDMS-Aux. 1	Sort/File packer/keyFile editor for ISAM	29

UTILITIES

65D Aux. 1	Sort/packer/memory test/disassembler	\$ 29
Graphics 1	Color graphics utilities with high resolution plot package	29
Home Control 2	Advanced home control program using AC-12 and AC-17	29
DAC Routines 1	Music composition system with chord generation capability	39

Purchase your C4P or C8P and accessories direct from your local Ohio Scientific dealer. Over 300 dealers nationwide.

OHIO SCIENTIFIC

1333 S. Chillicothe Road • Aurora, Ohio 44202 • (216) 562-3101



250/750

BREAKING THE SOUND BARRIER

ROBERT TINNEY

September 1977

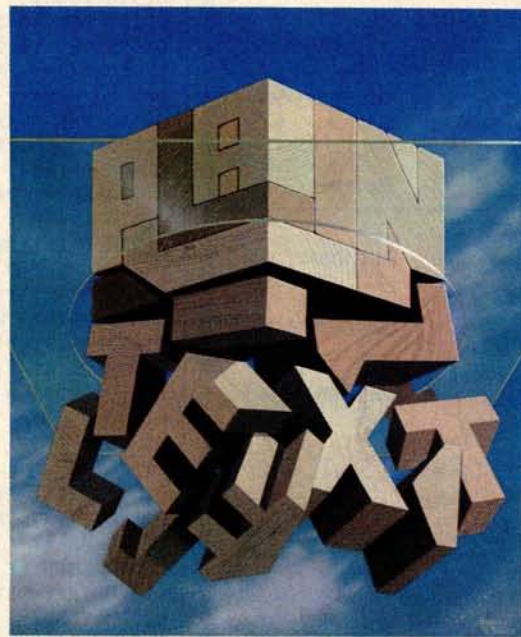

250/750

THE TRAP DOOR

ROBERT TINNEY

March 1979

Byte Cover Prints -- Limited Editions.

The September '77 and March '79 covers of BYTE are now each available as a limited edition art print, personally signed and numbered by the artist, Robert Tinney.

These prints are strictly limited to a quantity of 750 for each cover, and no other editions, of any size, will ever be published. Each print is 18" x 22", printed on quality, coated stock, and signed and numbered in pencil at bottom.

The price of each print is \$25. This includes 1) a signed and numbered print; 2) a Certificate of Authenticity, also signed personally by the artist and witnessed, attesting to the number of the edition (750), and the destruction of the printing plates; and 3) first class shipment in a heavy-duty mailing tube.

To order your limited edition art print, fill out and mail the order form below.

Send me _____ "Breaking the Sound Barrier" prints at \$25 each, and _____ "Trap Door" prints at \$25 each. I understand this price includes Certificate of Authenticity and first class shipment.

- I have enclosed check or money order to Robert Tinney Graphics.
 Charge this to my Master Charge or Visa

Card # _____ Expires: _____

Ship my print(s) to:

Name _____

Address _____

City _____ State _____ Zip _____

Send order to:

robert tinney graphics

P.O. Box 45047 • Baton Rouge, LA 70895



U.S. ROBOTICS, INC.

PENRIL 300/1200 MODEM

Originate/Auto-Answer

ALL NEW \$799.00



300 or 1200 Baud
Bell 212 Compatible
FCC Certified
RS232

Half/Full Duplex on
Dial-up Phone Lines
1 year warranty
Stand Alone



PERKIN-
ELMER
BANTAM

\$799.00

All the Features of the
Hazeltine 1400 & LSI ADM-3A
Plus

Upper/Lower Case
7 x 10 Char. Matrix
White or Black Char
Transparent Mode
Addressable Cursor

Tab Function
Backspace Key
Shiftlock Key
Print Key
Integrated Numeric
Pad

\$41.61 per month
Lease-Purchase



\$1095.00

TELETYPE
MODEL 43
KSR

with RS232
10 or 30 CHAR/SEC
132 COLUMNS
UPPER/LOWER CASE



USR-310
Originate
Acoustic
Coupler

\$159.00

0-300 Baud
Crystal Controlled

Stand Alone
RS232



USR-330
Originate
Auto-Answer
Modem

\$339.00

FCC Certified for Direct Connection
to Phone Lines

**USR-320 Auto-Answer
Only Modem \$319.00**

All Units include a 120 day warranty
Optional Maintenance package available

**Any Product may be returned
within 10 days for a full refund.**

U.S. ROBOTICS, INC.

1035 W. LAKE ST.
CHICAGO, ILL. 60607

Sales (312) 733-0497
General Offices (312) 733-0498
Service (312) 733-0499

Listing 4 continued:

```

01330 PRINT
01340 LET I2=I2+1
01350 LET T=I2
01360 PRINT "SHE HAS BEEN ASSIGNED THE NUMBER:"
01370 PRINT
01380 PRINT TAB(10);T
01390 GO TO 1450           ! GO BACK FOR NUMBER
01400 PRINT
01410 PRINT "PLEASE ENTER HER NUMBER:"
01420 INPUT T
01430 PRINT\PRINT
01440 LET T=0
01450 PRINT\PRINT
01460 PRINT "WHERE DID YOU GET THE INFORMATION ABOUT"
01470 PRINT D$;"S BIRTH AND PARENTAGE?"
01480 PRINT "(BE SPECIFIC)"
01490 INPUT D1$
01500 !
01510 !           MARRIAGE CERTIFICATE INFORMATION
01520 !
01530 PRINT\PRINT
01540 PRINT "HOW MANY TIMES WAS ";D$;" MARRIED?"
01550 PRINT "(ENTER A DIGIT FROM 0 TO 99)"
01560 INPUT F
01570 IF F=0 THEN GO TO 1730
01580 FOR I=1 TO F
01590 PRINT\PRINT
01600 PRINT "ENTER A DATE FOR MARRIAGE #";I;" (DA MO YR)"
01610 INPUT C$(I)
01620 PRINT
01630 PRINT "WHAT WAS THE SPOUSE'S FULL NAME?"
01640 PRINT "(USE MAIDEN NAME WHERE APPLICABLE)"
01650 INPUT G$(I)
01660 PRINT
01670 PRINT "WHERE WERE THEY MARRIED?"
01680 INPUT K$(I)
01690 PRINT\PRINT
01700 PRINT "WHERE DID YOU GET THE INFORMATION ABOUT MARRIAGE #";F;"?"
01710 INPUT D2$(I)
01720 NEXT I
01730 IF F=0 THEN C$(I)="NOT APPLICABLE"
01740 IF F=0 THEN G$(I)="NOT APPLICABLE"
01750 !
01760 !           DEATH CERTIFICATE INFORMATION
01770 !
01780 PRINT\PRINT
01790 PRINT "WHEN DID ";D$;" DIE (DA MO YR)?"
01800 PRINT "(IF YOU DON'T KNOW, ENTER 'UNKNOWN'.)"
01810 PRINT "IF HE OR SHE IS STILL LIVING, ENTER 'ALIVE'.)"
01820 INPUT J$
01830 IF J$="ALIVE" THEN GO TO 1900
01840 PRINT\PRINT
01850 PRINT "WHERE DID HE/SHE DIE?"
01860 INPUT L$
01870 PRINT\PRINT
01880 PRINT "WHERE DID YOU GET THE INFORMATION ABOUT HIS/HER DEATH?"
01890 INPUT D3$
01900 IF J$="ALIVE" THEN L$="NOT APPLICABLE"
01910 PRINT\PRINT\PRINT
01920 !
01930 PUT #1
01940 CLOSE #1
01950 RETURN
01960 !
01970 !           PROCEDURE SUBROUTINE #2
01980 !           READ AND REVISE FILE
01990 !
02000 PRINT\PRINT
02010 PRINT "TASK: READ AND REVISE FILE INFORMATION"
02020 PRINT\PRINT
02030 OPEN "GEN" AS FILE #1, SEQUENTIAL VARIABLE, ACCESS MODIFY, MAP GEN
    
```

Listing 4 continued on page 44

DIGI-KIT-IZER

What it means to you.

dig·i·kit·izer /dij·e·kit·izer/ *n.* (1): a high-value low-cost computer graphic input device designed to be assembled by the user (2): the most advanced graphics tablet in kit form (3): An instrument that, when assembled, allows the user innumerable methods of design and analysis functions (4): The latest addition to the most extensive, accurate and reliable line of digitizers, by Talos



\$449.

No adjustments. No calibration.

OPTIONS

- APPLE Interface
- TRS-80 Interface
- RS 232 Interface
- Power Supply
- IC Sockets
- Unit Enclosure

Dealer inquiries invited

PLEASE RUSH ADDITIONAL INFORMATION ON THE
TALOS DIGI-KIT-IZER

Name _____

Company _____

Title _____

Address _____

City _____ State _____ Zip _____

Phone _____

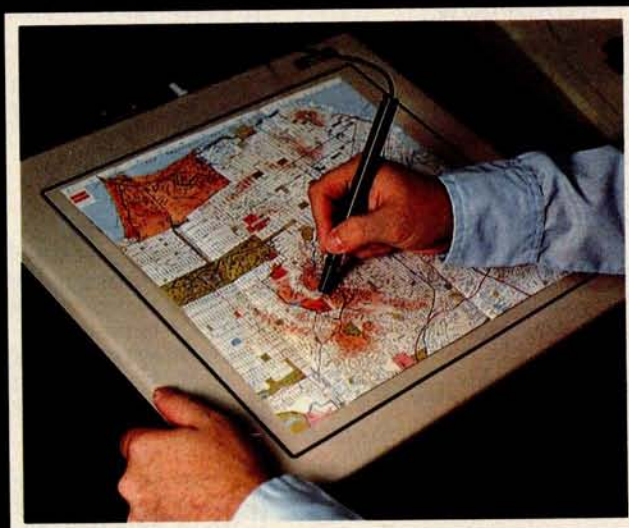

by **talos**

TALOS SYSTEMS INC.
7419 E. Helm Drive
Scottsdale, Arizona 85260
(602) 948-6540
TWX (910) 950 1183

CHECK YOUR LOCAL DEALER NOW

Multi Variable Task

software
system

FAMOS™

MULTI-TASKING DOS:

- 8080/z80
- Device independent file system
- Multi-sessioning/spooling
- Full user accounting
- All files dynamic
- Multi-user file security
- Intersystem communications

\$100 BUS SUPPORT

MVT-BASIC™

MULTI-USER COMPILER

- Powerful file, string I/O
- Chaining . . . parameter passing
- ISAM/sort facilities
- Random, sequential files
- Machine language calls
- Error trapping

HARD DISKS SUPPORTED

MVT-WORDFLOW™

MULTI-USER WORD PROCESSING SYSTEM

- Concurrent data processing
- Automatic field insertion
- Global search/replace
- Library file insertion
- "Cutting & pasting"/block moves
- Full WP printer support
- Multiple printers/concurrent
- Wordwrap/variable line spacing
- All options under user control

IMMEDIATE DELIVERY

AVAILABLE TO MANUFACTURERS/
OEM FOR PRIVATE LABEL
MARKETING



9241 Reseda Blvd., Suite 203
Northridge, CA 91324
Phone: (213) 349-9076

Listing 4 continued:

```

DATA, INVALID 130
02040 PRINT "DO YOU WISH TO SEARCH BY 'NAME' OR BY 'NUMBER'?"
02050 INPUT W2$
02060 PRINT
02070 IF W2$="NAME" THEN GO TO 2200
02080 IF W2$<>"NUMBER" THEN GO TO 2040
02090 PRINT "PLEASE ENTER THE NUMBER:"
02100 INPUT A1
02110 PRINT
02120 RESTORE #1
02130 LET Z5=0
02140 LET Z5=Z5+1
02150 IF Z5>I3 THEN PRINT "PERSON #";A1;"IS NOT IN THE FILE."
02160 IF Z5>I3 THEN GO TO 2940
02170 GET #1
02180 IF A1<>B THEN GO TO 2140
02190 GO TO 2340
02200 PRINT "IF YOU ARE LOOKING FOR SOMEONE IN PARTICULAR"
02210 PRINT "PLEASE ENTER HIS OR HER NAME. IF YOU WANT"
02220 PRINT "TO READ THROUGH THE ENTIRE FILE, ENTER 'ALL'."
02230 INPUT P1$
02240 PRINT
02250 LET P2$=P1$
02260 RESTORE #1
02270 LET Z5=0
02280 LET Z5=Z5+1
02290 IF Z5>I3 THEN PRINT P1$;" IS NOT IN THE FILE."
02300 IF Z5>I3 THEN GO TO 2940
02310 GET #1
02320 IF P1$="ALL" THEN LET P2$=D$
02330 IF P2$<>D$ THEN GO TO 2280
02340 PRINT\PRINT
02350 PRINT "GENEALOGICAL INFORMATION FOR:"
02360 PRINT D$
02370 PRINT "NUMBER:";B
02380 PRINT
02390 PRINT "BORN: ";E$
02400 PRINT "BIRTHPLACE: ";H$
02410 PRINT
02420 PRINT "FATHER: ";Q$;" (NUMBER:";R;"")
02430 PRINT "MOTHER: ";S$;" (NUMBER:";T;"")
02440 PRINT
02450 IF F=0 THEN GO TO 2530
02460 PRINT "MARRIED TO:"
02470 FOR I=1 TO F
02480 PRINT " ";G$(I)
02490 PRINT " DATE: ";C$(I)
02500 PRINT " PLACE: ";K$(I)
02510 PRINT
02520 NEXT I
02530 IF J$="ALIVE" THEN GO TO 2560
02540 PRINT "DEATH DATE: ";J$
02550 PRINT "PLACE OF DEATH: ";L$
02560 PRINT\PRINT
02570 PRINT "RECORDS SOURCE:"
02580 PRINT " BIRTH AND PARENTAGE: ";D1$
02590 FOR I=1 TO F
02600 PRINT " MARRIAGE #";F;" ";D2$(I)
02610 NEXT I
02620 IF J$="ALIVE" THEN GO TO 2640
02630 PRINT " DEATH: ";D3$
02640 PRINT\PRINT
02650 !
02660 PRINT "DO YOU WISH TO CHANGE ANYTHING?"
02670 INPUT P3$
02680 IF P3$="N" THEN GO TO 2930
02690 IF P3$="NO" THEN GO TO 2930
02700 !
02710 ! MENU FOR REVISIONS
02720 !
02730 PRINT

```

Listing 4 continued on next page

Listing 4 continued:

```

02740 PRINT 'PLEASE ENTER THE NUMBER OF THE ITEM'
02750 PRINT 'YOU WISH TO CHANGE:'
02760 PRINT
02770 PRINT ' 1) NAME AND NUMBER'
02780 PRINT ' 2) BIRTH AND PARENTAGE'
02790 PRINT ' 3) MARRIAGE INFORMATION'
02800 PRINT ' 4) DEATH INFORMATION'
02810 PRINT ' 5) NOTHING'
02820 PRINT
02830 INPUT P4
02840 IF P4=1 THEN GOSUB 4190
02850 IF P4=2 THEN GOSUB 4300
02860 IF P4=3 THEN GOSUB 4460
02870 IF P4=4 THEN GOSUB 4670
02880 IF P4=5 THEN GO TO 2940
02890 PRINT
02900 !
02910 PRINT 'DO YOU WISH TO MAKE OTHER CHANGES?'
02920 GO TO 2670
02930 UPDATE #1, MAP 140
02940 PRINT\PRINT
02950 !
02960 PRINT 'WOULD YOU CARE TO EXAMINE ANOTHER RECORD?'
02970 INPUT P$
02980 IF P$='Y' THEN IF P1$<>'ALL' THEN GO TO 2030
02990 IF P$='YES' THEN IF P1$<>'ALL' THEN GO TO 2030
03000 IF P$='Y' THEN GO TO 2310
03010 IF P$='YES' THEN GO TO 2310
03020 !
03030 CLOSE #1
03040 RETURN
03050 !
03060 !      PROCEDURE SUBROUTINE #3
03070 !      LINK PEDIGREE BY NUMBER
03080 !
03090 PRINT\PRINT
03100 PRINT "TASK: LIST PEDIGREE"
03110 PRINT\PRINT
03120 OPEN 'GEN' AS FILE #1, SEQUENTIAL VARIABLE, MAP GENDATA, INVALID
130
03130 LET I4=0
03140 PRINT "WHOSE PEDIGREE WOULD YOU LIKE PRINTED?"
03150 PRINT "(ENTER HIS/HER NUMBER, PLEASE)"
03160 INPUT X1
03170 PRINT\PRINT
03180 PRINT "THE SYMBOL 'F' STANDS FOR 'FATHER'"
03190 PRINT "THE SYMBOL 'M' STANDS FOR 'MOTHER'"
03200 PRINT\PRINT
03210 !
03220 !      FIND PARENTS AND LIST
03230 !
03240 LET I4=I4+1
03250 IF I4>I3 THEN PRINT "PERSON #";X1;"IS NOT LISTED IN THE FILE"
03260 IF I4>I3 THEN GO TO 4150
03270 GET #1
03280 IF B<>X1 THEN GO TO 3240
03290 PRINT TAB(15);"PEDIGREE FOR PERSON #";B
03300 PRINT
03310 PRINT D$
03320 PRINT
03330 PRINT TAB(5);"F:";O$;"(NUMBER:";R;")"
03340 PRINT TAB(5);"M:";S$;"(NUMBER:";T;")"
03350 PRINT
03360 !
03370 !      FIND GRANDPARENTS AND LIST
03380 !
03390 LET X2=R
03400 LET X3=T
03410 LET I5=0
03420 LET I12=0
03430 IF X2<>0 THEN I12=I12+1

```

Listing 4 continued on page 46

A.C. POWER CONTROL for ALL COMPUTERS or COMPLETE TURNKEY SYSTEMS



Interface TO the Real World with GIMIX Relay Driver Boards. Connects to any Computer through a 20 ma. current loop (up to 4 Boards-128 Relays per port).

Interface FROM the Real World with GIMIX

- ★ OPTO BOARDS (up to 34 switch closures with one 8 bit Parallel I/O Port)
- ★ 16 BUTTON KEYPADS
- ★ 35 BUTTON ALPHANUMERIC KEYPADS

A Broad Range of 6800 Systems and Boards Compatible with the SS50 Bus

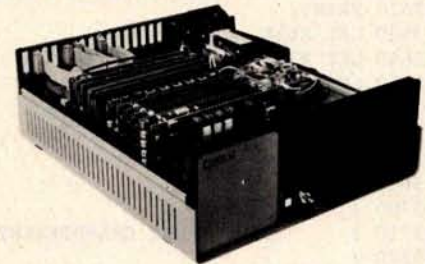

MAINFRAME: Includes chassis, power supply, switches, fan and mother board... **\$ 798.19**

16K SYSTEMS: Mainframe, plus 6800 CPU, 16K Static Ram and choice of I/O... **\$1344.29**
Other packages available.

16K Static RAM Boards for the SS-50 Bus

- Gold bus connectors
- 4 separate 4K Blocks
- Individual Addressing, Write Protect, and Enable/Disable for each block

\$298¹³



Memories...

As above with Sockets and Software control features
\$368¹⁶

All GIMIX memory boards are assembled, Burnt-In for 2 weeks, and tested at 2 MHz. Add \$32.00 for 250 ns parts

TI TMS 4044's — 10% SUPPLY
(Not an "equivalent", but the real thing!)

450 ns	\$5.90 each	250 ns	\$6.90 each
8K PROM BOARD	\$ 98.34		
4K PPD PROM BOARD, Burner and Duplicator	198.35		
2708's	each 7.90		
64 or 32 x 16 VIDEO BOARD	198.71		
80 x 24 SUPER VIDEO BOARD with user programmable RAM character generator	458.76		
Serial I/O's	1 Port	\$ 88.41	4 Port 198.43
Parallel I/O's	2 Port	\$ 88.42	8 Port 198.45

Add \$5. handling charge on orders under \$200.

GIMIX INC.

1337 WEST 37th PLACE
CHICAGO, ILLINOIS 60609
(312) 927-5510 • TWX 910-221-4055

Quality Electronic products since 1975.

Listing 4 continued:

```

03440 IF X3<>0 THEN I12=I12+1
03450 IF I12=0 THEN GO TO 4150
03460 LET I4=I4+1
03470 IF I4=I3 THEN GOSUB 4840
03480 GET #1
03490 IF X2=B THEN GO TO 3520
03500 IF X3=B THEN GO TO 3600
03510 GO TO 3460
03520 PRINT TAB(10);'FF: ';QS; '(NUMBER: ';R;')'
03530 PRINT TAB(10);'FM: ';SS; '(NUMBER: ';T;')'
03540 PRINT
03550 LET X4=R
03560 LET X5=T
03570 LET I5=I5+1
03580 IF I5<I12 THEN GO TO 3460
03590 IF I5>=I12 THEN GO TO 3730
03600 PRINT TAB(10);'MF: ';QS; '(NUMBER: ';R;')'
03610 PRINT TAB(10);'MM: ';SS; '(NUMBER: ';T;')'
03620 PRINT
03630 LET X6=R
03640 LET X7=T
03650 LET I5=I5+1
03660 IF I5<I12 THEN GO TO 3460
03670 IF I5>=I12 THEN GO TO 3730
03680 LET I15=0
03690 PRINT
03700 !
03710 !         FIND GREAT GRANDPARENTS AND LIST
03720 !
03730 LET I5=0
03740 LET I12=0
03750 IF X4<>0 THEN I12=I12+1
03760 IF X5<>0 THEN I12=I12+1
03770 IF X6<>0 THEN I12=I12+1
03780 IF X7<>0 THEN I12=I12+1
03790 IF I12=0 THEN GO TO 4150
03800 LET I4=I4+1
03810 IF I4>I3 THEN GOSUB 4840
03820 IF I16>4 THEN PRINT "FURTHER TRACING OF
THE PEDIGREE IS IMPOSSIBLE."
03840 IF I16>4 THEN GO TO 4150
03850 GET #1
03860 IF X4=B THEN GO TO 3910
03870 IF X5=B THEN GO TO 3970
03880 IF X6=B THEN GO TO 4030
03890 IF X7=B THEN GO TO 4090
03900 GO TO 3800
03910 PRINT TAB(15);'FFF: ';QS; '(NUMBER: ';R;')'
03920 PRINT TAB(15);'FFM: ';SS; '(NUMBER: ';T;')'
03930 PRINT
03940 LET I5=I5+1
03950 IF I5<I12 THEN GO TO 3800
03960 IF I5>=4 THEN GO TO 4150
03970 PRINT TAB(15);'FMF: ';QS; '(NUMBER: ';R;')'
03980 PRINT TAB(15);'FMM: ';SS; '(NUMBER: ';T;')'
03990 PRINT
04000 LET I5=I5+1
04010 IF I5<I12 THEN GO TO 3800
04020 IF I5>=I12 THEN GO TO 4150
04030 PRINT TAB(15);'MFF: ';QS; '(NUMBER: ';R;')'
04040 PRINT TAB(15);'MFM: ';SS; '(NUMBER: ';T;')'
04050 PRINT
04060 LET I5=I5+1
04070 IF I5<I12 THEN GO TO 3800
04080 IF I5>=I12 THEN GO TO 4150
04090 PRINT TAB(15);'MMF: ';QS; '(NUMBER: ';R;')'
04100 PRINT TAB(15);'MMM: ';SS; '(NUMBER: ';T;')'
04110 PRINT
04120 LET I5=I5+1
04130 IF I5<I12 THEN GO TO 3800
04140 !
04150 CLOSE #1
04160 RETURN

```

```

04170 !
04180 !         REVISION SUBROUTINE #1
04190 !         CHANGE NAME AND NUMBER
04200 !
04210 PRINT\PRINT
04220 INPUT 'NAME: ';D$
04230 PRINT
04240 INPUT 'NUMBER: ';B
04250 RETURN
04260 !
04270 !         REVISION SUBROUTINE #2
04280 !         CHANGE BIRTH INFORMATION
04290 !
04300 ! CHANGE BIRTH INFORMATION
04310 PRINT\PRINT
04320 INPUT 'BIRTHDATE: ';E$
04330 PRINT
04340 INPUT 'BIRTHPLACE: ';H$
04350 PRINT
04360 INPUT "FATHER'S NAME";Q$
04370 INPUT "FATHER'S NUMBER";R
04380 PRINT
04390 INPUT "MOTHER'S NAME";S$
04400 INPUT "MOTHER'S NUMBER";T
04410 PRINT
04420 INPUT "SOURCE OF INFORMATION";D1$
04430 RETURN
04440 !
04450 !         REVISION SUBROUTINE #3
04460 !         CHANGE MARRIAGE INFORMATION
04470 !
04480 PRINT\PRINT
04490 INPUT "WHICH MARRIAGE (ENTER NUMBER)";I
04500 PRINT
04510 INPUT "DATE OF MARRIAGE #";I;
04520 INPUT C$(I)
04530 PRINT
04540 INPUT "SPOUSE'S NAME";G$(I)
04550 PRINT
04560 INPUT "PLACE OF MARRIAGE";K$(I)
04570 PRINT
04580 INPUT "SOURCE OF INFORMATION?"
04590 INPUT D2$(I)
04600 PRINT
04610 PRINT "FOR HOW MANY OF THIS PERSON'S MARRIAGES DOES"
04620 PRINT "THE FILE NOW CONTAIN INFORMATION?"
04630 INPUT F
04640 RETURN
04650 !
04660 !         REVISION SUBROUTINE #4
04670 !         CHANGE DEATH INFORMATION
04680 !
04690 PRINT\PRINT
04700 PRINT "DEATH DATE"
04710 PRINT "(IF YOU DON'T KNOW, ENTER 'UNKNOWN'. IF"
04720 PRINT "HE OR SHE IS STILL ALIVE, ENTER 'ALIVE'.)"
04730 INPUT J$
04740 IF J$='ALIVE' THEN GO TO 4800
04750 PRINT
04760 INPUT "PLACE OF DEATH";L$
04770 PRINT
04780 INPUT "SOURCE OF INFORMATION?"
04790 INPUT D3$
04800 RETURN
04810 !
04820 !         RESTORATION OF FILE POINTER
04830 !
04840 RESTORE #1
04850 RETURN
04860 !
04870 !         PROCEDURE SUBROUTINE #4
04880 !         END THE PROGRAM
04890 !
04900 PRINT
04910 END ■

```

The Paper Tiger.™

At \$995, why settle for less.

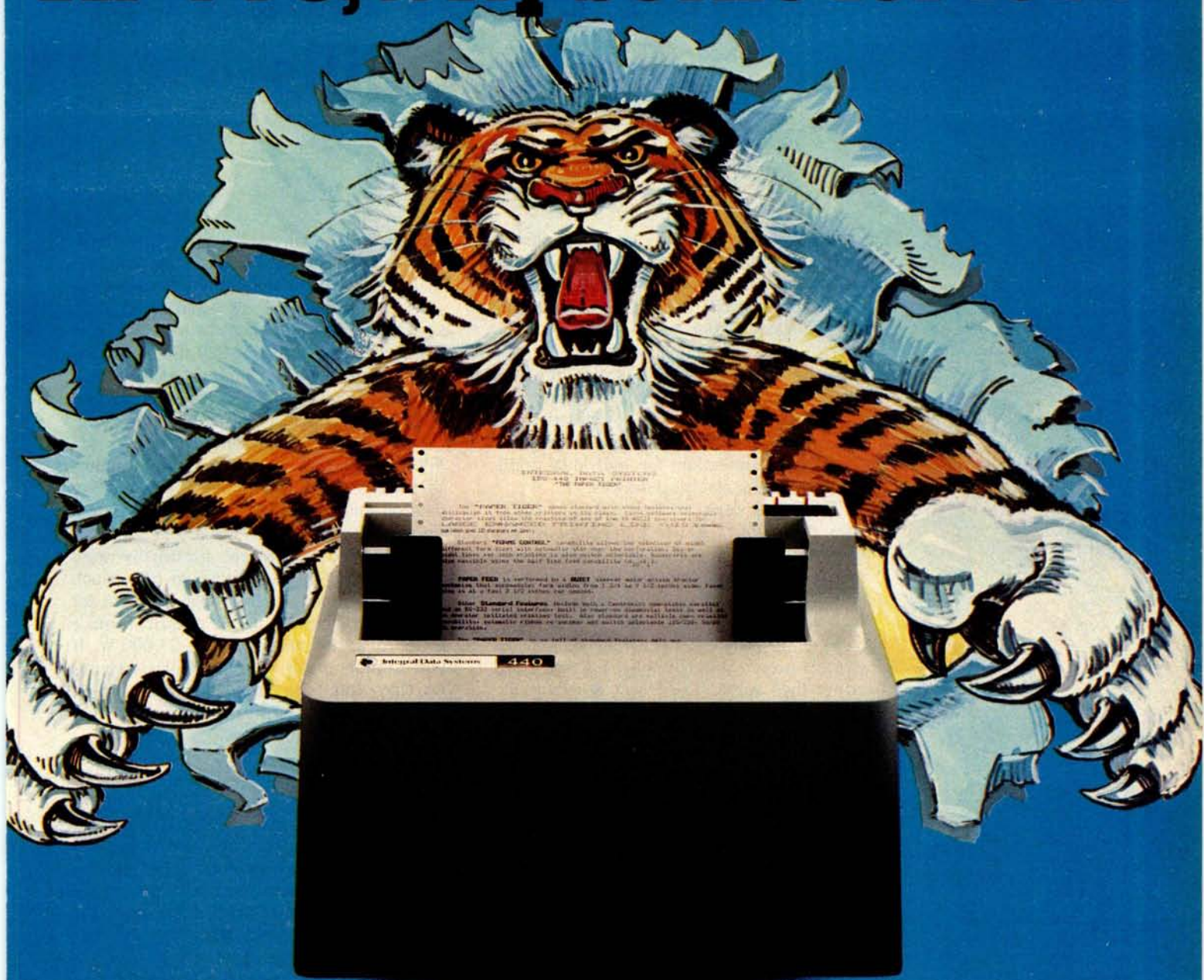

The Paper Tiger sets a new standard for low-cost impact printers. More capability. More versatility.

- Eight software-selectable character sizes.
- 80 and 132 column formats.
- Full forms control.
- DotPlot™ graphics option.
- Connects directly to Apple II, TRS-80, and other personal computers.

Plus lots more. For a free brochure, print sample, or the name of the Paper Tiger dealer nearest you, write or call. Integral Data Systems, 14 Tech Circle, Natick, Massachusetts 01760.

Call toll-free 800-343-6412.
In Massachusetts, Alaska, and Hawaii,
call (617) 237-7610.



Circle 176 on inquiry card.

Integral Data Systems, Inc.

Power Helps Analyze Electric Bills

Karen S Wolfe
2935 E Cannon Dr
Phoenix AZ 85028

We all know there are many reasons for increasing utility costs, from higher oil prices to billion dollar Environmental Protection Agency regulations, but that doesn't make the paying any easier.

There has been much rhetoric about personal conservation and elimination of waste. In order to formulate an effective and efficient plan for conservation of electricity in your home or business, you need to know the cost of operation for individual appliances and other electrical devices.

The Power program (see listing 1) calculates from your electric bill your cost per kilowatt-hour of power used. The program then generates the cost per month and per hour to operate specific appliances, given their electrical specifications.

name plate fastened somewhere on the device. However, some appliances list amps rather than watts. The Power program contains an option for calculating wattage from amperage and voltage.

You will also need the listed voltage, which will usually appear as 120 V or 120 V AC. If voltage is given in a range of, say, 110 V to 130 V, it means that the appliance will operate at any voltage within the range. In the program, use the voltage which is running through the circuit that the appliance is plugged into.

A table of household appliances is provided for your convenience in gathering and recording needed inputs and monthly costs. A word of warning about the estimation of hours an appliance is operated in a month: I repeatedly underestimate this time, perhaps because it seems that months fly by and hours are inconsequential. But there are 720 hours in a 30-day month and in order to make this analysis useful one must realistically estimate hours of use.

Another problem can exist in obtaining an estimated wattage for some of the high power consumption devices such as electric furnaces, or air conditioning units. New

models, today, will have many of their technical specifications listed in information sheets available to the public. Among these specifications will be an estimate of total system power requirement in kilowatts. For the sample run in listing 2, I used the total system kilowatts that were listed for a heat pump during its cooling cycle, given various other criteria such as outdoor temperature.

The listed power requirement was 6.3 kilowatts; however, the program requires that watts, not kilowatts, be entered. If the data on your equipment is in kilowatts, multiply by 1,000 to obtain watts.

Home electric furnaces are usually rated at 5 kW and up depending on how much heat is required. A very rough estimate for an average home with an electric furnace is 15 to 25 kW, or 15,000 to 25,000 W. If you cannot obtain your particular system's wattage, you might try using this average, but it could be significantly different from your actual system's draw.

Sample Run

The Power program, listing 1, is written in North Star BASIC. There are no instructions for providing hardcopy, but if you desire one you could place a statement for selecting your printer at, perhaps, line 415. You could then select the video monitor again at line 495.

The program presents two options. If you already know the cost per kilowatt-hour the utility company uses to calculate your bill, you can select option 2. This allows you to input the cost per kilowatt-hour by jumping to the main portion of the program.

If you do not know the kilowatt-hour rate, select option 1, as in the example. Actually, your cost per kilowatt-hour will probably vary from one month to the next because of the rating structure systems used by power companies, especially if time of day rates are being used. So, you just might

no loose ends

All-In-One: computer, floppy, I/O, 16K RAM. \$1595*

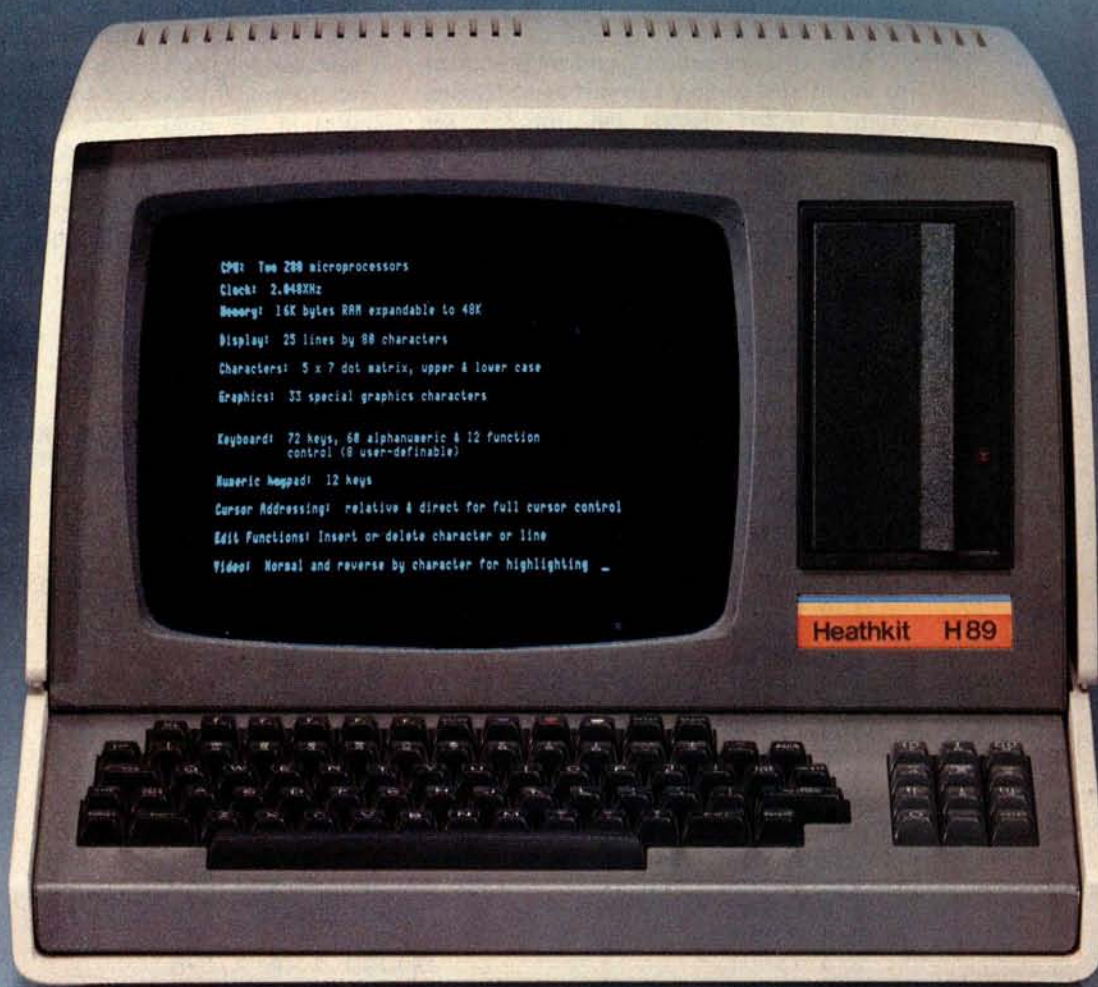

New Heathkit® H89 All-In-One Computer

Heath takes the risk out of selecting a balanced computer system. Now, video terminal, floppy, keyboard and 8-bit computer are brought together in one self-contained, compact unit. Nothing hangs out.

Two Z80's

The personal computer has never been simpler. Or smarter. Two Z80 microprocessors mean terminal never shares power with computer, as do most desk-top units. So this terminal is capable of a multitude of high-speed functions, all controllable by keyboard or software.

*\$1195 without floppy. Mail order kit price, F.O.B. Benton Harbor, MI. Also available at Heathkit Electronic Centers at slightly higher prices. Prices subject to change without notice.

102K bytes storage

Built-in floppy disk system gives you fast access to programs and data. Each 5¼-inch diskette has more than 102K bytes of storage area, enough to hold entire files. The All-In-One comes with 16K RAM, expandable to 48K.

Hundreds of uses at home or work

The All-In-One Computer runs programs written in MICROSOFT™ BASIC and ASSEMBLER Languages. And it accepts all current software written for the popular Heathkit H8 computer. You can choose from scores of practical programs for home and business.

Learn by building

What better way to learn about computers than to build one yourself? The All-In-One is available in easy-to-build kit form, as well as completely assembled. Like all Heath electronic kits, it comes to you with its own easy-to-follow assembly manual and a nationwide network of service centers to assure smooth sailing.

FREE CATALOG



For complete details on the Heathkit H89 All-In-One Computer and nearly 400 other electronic kits for your home, work or pleasure, send today for the latest Heathkit Catalog of values.

Heathkit®

HEATH COMPANY, DEPT. 334-580, BENTON HARBOR, MI 49022

CP-170

out of curiosity calculate your cost per kilowatt-hour each month as you get your bill and see if it is changing. Sometimes there are different rate block structures between summer and winter.

After entering option 1, you are prompted to input the ending kilowatt-hour reading from a recent electric bill (66,239, for example). Next, input the previous reading, which should also appear on the bill (62,213, for example).

The program prompts you to enter the

amount of the bill. If your utility company sells both electricity and gas to you, be certain that only the electric portion of the bill is entered. There may also be a fuel adjustment cost figured into the total cost, and sales tax will probably appear on the bill. It's up to you if you want to include these figures in the total cost you enter into the program. If you do include them, you can apportion their cost to individual appliances. The cost per kilowatt-hour will probably not be affected significantly whether you do or

Listing 1: North Star BASIC program to calculate the cost of running electrical appliances. The program helps you determine the operating cost of an appliance based on the average wattage or the voltage and amperage ratings of the product.

```

10 DIM D$(1)
20 PRINT "          THIS PROGRAM CALCULATES POWER USAGE AND COSTS"
30 PRINT\ PRINT
40 PRINT "          PROGRAM OPTIONS:"
50 PRINT
60 PRINT "          1. CALCULATE COST PER KILOWATT HOUR"
70 PRINT "          2. CALCULATE APPLIANCE POWER USAGE AND COST"
80 PRINT
90 INPUT "          SELECT 1 OR 2 ",A
100 PRINT
110 ON A GOTO 120, 200
120 INPUT "ENTER ENDING KWH READING FROM ELECTRIC BILL ",E
130 PRINT
140 INPUT "ENTER BEGINNING KWH READING FROM BILL ",B
150 PRINT
160 INPUT "ENTER AMOUNT OF ELECTRIC BILL ",T
170 PRINT
180 LET C = T/(E-B)
190 GOTO 220
200 INPUT "ENTER COST PER KWH ",C
210 PRINT\ PRINT
220 PRINT "          OPTIONS"
230 PRINT
240 PRINT "          1. CALCULATE WATTS"
250 PRINT "          2. INPUT WATTS"
260 PRINT
270 INPUT "          SELECT 1 OR 2 ",A
280 PRINT
290 ON A GOTO 300, 350
300 INPUT "ENTER APPLIANCE VOLTAGE ",V
310 PRINT
320 INPUT "ENTER APPLIANCE AMP DRAW ",Z
330 LET W = Z * V
340 GOTO 360
350 INPUT "ENTER APPLIANCE WATTAGE ",W
360 PRINT
370 INPUT "ENTER NUMBER OF HOURS USED IN TIME PERIOD ",H
380 PRINT
390 LET K = (W*H)/1000
400 LET D = K * C
410 PRINT\ PRINT\ PRINT
420 PRINT "          COST PER KILOWATT HOUR OF USAGE = ",C
430 PRINT
440 PRINT "          KILOWATT HOURS OF POWER USAGE = ",K
450 PRINT
460 PRINT "          MONTHLY COST OF THAT POWER USAGE= ",D
470 PRINT
480 PRINT "          COST PER EST. HOUR'S USE = ",D/H
490 PRINT\ PRINT
500 INPUT "DO YOU WISH TO CALCULATE ANOTHER APPLIANCE (Y/N)? ",D$
510 IF D$ = "Y" THEN 210
520 END

```

MicroNET

Big-system performance for your personal computer.



MicroNET is a remote on-line computing service available through local phone lines in 27 major metropolitan areas. It is a service for personal computer users provided by CompuServe, one of the nation's leading computer service companies.

Services available:

- Ability to communicate with other small computer users
 - Ability to buy and sell software through the network
 - Practical personal programs
 - Time-saving business applications
 - Educational aids
 - Easy-to-use programming languages
 - Advanced programming and diagnostic tools
 - Entertaining games
- Plus up to 64 K bytes of on-line file storage.

MicroNET users can access our large-scale computer systems in offpeak hours, from 6 P.M. to 5 A.M. local time weekdays and all day on weekends and most holidays. The cost, which will be billed to your Master Charge or Visa Card, is only \$5.00 per hour of computer time. There is a one-time sign-up charge of \$9.00.

Circle 54 on inquiry card.

Equipment required

A personal computer or computer terminal with communications capability and a telephone.

Please send me more information:

Mail to:

CompuServe

Personal Computing Division
5000 Arlington Centre Blvd.
Columbus, Ohio 43220

Send me information on MicroNET.

Name _____

Address _____

City/State/ZIP _____

MicroNET

Cities with local phone service access: Akron, Atlanta, Boston, Canton, Chicago, Cincinnati, Cleveland, Columbus, Dallas, Dayton, Denver, Detroit, Houston, Indianapolis, Los Angeles, Louisville, Memphis, West Caldwell (NJ), New York, Philadelphia, Pittsburgh, San Francisco, Stamford (CT), St. Louis, Toledo, Tucson, Washington, D.C.

Software Authors—see separate ad on page 120.

Table 1: This table can be used to collect data from your appliances for the Power program.

Appliance Power Table

Appliance	Watts or amps and volts	Hours used per month	Monthly cost	Cost per hour of use
Coffee maker				
Microwave oven				
Oven				
Range				
Dishwasher				
Refrigerator				
Freezer				
Clothes dryer				
Clothes washer				
Electric blanket				
Stereo				
Television				
Lawn mower				
Electric saw				
Lighting				
Sewing machine				
Air conditioner				
Dehumidifier				
Electronic air filter				
Fan				
Electric furnace				
Electric hot water heater				
Waterbed heater				
Swimming pool filter				

Listing 2: A sample run using the Power program.

```

THIS PROGRAM CALCULATES POWER USAGE AND COSTS

PROGRAM OPTIONS:

1. CALCULATE COST PER KILOWATT HOUR
2. CALCULATE APPLIANCE POWER USAGE AND COST

SELECT 1 OR 2 1

ENTER ENDING KWH READING FROM ELECTRIC BILL 66239
ENTER BEGINNING KWH READING FROM BILL 62213
ENTER AMOUNT OF ELECTRIC BILL 170.71

OPTIONS

1. CALCULATE WATTS
2. INPUT WATTS

SELECT 1 OR 2 1

ENTER APPLIANCE VOLTAGE 120
ENTER APPLIANCE AMP DRAW 3
ENTER NUMBER OF HOURS USED IN TIME PERIOD 100

```

Listing 2 continued on page 54

do not include these additional costs. In the sample run, we will enter \$170.71 for the total cost of electricity.

The program now presents two more options: to calculate watts from amps and volts, or to input watts. In the example we wish to calculate watts, so we enter 1. We are prompted to enter the appliance voltage, in this case 120. Then we enter the amps, in this case 3. The number of hours used a month is estimated at 100.

The calculations are quickly done and four results are presented. The inputs in this example were for a sewing machine and now I know what it's costing me to keep repairing my 5 year old's torn clothes. The first result shown is the cost per kilowatt-hour, which was calculated from the utility bill. Notice the E-02 at the end of the number. This floating point notation means that you move the decimal point two places to the left for a dollars and cents answer. Therefore, the utility company rate on my last bill averaged out to be \$0.04 per kilowatt-hour of use.

The next result is the number of kilowatt-hours of power used for the sewing machine. This is the product of the kilowatt draw times the estimated hours of use. Your electric meter records the total number of kilowatt-hours of usage; this is what appears on your bill. In this case, 36 kWh of my total usage were due to the sewing machine.

The monthly cost of using the machine is shown next. In this example, it cost me \$1.53 to operate my sewing machine for 100 hours during the month. That doesn't seem too bad. In fact, the next result presented shows me that one hour's usage of the machine costs me about 1½ cents. That's a bargain!

The program now asks if we wish to calculate costs for another appliance. To do so we enter Y.

The program already has calculated the cost per kilowatt-hour, so we loop back to the options for entering or calculating wattage. The next appliance I want to check is a portable color television for which I know the wattage. So, we enter option 2 for this prompt.

The wattage for the television is 240, so this figure is entered as prompted. The estimated hours of usage in a month are 200. The results show me that running that television for 200 hours cost me \$2.04 and the cost for each hour's use was \$0.01.

I want to enter a third appliance, a heat pump air conditioner. The watts are 6,300 and the estimated hours of use were 300. The results are significant, revealing a total cost of \$80.14 and a cost per hour of \$0.27. You can see the implications for conservation.



Special from ACS... New Low Cost Add-On Storage for your TRS-80®

TRS-80® Owners . . . ACS makes it easy for you to add-on disk storage with mini-disk storage systems...102k bytes of additional on-line storage.

● COMPARE AND SAVE

The FD-200™ drive from ACS lets you store 102.4k bytes of data on one side of the disk...compared to only 80k bytes on a TRS-80® mini-disk drive....and 102.4k bytes on the other side, as well. That's almost 205k bytes per mini-disk, something you can't do with a TRS-80® drive. Completely compatible with your TRS-80®. Can be used as No. 0, 1, 2 or 3-drive.

4-DRIVE CABLE\$35.00

● AVAILABLE IMMEDIATELY

Ready when you are...one-, two-, three-, and four-drive systems from ACS.

● NEW LOWER PRICE

Good news from ACS...a single-drive FD-200™ cost you only \$375.

Add \$20.00 for DOS 3.0 disk after September 1, 1979.

\$375.

Circle 9 on inquiry card.



Orders received by 6:00 p.m. shipped within 3 days on Master Charge, Visa, Certified Check or Money Order. Personal Checks require 14 days to clear. No C.O.D. Collect calls not accepted. All Hardware warranted for 90 days. Software guaranteed for replacement only. Prices subject to change without notice.

**AUTOMATED
COMPUTER
SOFTWARE SERVICE**
(615) 244-2798

Division of
Computer World INC.
625 Main Street • Nashville, TN 37206
Circle 9 on inquiry card

ORDER NOW AND SAVE!

Send Check or Money Order payable to -

ACS • 625 Main Street • Nashville, TN 37206

Quan.	Description	Unit Price	Total

Check
 Money Order
 MasterCharge
 Visa
 Card No. _____
 Exp. Date _____

HANDLING CHARGE \$1.50
 TENN. RES. ADD 6% SALES TAX **TOTAL**

Name _____
 Address _____
 City _____ State _____ Zip _____

® TRS-80 is a registered trademark of Radio Shack, a division of Tandy Corp.

COST PER KILOWATT HOUR OF USAGE = 4.2401888E-02
 KILOWATT HOURS OF POWER USAGE = 36
 MONTHLY COST OF THAT POWER USAGE= 1.526468
 COST PER EST. HOUR'S USE = .01526468

DO YOU WISH TO CALCULATE ANOTHER APPLIANCE (Y/N)? Y

OPTIONS

1. CALCULATE WATTS
2. INPUT WATTS

SELECT 1 OR 2 2

ENTER APPLIANCE WATTAGE 240

ENTER NUMBER OF HOURS USED IN TIME PERIOD 200

COST PER KILOWATT HOUR OF USAGE = 4.2401888E-02
 KILOWATT HOURS OF POWER USAGE = 48
 MONTHLY COST OF THAT POWER USAGE= 2.0352906
 COST PER EST. HOUR'S USE = 1.0176453E-02

DO YOU WISH TO CALCULATE ANOTHER APPLIANCE (Y/N)? Y

OPTIONS

1. CALCULATE WATTS
2. INPUT WATTS

SELECT 1 OR 2 2

ENTER APPLIANCE WATTAGE 6300

ENTER NUMBER OF HOURS USED IN TIME PERIOD 300

COST PER KILOWATT HOUR OF USAGE = 4.2401888E-02
 KILOWATT HOURS OF POWER USAGE = 1890
 MONTHLY COST OF THAT POWER USAGE= 80.139568
 COST PER EST. HOUR'S USE = .26713189

DO YOU WISH TO CALCULATE ANOTHER APPLIANCE (Y/N)? N

Pay As You Turn On

After you have calculated individual power costs for appliances, the next step is to use the information to conserve energy and lower your bill. The first thing that should strike you is how little most appliances really cost to operate per month. The second impact will be how expensive certain other items are to use.

Look at the appliance table and decide if you can decrease the hours used for these most costly items. Set a lower hour goal and then recalculate the monthly cost. When you think you have a workable goal that will help your budget, try to realize those desired hours of usage. Achieving the goals will demand your own personal determination and discipline. The Power program can show you problem areas and help establish targets and priorities, but that's where your battle really begins.

Perhaps, on/off timers would be helpful in regulating certain devices. Another approach that has been attempted is a "pay as you turn on" method. With the cost per hour of use figure from the program, you can charge yourself accordingly for the privilege of turning on specific appliances, such as televisions, washing and drying machines, ovens, ranges, electric lawn mowers or stereos (even your personal computer, heaven help us!).

Putting pennies into a bank on top of the television may sound a bit primitive but perhaps it would make one check the television listings in the paper more carefully before switching on the set and turning the selector to see if there's anything on worth watching.

I hope the Power program will aid in energy conservation. But its informational possibilities, alone, make it useful. At least you can know more clearly which devices are most power hungry and by how much. This is certainly better than receiving your electric bill and simply grumbling in the dark. ■

Cmc

KIM ANALOG INPUT

Analog to Digital Conversion System for the KIM Computer

DAM SYSTEMS

Give the KIM the ability to sense, measure, and control the world around it with DAM SYSTEMS modules. Just plug the KIMSET1 into the KIM to set 16 channels of analog input. Screw terminals are provided for each channel so you can hook up joysticks, pots, or whatever appropriate sensors you have. Each of the 16 analog inputs, in the range of 0 to 5.12 volts, is converted to a decimal number between 0 and 255 (20 millivolts per count). Conversion time is 100 microseconds. The KIMMOD provides one user port as well as a DAM SYSTEMS port. Software is provided.

KIMSET 1

- 1-AIM161 - 16 ANALOG INPUTS - 8 BITS - 100 MICROSEC
- 1-KIMMOD - KIM ADAPTER - 1 USER PORT - 1 DAM SYSTEMS PORT
- 1-CABLE A24 - 24 INCH INTERCONNECT CABLE
- 1-MANMOD1 - MANIFOLD MODULE - SCREW TERMINALS FOR INPUTS, REFERENCE, GROUND
- 1-POW1 - POWER MODULE

KIMSET1a for 110 VAC \$ 285
 KIMSET1e for 230 VAC \$ 295

Order direct or contact your local computer store.

CONNECTICUT microCOMPUTER, Inc.

150 POCONO ROAD
 BROOKFIELD, CONNECTICUT 06804

TEL: (203) 775-9659 TWX: TLX: 7104560052

VISA AND M/C ACCEPTED - SEND ACCOUNT NUMBER, EXPIRATION DATE AND SIGN ORDER.
 ADD \$3 PER ORDER FOR SHIPPING & HANDLING - FOREIGN ORDERS ADD 10% FOR AIR POSTAGE

Introducing the First CP/M Compatible Desktop Computer with Color Graphics.

The new Intecolor 8063 is the first desktop computer to combine the advantages of color alphanumerics and graphics with the versatility of CP/M. For unprecedented flexibility at a price within the reach of most small businesses, the Intecolor 8063 is the answer.

What does CP/M mean to you? An abundant selection of readily available software. There are CP/M programs for most business applications, minimizing the need for specially-prepared software.

Load the CP/M Operating System Disk and you're ready to run any CP/M program (without modifica-

tion), whether it's in BASIC, FORTRAN IV, or any other programming language. Add the superb readability and improved comprehension of color graphics and you've got unparalleled desktop performance.

Standard features of the Intecolor 8063 include a 19" color display with an 80 character x 48 line format, 32K of user RAM (expandable to 48K), and a dual 8" floppy disk drive with 591K bytes of storage (expandable to 1.1 megabytes).

Plus you get ISC's color version of Microsoft® Business BASIC on floppy disk. All for just \$5995.* Incredible? Indeed, and only from ISC, the world's largest supplier of color CRT terminals.

If your application calls for it, Microsoft FORTRAN IV is available from ISC for \$150.00.*

So if you want to spend more time computing than programming, contact your ISC sales representative today. Or check out the 8063 at selected computer dealers. CP/M in color. Only from ISC.

Color Communicates Better



*U.S. Domestic prices. Unretouched photo of screen. Furniture not included. CP/M is a registered trademark of Digital Research Corp.

ISC SALES REPRESENTATIVES: AL 205/883-8660. AZ 602/994-5400. AR (TX) 214/661-9633. CA Alhambra 213/281-2280. Goleta 805/964-8751. Irvine 714/557-4460. Los Angeles 213/476-1241. Mountain View 415/964-9300. San Diego 714/292-8525. CO 303/779-0666. CT 203/491-3585. DE (PA) 215/542-9876. DC (VA) 703/569-1502. FL Ft. Lauderdale 305/776-4800. Melbourne 305/723-0766. Orlando 305/425-5505. Tallahassee 904/878-6642. GA 404/449-5961. HI 808/524-8633. ID (UT) 801/973-7969. IL (No.) 312/564-5440. (So.) (MO) 816/765-3337. IN (IL) 312/564-5440. IA (MO) 816/765-3337. KS (MO) 816/765-3337. KY (OH) 513/429-9040. LA 504/626-9701. ME (MA) 617/729-5770. MD (VA) 703/569-1502. MA Cambridge 617/661-9424. Winchester 617/729-5770. MI 313/227-7067. MN 612/822-2119. MS (AL) 205/883-8660. MO 816/765-3337. MT (CO) 303/779-0666. NB (MO) 816/765-3337. NH (MA) 617/729-5770. NJ (No.) 201/224-6911. (So.) 215/542-9876. NV (AZ) 602/994-5400. NM 505/292-1212. NY Metro/LI 201/224-6911. Fairport 716/223-4490. No. Syracuse 315/669-2651. Utica 315/732-1801. NC 919/682-2383. ND (MN) 612/822-2119. OH Cleveland 216/464-8113. Columbus 614/436-2051. Dayton 513/429-9040. OK (TX) 214/661-9633. OR 503/620-5800. PA East 412/922-5110. West 215/542-9876. RI (MA) 617/729-5770. SC 803/798-8070. SD (MN) 612/882-2119. TN 615/482-5761. TX Dallas 214/661-9633. El Paso Area (Las Cruces, NM) 505/523-0601. Houston Only 713/780-2511. UT 801/973-7969. VT (MA) 617/729-5770. VA 703/569-1502. WA 206/455-9180. WV (PA) 412/922-5110. WI (IL) 312/564-5440. WY (CO) 303/779-0666.

EUROPEAN EXPORT SALES: EUROPE (MA) 617/661-9424. BELGIUM Brussels 02-242 36-04. FRANCE Rueil Malmaison 749-40-37. GREECE Athens 642-1368. ITALY Roma 805-647/872-457.

THE NETHERLANDS: Poeldijk 01749-7640. **SPAIN:** Barcelona 204 17 43. **SWEDEN:** Vallingby 08-380-370. **SWITZERLAND:** Mutschellen 057-546-55. **UNITED KINGDOM:** Bournemouth 0202-293-115.

WEST GERMANY: München 089-31881. **AUSTRALIA & NEW ZEALAND:** Auckland 814-9385. Canberra 58-1811. Chermides 59-6436. Melbourne 03-543-2077. Sydney 02-808-1444. Wellington 64-4585.

CANADA: Datamex Ltd. (Distributor) Dorval 514/636-9774. Ottawa 613/224-1391. Toronto 416/787-1208. Vancouver 604/684-8625. **CENTRAL & SOUTH AMERICA & CARIBBEAN:** (GA) 404/394-9603.

MEXICO: Monterrey 564-876. **FAR EAST:** (CA) 213/382-1107. **HONG KONG:** 5-742211. **JAPAN:** Tokyo 402-8596. **TAIWAN:** Taipei 02-7026284. **MIDDLE EAST:** ISC P.O. Box 48541. Atlanta, GA 30362. 404/581-0284. **IRAN:** Tehran 891148. **ISRAEL:** Tel Aviv 266-291. **KUWAIT:** Kuwait 438 180/1/2. **LEBANON:** Beirut 221731 260110. **SAUDI ARABIA:** Jeddah 27790. Riyadh 25083-39732.

For sales and service in other countries contact ISC headquarters in Norcross, GA, U.S.A.



Intelligent Systems Corp.

□ 5965 Peachtree Corners East □ Norcross, GA 30071 □ Telephone 404-449-5961 □ TWX 810-766-1581

Circle 181 on inquiry card.

BYTE October 1979 55

One of the best values computers is now



\$1995 SPECIAL SYSTEM PRICE

includes H8 Computer with 16K memory, four-port serial I/O and operating software, plus H17 Floppy Disk System (shown here with optional second drive) and H19 CRT Terminal — all in kit form.

Heathkit H8 Computer

- 8080A CPU has more software written for it than any other CPU
- 7 plug-in board positions for flexibility in configuring your system
- Up to 65K memory capacity
- Front panel keyboard for direct access to registers and memory

\$289 kit purchased separately. Was **\$379**. **You save \$90.**
\$349.00 assembled

Heathkit H17 Floppy Disk System

- Instant access to programs and data
- 102K bytes storage area
- 250 mS typical random access time

- Includes interface controller board
\$495.00 kit purchased separately
\$550.00 assembled

Heathkit H19 Smart Video Terminal

- Z80 microprocessor-controlled
 - 25 x 80, upper and lower case
 - Direct cursor addressing
 - 8 user-programmable keys
- \$675.00** kit purchased separately
\$995 assembled

5% discount on software, memory and interfacing

Special 5% discount applies to all software, memory and interface

boards when purchased with the H8 system.

Seven plug-in board positions on the H8 let you configure any combination of memory and I/O's that suits you. Heathkit memory boards come in 16K, 8K and 4K increments. Interface boards are available for parallel, serial and cassette I/O's.

Wide selection of software

Software for the H8 Computer includes operating systems software, MICROSOFT™ BASIC, FORTRAN, wordprocessing, plus innovative applications software for business and pleasure.

HUG has over 400 programs

An extensive library of programs is available to owners of Heathkit Com-

in high-performance \$90 better.

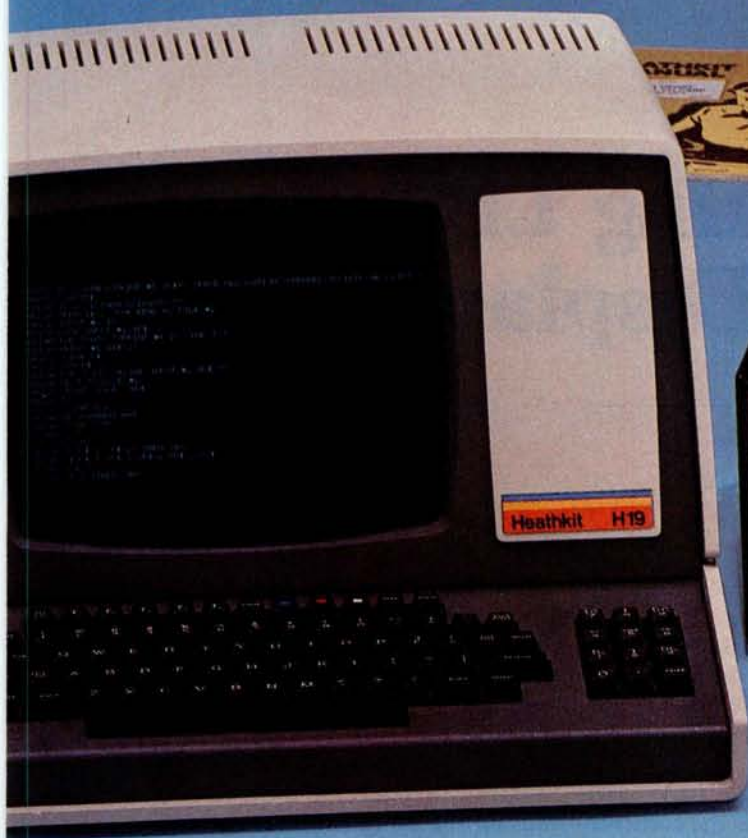

Circle 163 on inquiry card.

puters through the Heath User's Group (HUG). The experience of this computerite group can help you get the most from your computer.

Plus Heathkit service

You get the most thorough documentation ever written when you buy your Heathkit Computer. So it's easy to get your system assembled and operating quickly.

And you get one of the most reliable service organizations after you buy. More than 55 service locations throughout the U.S., plus a factory service phone give you fast access to experts when you need them.

It's all at your Heathkit Electronic Center

Computers, peripherals, software and accessories — in kit or assembled form — you'll find them all at your Heathkit Electronic Center. You'll even find educational support like

the special self-instruction programs that teach you BASIC and Assembly languages programming.

Check the white pages in the city nearest you for the location of your Heathkit Electronic Center*:

Alexandria, VA
Anaheim, CA
Atlanta, GA
Baltimore, MD
Boston, MA
Buffalo, NY
Chicago, IL
Cincinnati, OH
Cleveland, OH
Columbus, OH
Dallas, TX
Denver, CO
Detroit, MI
El Cerrito, CA
Fair Lawn, NJ
Frazier, PA
Hartford, CT
Houston, TX
Indianapolis, IN
Jericho, NY
Kansas City, KS
Los Angeles, CA
Louisville, KY
Miami, FL
Milwaukee, WI
Minneapolis, MN

New Orleans, LA
Norfolk, VA
Ocean, NJ
Oklahoma City, OK
Omaha, NB
Philadelphia, PA
Phoenix, AZ
Pittsburgh, PA
Pomona, CA
Providence, RI
Redwood, CA
Rochester, NY
Rockville, MD
Sacramento, CA
Salt Lake City, UT
San Antonio, TX
San Diego, CA
San Jose, CA
Seattle, WA
St. Louis, MO
St. Paul, MN
Tampa, FL
Toledo, OH
White Plains, NY
Woodland Hills, CA

FREE CATALOG

Write for a **FREE** Heathkit Catalog containing the complete line of Heathkit Computers, plus nearly 400 other electronic kits for your home, work or pleasure.

Heath Company, Dept. 334-580,
Benton Harbor, Mich. 49022



Heathkit

*Units of Schlumberger Products Corporation. Prices stated here are mail order and may be slightly higher at retail locations. CP-169

Self-Refreshing LED Graphics Display

Steve Ciarcia
POB 582
Glastonbury CT 06033

Light emitting diodes (LEDs) have been in use for a number of years. When first introduced they, like transistors, were very expensive, and were used only for special applications. Fortunately, manufacturing techniques have advanced to a point where a single red LED costs less than \$0.10. A further achievement is the availability of yellow, orange, and green LEDs.

When we think of graphics displays, we usually think of television-type video displays. All of the more popular personal computing systems have video displays, with the majority of them supporting graphics. It is not inconceivable that we will eventually see economical, flat, high-resolution LED displays which have the same capabilities as the current cathode ray tube displays. A manufacturing breakthrough will be required before this is a reality.

There have been some military programs requiring the construction of such displays. A few years ago, while still a member of the military-industrial complex, I worked on a bid to build a 10 by 10 foot LED display comprised of 792,000 discrete LEDs. My calculations at the time predicted that it would take about 3 kW of power to run.

This article is not going to describe how to replace your television screen

with a flat panel LED display, but will attempt something a bit more modest. The concept of LED graphics is not that far in the future. While we're waiting for technology to catch up with interest, we can experiment with the concept on a limited scale and analyze the various logic alternatives. A side benefit is the construction of an 8 by 16 LED display as your newest peripheral device.

Light Emitting Diode Displays

We all know about LEDs, correct? They are the little red things that glow when a current is passed through them. Most of us even remember to use a resistor to limit the average current to around 20 mA. What many people don't realize is that an LED can also be driven by much higher currents if *pulsed* on and off, rather than run continuously. This is a significant fact to keep in mind when building a large LED display.

Figure 1 shows standard methods for using transistor-transistor logic (TTL) to drive LEDs. The TTL gate can be used to either sink or source current to the LED without external transistors. In general, TTL devices will sink 16 thru 20 mA, while some go as high as 50 mA. (It's best to check manufacturer specification sheets if you are unsure.) Open col-

lector gates, shown in figures 1a and 1b, can be wired in either series or shunt configuration.

In figure 1a the circuit is completed and the LED is lit when a logic 1 is applied to the inverter input. The low-level output of the gate also provides a path to ground for the LED. Figure 1b, on the other hand, is a shunt circuit and exhibits an opposite logic. Normally current flow is through the LED, and it is lit. When a logic 1 is applied to the inverter, the resultant low output shunts the current to ground, shutting off the LED. There are advantages to both methods which I will discuss later.

Logic parts such as the 7400 NAND gate or 74LS04 inverter have active pull-up totem pole outputs. Rather than just a single NPN transistor like the open collector types, these have 2 transistors connected in series between the supply voltage V_{CC} and ground. Depending upon the logic state, only 1 of the 2 transistors will be conducting. Generally speaking, series and shunt LED drivers are more easily built with open collector devices. Figure 1d, however, cannot be accomplished with open collector logic, because this circuit depends upon the internal active pull-up resistance to source current to the LED. The exact amount of available current depends upon the logic type.

LOGIC TYPES	I _{OUT LOW}
74S \leq	20 mA
74H \leq	20 mA
74 \leq	16 mA
74LS \leq	8 mA
74L \leq	3.6 mA
CMOS	
4049 \geq	3 mA
CMOS	
4009 \geq	8 mA

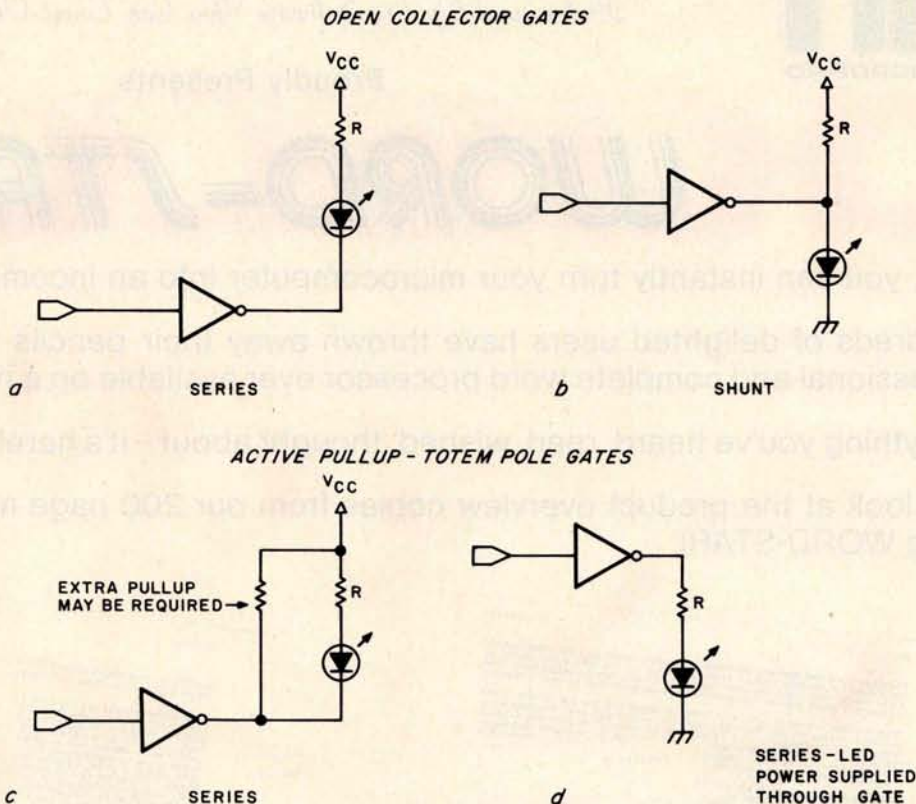

Figure 1: There are several ways of driving LED displays. A method employing a series circuit with an open collector gate turns on the LED when a logic 1 is applied to the inverter input. The shunt version of the open collector circuit turns on the LED when a logic 0 is applied to the inverter input.

If active pull-up totem-pole gates are used (the kind found in nearly all TTL gates), the circuits may be wired only in series. In figure 1c the voltage needed to power the LED comes from the supply voltage V_{CC} . In figure 1d the LED is wired in series, and the power to light the LED is supplied through the logic gate. Typical output currents are given for various types of logic in the accompanying table.

Returning to the discussion of displays using LEDs, it is quite simple to take the logic concepts of figure 1 and put them to use. Figure 2 outlines a simple 8-bit LED driver with latched

output. It is suitable as a bar-graph display, 8-level indicator, or 8-item annunciator. We always think first of using the video display to display the results of a logic decision, but if the

result is simply yes or no, the binary answer can be signified on an LED. In my own case, such an 8-bit display is used to keep track of enabled peripherals and I/O (input/output) channels.

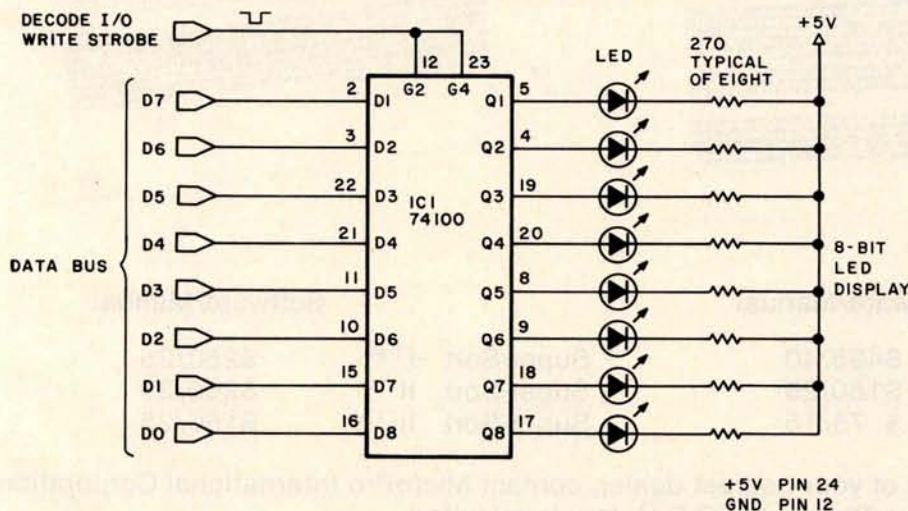
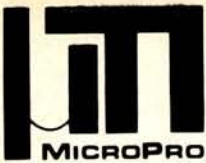

Figure 2: A simple 8-bit, latched-output LED display, suitable for use in computer-controlled bar graphs or 8-level indicators.

Larger LED Displays Have to Be Multiplexed

Using 8 LEDs probably doesn't excite too many people, especially when I started out with a number like 792,000. The 8 LEDs can, of course, be expanded to 64 by multiplying this same circuit 8-fold. With an average current of 15 mA for each LED and 100 mA for each 74100 dual 4-bit latch, the grand total to run it is slightly under 2 A at 5 V. This fact, and the necessity of having 64 resistors as well, leads us to consider some other means of driving the LEDs.

The logical alternative to continuous operation is time-multiplexed operation. For an LED with a 20 mA continuous current rating, this means



MicroPro International Corporation

"Professional Quality Software You Can Count On, Now!"

Proudly Presents

WORD-STAR T.M.

Now, you can instantly turn your microcomputer into an incomparable word processor.

Hundreds of delighted users have thrown away their pencils and are using the first truly professional and complete word processor ever available on a microcomputer, WORD-STAR.

Everything you've heard, read, wished, thought about - it's here! it's now! and it's Dynamite!!!

Just look at the product overview copies from our 200 page manual (prepared and printed using WORD-STAR).

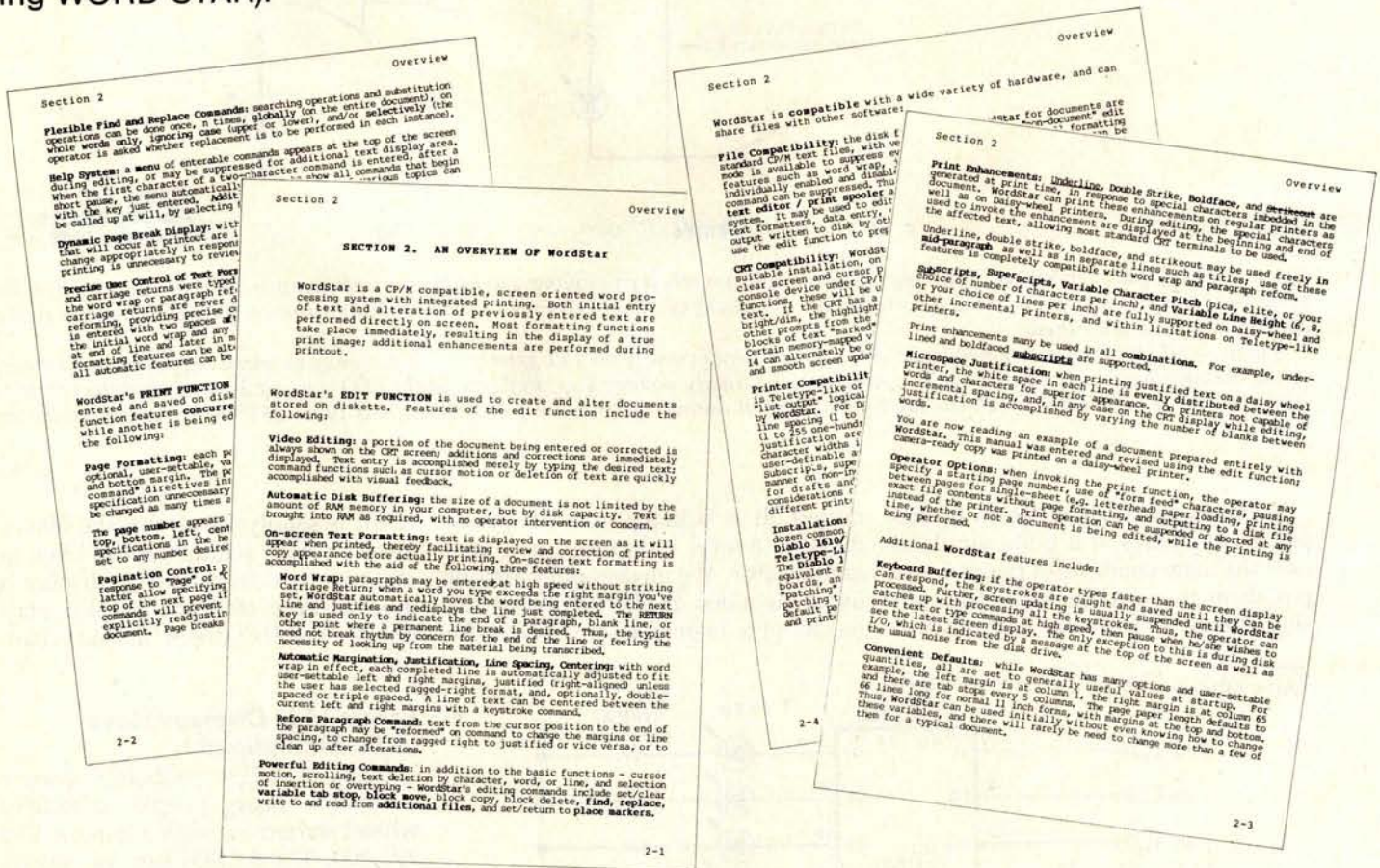

MicroPro Price List:

	Software/Manual	Software/Manual
Word-Star T.M.	\$495/40	Super-Sort I T.M. \$250/25
Word-Master T.M.	\$150/25	Super-Sort II T.M. \$200/25
Tex-Writer T.M.	\$ 75/15	Super-Sort III T.M. \$150/25

For more information and the name of your nearest dealer, contact MicroPro International Corporation. Dealer/Distributor/O.E.M. Inquires Invited

MICROPRO INTERNATIONAL CORPORATION
1299 4th Street, San Rafael, California 94901
Telephone (415) 457-8990 Telex 340388

17" x 22"
POSTER
AVAILABLE

The most complete, integrated, word processing software system ever seen on a microcomputer.

The logo for WordStar is centered in the advertisement. It features the words "WORD" and "STAR" in a stylized, blue, outlined font with a 3D effect. The letters are set against a bright orange, glowing, cloud-like background. This central graphic is surrounded by a dark blue field with numerous white, starburst-like rays emanating from behind the logo. The entire central composition is framed by a green border.

WORD
STAR

MicroPro International Corporation
"Professional quality software you can count on, now"



1299 Fourth Street, San Rafael, California 94901 • Telephone (415) 457-8990 • Telex 340388

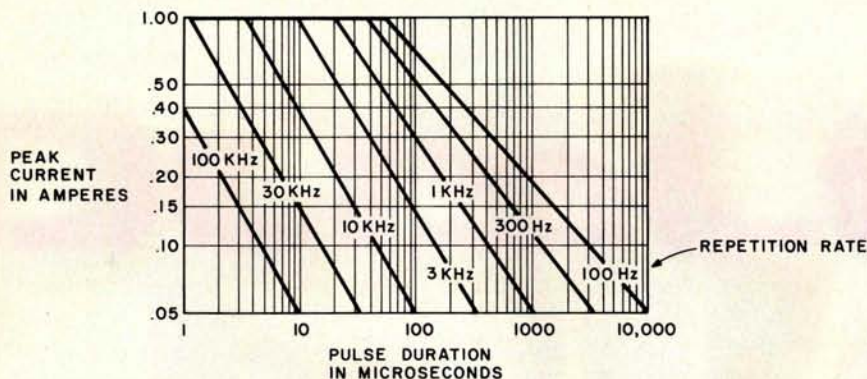

Figure 3: A typical curve for a T-1 3/4 LED showing the relationship between maximum current and pulse width for specified pulse rates.

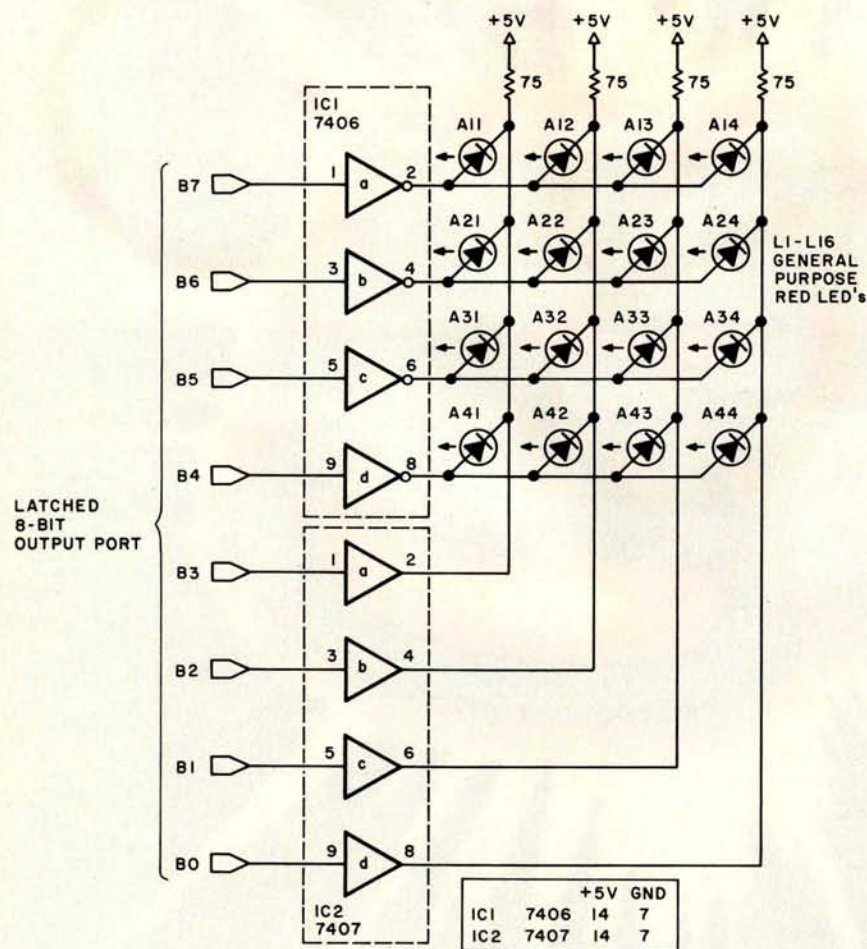

Figure 4: A simple 4 by 4 LED matrix which is software driven.

we'd raise the peak current (I_{pk}) and reduce the duty cycle. If the duty cycle were 25%, then 4 LEDs could be multiplexed through the same driver, and all would appear to operate continuously. The more LEDs in the loop, the lower the duty cycle. To maintain the same brightness, the current is raised again to produce a reasonable average current. It reaches

a point of diminishing returns when the duty cycle becomes so low that the peak current required to maintain a sufficient average current burns out the LED due to excessive power dissipation.

For pulsed applications, a curve of maximum peak current, pulse width, and repetition rate can be used to determine the maximum recom-

mended operating conditions. Figure 3 illustrates a typical curve for a T-1 3/4 LED such as that used in this article. It is determined by comparing peak and average junction temperatures during strobed operations, and maintaining a limit equivalent to the maximum allowable DC conditions. At any specified repetition rate, the relationship between maximum current and pulse width is shown. If, for example, 5 LEDs were to be multiplexed, and brightness maintained equivalent to a 10 mA continuous current, each would have to be pulsed for 1 ms 100 times a second, with a peak current of 100 mA.

Figure 4 shows a simple 4 by 4 LED matrix which demonstrates this concept. It also serves to point out some of the limitations of this bare-bones approach. A latched 8-bit parallel output port is all that is necessary to run this display. Four bits define the column and 4 bits define the row. Multiplexing is done in software.

To turn on the LED at location A22, bits B2 and B6 would be set to a logic 1, while lighting A43 would require a combination of bits B1 and B4. The logical process is essentially an extension of the shunt circuit described in figure 1.

A microprocessor can be used to control an X,Y addressable array of LEDs. The external circuitry required is minimal, and relatively little processor time is used to refresh the array. The technique used is to periodically strobe a row and column address into an output latch. At a predetermined later time, new information concerning the next display point is sent out to the latch. If this addressing can proceed faster than 100 times per second, then the entire display will appear to be DC driven. Usually, refresh timing is handled through interrupts.

There are important considerations to keep in mind when building this type of circuit. 7406 and 7407 inverting and noninverting drivers are not high current drivers, but they can sink 40 mA. They were chosen because they are cheap and available. If brightness is a problem and peak current has to be increased, these drivers can be replaced with transistors which have a higher current rating, or more gates of the same type can be added in parallel. The fact

Graphics for small systems were too expensive...

Circle 171 on inquiry card.

HIPLØT™ digital plotters

The perfect small system output device

- Displays data in easy to read graphical format
- Both serial and parallel inputs built-in
- Uses standard 8½" x 11" paper
- Plotting speed up to 2.4 ips
- Resolution of both 0.01 and 0.005 in.
- Baud rate and step size easily changed
- Completely assembled and ready to use
- Priced at \$1085*

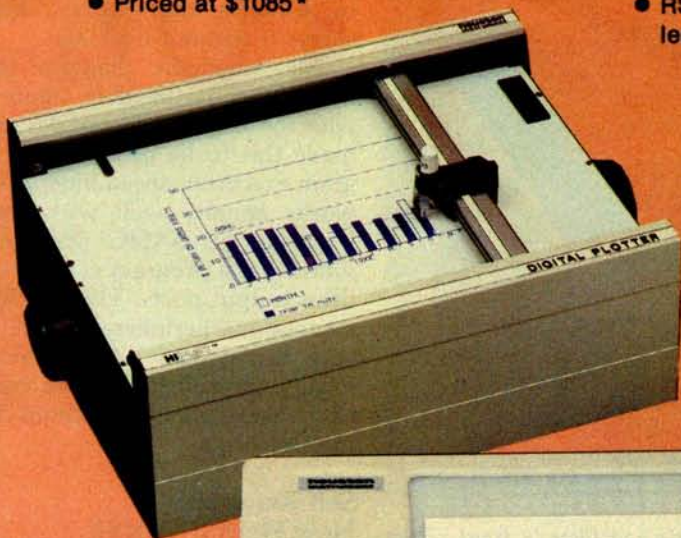

Circle 172 on inquiry card.

HIPAD™ digitizers

The perfect small system input device

- Resolution and repeatability of 0.005 in.
- Origin is completely relocatable
- RS232C and 8 bit parallel interface selectable at the connector
- Accuracies of ±0.015 in. (0.4mm)
 - Optional LC display shows actual values being inputted
 - Digitizing surface 11" x 11"
 - Priced at \$795*



(Optional LC display)

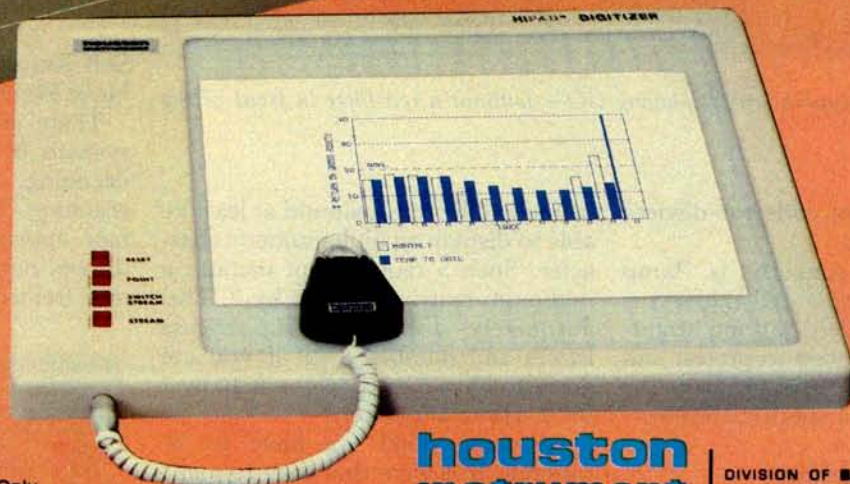

*U.S. Domestic Price Only
TM Trademark of Houston Instrument

For rush literature requests
or local sales office information only,
persons outside Texas call toll free 1-800-531-5205.

**houston
instrument**

DIVISION OF BAUSCH & LOMB

ONE HOUSTON SQUARE AUSTIN, TEXAS 78753
(512) 837-2820 TWX 910-881-2022

"the graphics - recorder company"

EUROPEAN OFFICE

Rochesterlaan 6 8240 Gistel Belgium
Phone 059/277445 Telex Bausch 81399

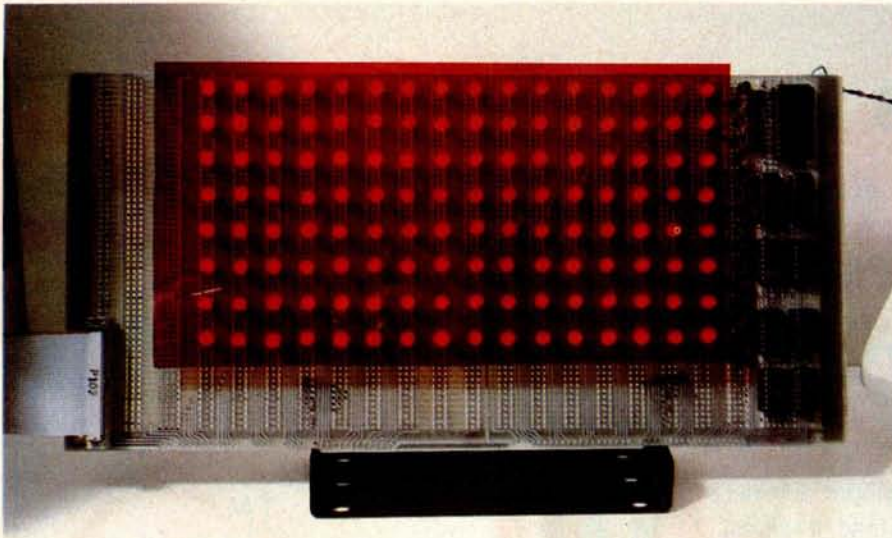

Photo 1: The prototype board for the light emitting diode (LED) display showing all of the LEDs turned on. A piece of red plastic is held in front of the display to increase visibility.

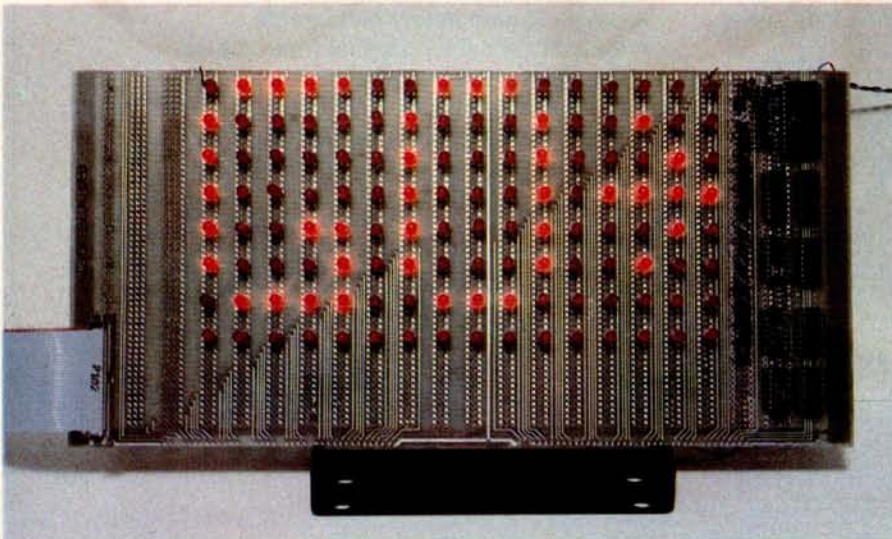

Photo 2: The prototype board displaying GO- without a red filter in front of the LEDs.

that they are open collector devices readily allows this.

The second concern is lamp brightness. LEDs operated at low currents can have widely varying brightness. It is a good idea to pretest and select LEDs which appear to have the same intensity at a specific current.

Build a Self-Refreshing LED Display

So far I've discussed arrays which, because of their size, have limited appeal and application. A 4 by 4 display is still in the realm of indicator, rather than information display panel. To

be really effective it should at least be able to display an alphanumeric character. Such a requirement dictates a minimum matrix size of 5 by 7. This adequately displays all upper-case letters and numbers. But if you are going to have 5 by 7, why not 10 by 7 for 2 letters and so on?

At some point we have to be rational. If it were that easy to make 200 by 200 LED arrays, someone would be making them now. In my case I needed a multipurpose flat panel display that could flash a message (even if only 1 letter at a time) and serve as a sophisticated

annunciator for my alarm system. The latter was the true reason for the use of LEDs.

A transparent sheet with an outline of my security system is placed over the LED array. Significant information is indicated by flashing the LED at the point within the array that corresponds to appropriate sensor activation. It is quite interesting to watch the approach of a car down the driveway as a series of LED indicators track it.

A 4 by 4 display was too low in resolution, and while a 5 by 7 display allowed ASCII alphanumeric displays, it was also a bit limited. Considering the hardware techniques employed and relative indifference to refresh considerations, I settled on an 8 by 16 display.

Photos 1 and 2 show the completed display prototype. The prototype consists of 128 red LEDs arranged in 16 columns of 8. Photo 1 illustrates them all lit. A red plastic filter is used to enhance the display. Photo 2 shows it without the filter.

The schematic diagram for this interface is outlined in figure 5. As with the majority of my designs, I've made this to be processor, and program execution-speed independent. It works equally well with assembly language or BASIC systems, provided that a program can directly address output ports. The interface is a stand-alone peripheral. Once loaded with display data, refresh operation is locally controlled, and the computer can even be shut off without disturbing the display.

Self-Refreshing— How Does It Work?

There are 3 major hardware subsystems in the 10-chip circuit: input decoding, data storage, and refresh scanning. To the computer, this interface appears as 16 output port addresses numbered 112 thru 127 decimal (remember BASIC uses decimal

Number	Type	+ 5 V	GND
IC1	7430	14	7
IC2	7404	14	7
IC3	74121	14	7
IC4	7489	16	8
IC5	7489	16	8
IC6	7406	14	7
IC7	7406	14	7
IC8	74157	16	8
IC9	7493	5	10
IC10	74154	24	12

Table 1: Power-wiring table for figure 5.



Apple lets you get personal with Pascal.

There's only one logical way to find out what a person wants in a personal computer.

Ask the person who'll be using one.

At Apple, we've been very successful at identifying just what people look for in computers. And then providing them with it.

In spades.

For serious enthusiasts, this means making available sophisticated innovations that are often conspicuously absent from other personal computers.

Like Pascal.

Apple II is one of the few personal computers that has it. And when you turn this

page and feast your eyes on the many advantages this high level, general-purpose language has to offer, you'll see why that's very good news indeed.



When you've got it, flaunt it.

If you'd like to let the world know who speaks Pascal, here's how:

Preheat iron (dry-wool setting) for 3 minutes. Slip garment on ironing board over scrap material. Remove wrinkles. Position transfer face down and pin edges to ironing board cover. Iron transfer slowly for one minute. If paper browns, iron is

too hot. Let transfer cool for one minute, then unpin and slowly pull transfer straight up. Results are best when t-shirt is at least 50% polyester.

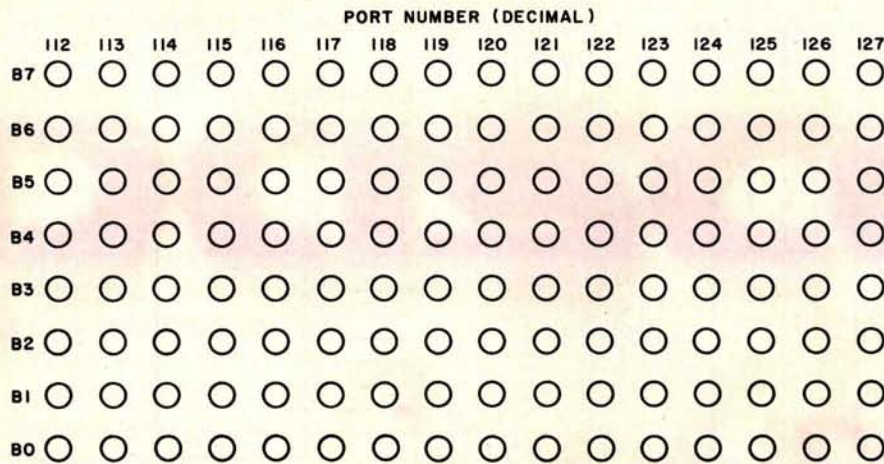

Figure 6: The 128 light emitting diodes (LEDs) are laid out in groups of 8. Each group of 8 is assigned to a consecutive output port. The port numbers are given here in decimal.

notation). Each column represents the 8 bits of that port.

The most significant bit (MSB) is at the top and the least significant bit (LSB) is at the bottom. The leftmost column is decoded as port number 112 and the rightmost is port number 127. This is depicted in detail in figure 6. These selections are arbitrary and can be any 16 successive port addresses you have available. These ports can also be memory mapped to use PEEK and POKE instructions

rather than input/output instructions, if you wish. (For further information on memory mapped I/O I refer you to the book *Ciarcia's Circuit Cellar* from BYTE Books.) ICs 1 and 2 decode these 16 addresses.

Integrated circuits IC3, IC4, IC5 and IC8 perform the data storage function. IC4 and IC5 are each 4-bit by 16-word programmable memory devices which together form an 8-bit by 16-word storage. When data is ready for display, the computer per-

forms an output procedure to the selected port. The entry-enable line goes low, selecting address bus lines A0 thru A3 to be applied as the address inputs to the 2 memory devices.

If port decimal 115 were selected in BASIC, the binary address would be 0011. Sections c and d of IC2 are included to forestall a potential race condition and serve to delay the firing of the one-shot monostable multivibrator IC3 until the propagation delay of ICs 4, 5, and 8 is satisfied. Once this port address is set through the 74157, the one-shot fires and writes the data present on the data bus into the memory. This is essentially the same sequence as any latched output port with the exception that 16 data bytes can be stored.

The schematic diagram as shown uses transistor-transistor logic (TTL) devices. If you have an S-100 system, or otherwise have limited bus driving capabilities, you may want to substitute low power TTL devices where necessary, or buffer all incoming lines.

The final area of significance is the LED refresh scanner. Figure 7 provides an expanded illustration. Rather than successively addressing 128 LEDs, resulting in a very low-

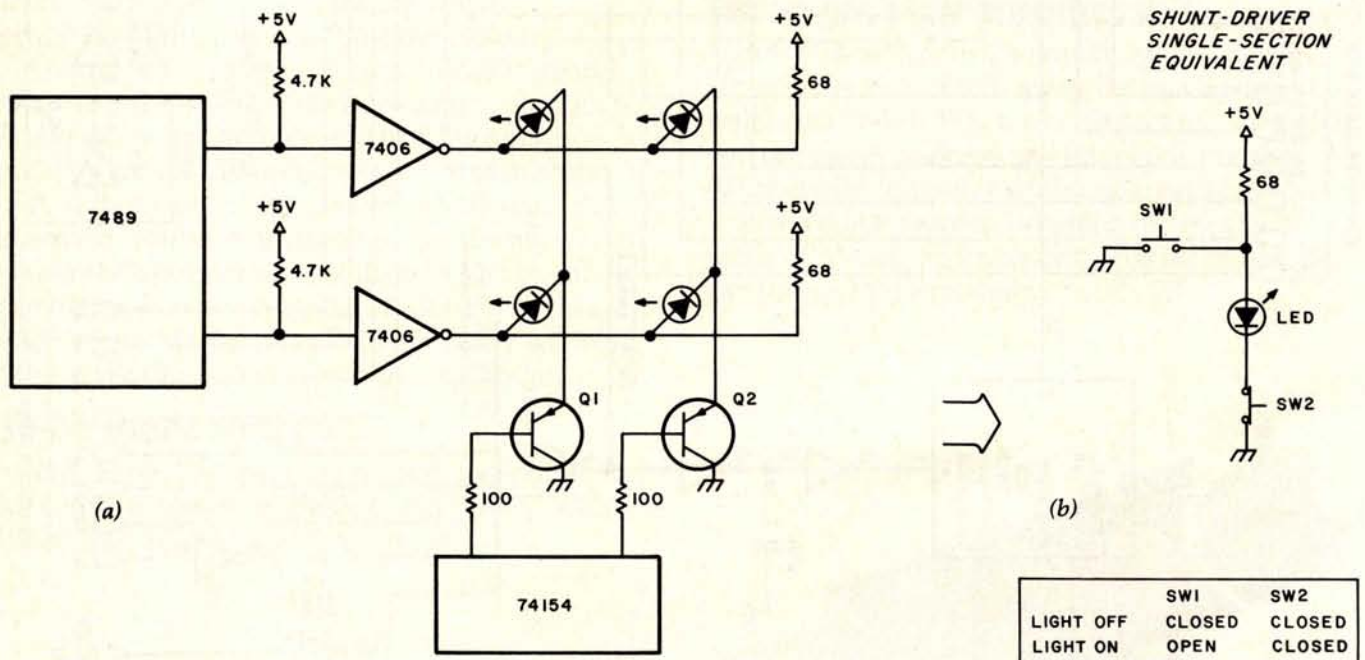

Figure 7: Expanded illustration of column scanning techniques used in self-refreshing LED graphics unit shown in figure 5. Each LED is not addressed sequentially; the LEDs are addressed by column. This results in a higher refresh rate and lower peak current to main-

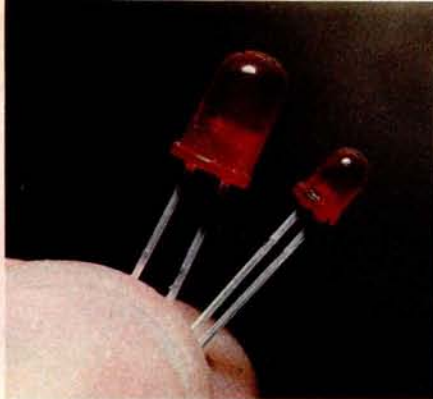

Photo 3: Two of the more popular red LEDs are the TIL-209 (the smaller LED) and the TIL-220 (larger LED). The average price for these devices is \$0.09 and \$0.11 apiece in quantity.

duty cycle, this design incorporates column scanning. Each light emitting diode (LED) is refreshed once every 16 clock pulses, rather than once every 128. The result is that lower peak current is required to maintain sufficient illumination.

When no data is being written into the memory (ICs 4 and 5), the address multiplexer is in the display mode. In this case it continually channels the output of a 4-bit free-running counter (IC9) to the memory address input. IC10 also receives this address and enables the particular column to which the data pertains.

In a normal sequence, the first address is 0000 binary. Since the memory is in a read condition, the output will reflect the data contents which had been stored previously as an output to port 112. IC10, a 4 to 16 demultiplexer, enables the first line by bringing it to a logic 0. The shunt drivers now enabled will allow any LED in that column to turn on in response to a stored logic 1 on that bit position. The only LEDs that can light at this time are in the first column.

The circuit will stay on this address until the next clock pulse from ICs 2a and 2b. The next address would enable the next column with similar results. The scan oscillator should be fast enough that the display does not flicker.

Various LEDs can be used. Probably the most popular size is the T-1 $\frac{3}{4}$ (such as the Texas Instruments TIL-220) made by most LED manufacturers and priced at about \$0.11. If space is a problem, a smaller T-1 can be used with cost at about \$0.09. Their relative sizes are shown in photo 3.

There is nothing which requires that the display be monochromatic. Considering that color television screens are actually discrete dots which seem to blend together when viewed from a distance, this same possibility is open for use with LEDs to a limited extent. The 3 LEDs can be mounted quite closely as demonstrated in photo 4. Experimenting with the tricolor system produced some interesting results. You must realize, of course, that a 3-color display would require 3 sets of digital logic equivalent to the circuit of figure 5.

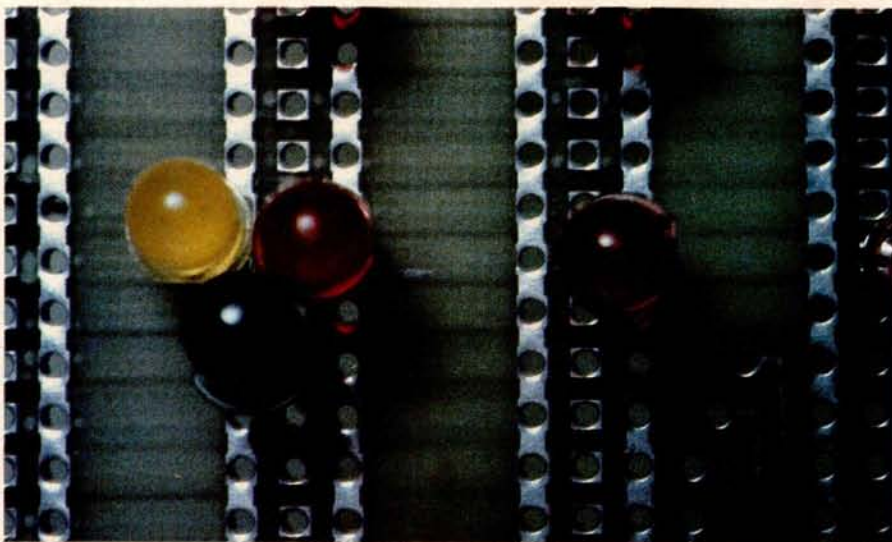

Photo 4: To experiment with 3-color displays, 3 LEDs must be placed in each position on the board.



Photo 5: The program in listing 2 produces the display shown here.

Using a Flat Panel Display

The first thing to do after powering up and checking out the circuitry is to try to write data to it. Listing 1 is a BASIC program which sequentially exercises all 128 LEDs. Erroneous data entry can usually be traced to a too long pulse width on the one-shot (IC3).

Once the arrays have been built, you are ready for the big time— displaying a 5 by 7 dot-matrix character. Photo 5 illustrates this final achievement, and listing 2 shows the simple BASIC program required to accomplish this.

Listing 1: BASIC program to turn each light emitting diode (LED) on and off in order.

```
100 REM THIS PROGRAM CHECKS EVERY LED INDIVIDUALLY
110 REM BY OUTPUTTING A SERIES OF COMPUTED VALUES TO THE
120 REM APPROPRIATE OUTPUT PORT
130 REM
140 REM 8X16 DISPLAY IS ADDRESSED AS 16 PORTS - NO.S 112 TO 127 DECIMAL
150 REM WITH LSD ON THE LEFT AND MSD ON THE RIGHT
160 REM
170 REM FIRST THE DISPLAY IS BLANKED BY OUTPUTTING ALL ZEROS
180 FOR S=112 TO 127
190 OUT S,0
200 NEXT S
210 REM
220 REM STARTING FROM THE LOWER LEFT CORNER LEDS ARE PROGRESSIVELY LIT
230 REM UP AND DOWN THE COLUMNS MOVING TOWARD THE RIGHT
240 FOR I=112 TO 127
250 FOR B=0 TO 7
260 A=2^B
270 OUT I,A
280 GOSUB 1000
290 NEXT B
300 OUT I,0
310 NEXT I
320 GOTO 240
1000 FOR T=0 TO 50
1010 NEXT T
1020 RETURN
```

Listing 2: BASIC program to write GO— on the LED display.

```
100 REM THIS PROGRAM WRITES GO > ON THE DISPLAY
110 REM USING DATA STATEMENTS TO ENTER MATRIX DATA
120 DIM X(100):DIM S(100)
130 DATA 124,130,130,138,142,0
140 DATA 124,130,130,130,124,0
150 DATA 16,84,56,16
160 FOR S=1 TO 16
170 READ X(S)
180 NEXT S
190 FOR C=112 TO 127
200 OUT C,X(C-111)
210 NEXT C
220 STOP :GOTO 190
```

Static displays are interesting, but if you really want to do a little crowd-pleasing, then I suggest simulating a moving marquee. Because this display interface is column-oriented, it is relatively simple to accomplish this feat. Listing 3 is a program for shifting the letter A across the display.

The character is left-justified when first displayed with the 5 by 7 data written in ports 112 thru 116. On the next programmed update, the same data is written to ports 113 thru 117,

TUNE-UP YOUR PET®...\$109.95 with enclosure \$134.95

- Exact Pet keyboard layout
- Double-shot keytops with graphics legends
- Duplicate Return, Space and Shift keys on numeric pad for programming ease
- Added function key which can be hard wired as a system reset
- Flexible cable and connector supplied



* TM of Commodore Business Machines, Inc.

Century Research & Marketing, Inc.
4815 W. 77th St.
Mpls., MN 55435

Erhardt & Jost Electronics
Rossligasse 2
CH 4450 Sissach
Switzerland

Listing 3: BASIC program to move the letter A across the display from left to right.

```

100 REM THIS PROGRAM DEMONSTRATES USING THE DISPLAY PANEL AS A MOVING MARQUEE
110 REM A 5X7 DOT MATRIX LETTER A IS DISPLAYED ON THE LEFT SIDE
120 REM AND THE SHIFTED ACROSS THE DISPLAY TO THE RIGHT, USING THIS CONCEPT
130 REM VIRTUALLY ANY MESSAGE CAN BE WRITTEN.
140 DIM A(100) :DIM S(20) :DIM X(100)
150 REM FIRST THE LETTER A IS LEFT JUSTIFIED ON THE DISPLAY
160 A(1)=254 :A(2)=144 :A(3)=144 :A(4)=144 :A(5)=254 :REM A(1)-A(5) EQUAL THE LETTER A
170 FOR Q=6 TO 20 :A(Q)=0 :NEXT Q
180 REM
190 REM
200 REM CLEAR THE DISPLAY
210 FOR L=112 TO 127 :OUT L,0 :NEXT L
220 REM
230 REM
240 REM DEFINE TRANSPOSED MATRIX X(1) TO X(16) AND SHIFT RIGHT ONE COLUMN
250 S=1
260 FOR D=1 TO 16
270 X(D)=A(S)
280 S=S+1
290 IF S>20 THEN S=1
300 NEXT D
310 S=S+3
320 GOSUB 370
330 GOTO 260
340 REM
350 REM
360 REM WRITE TRANSPOSED MATRIX TO DISPLAY
370 FOR L=112 TO 127
380 OUT L,X(L-111)
390 NEXT L
400 FOR T=0 TO 300 :NEXT T :RETURN
410 RETURN

```

effectively shifting it to the right by 1 column. For long messages, the most effective method is to utilize a software pointer. Even a 2½ character moving marquee is very impressive and can easily convey intelligent information.

This 8 by 16 matrix can be expanded by adding more memory and column decoders. It can be further

enhanced by the addition of other colors within the same array.

The video screen need not be the only output display on a personal computer. It is only a matter of time before large arrays are commercially available, but in the meantime we can experiment with the concept. I hope that by presenting a self-refreshing interface design which eliminates the

necessity of interrupts or dedicated program refresh, I may spark the interest of many experimenters.

If you have any questions on this or any previous article, don't hesitate to write to me. Please include a self-addressed stamped envelope. ■

Next Month: A look at the new Intel 8086.



8086 Boards

CPU with Vectored Interrupts \$650.
 PROM-I/O \$495.
 RAM 8K x 16/16K x 8 \$395.

ANALOG Boards

A/D 16 Channel, \$495.
 12 Bit, High Speed
 D/A 4 Channel, \$395.
 12 Bit, High Speed



VIDEO DIGITIZATION

Real Time Video Digitizer and Display System \$850.
 Computer Portrait System \$4950.

S-100 Boards

Video and/or Analog Data Acquisition Microcomputer Systems



The High Performance S-100 People
TECMAR, INC.
 23414 Greenlawn • Cleveland, OH 44122
 (216) 382-7599

Using Finite State Machines

David E Cortesi, 2340 Tasso St, Palo Alto CA 94301

I was pleased to see a good introductory article on the use of finite state machines appear in BYTE (see "Designing a Command Language" by G A Van den Bout, BYTE, June 1979, page 176). I have found the finite state machine (or finite state automaton, or just FSA) to be a valuable tool in my programmer's toolkit. The finite state machine is an aid to organizing one's thoughts while designing, a good way of producing a really unambiguous specification document, and as an implemented program it can yield very efficient and reliable code.

The finite state machine has long been a plaything of the theoreticians of computer science; you can find it described and analyzed in any textbook on compiler design (it is a *good* textbook if you can understand the description!). Unfortunately the finite state machine rarely moves out of the textbook and into practical programs. I would like to extend Van den Bout's article with 2 examples from my own experience as a professional programmer that show how the finite state machine solved difficult programming problems in the real world.

The first case arose during the design of a timesharing system that was to have a large number of commands. The syntax of the command language was laid down early in the project, but the specification of the commands themselves kept changing. If I and my colleagues had tried to write detailed code to parse each of the many commands and operands, especially in the face of changing specifications, we would have been swamped. We had to do something to systematize the command-parsing code.

We hit on the idea of using finite state machines represented as directed graphs (like the figures in the previous BYTE article). Since we were using a macro-assembler, we created NODE and ARC macroinstructions so that we could "draw" the graph of a command by writing a series of macro calls. Listing 1 shows how some of the chess game commands in the prior article might look in such a macrolanguage.

Each macroinstruction assembled to a small group of constants. We thought of these groups as the machine language of an imaginary finite state computer. We then wrote a finite state interpreter which could process these machine instructions. This interpreter program took as its input: (1) the top node of a graph; (2) the tokenized command line from the user; and (3) a small working storage area where semantic routines could leave their

```

S1 ANODE ; TOP NODE, ARCS SELECT VERB-TOKENS
   ARC TOKEN=KWD,VALUE='MOVE',NEXT=S2M
   ARC TOKEN=KWD,VALUE='CAP',NEXT=S2C
   ARC TOKEN=KWD,VALUE='TAKE',NEXT=S11
   ZNODE 'MOVE, CAP, OR TAKE??'
S2M ANODE VERB=1 ; SET VERB-CODE OF MOVE
   ARC TOKEN=ANY,NEXT=S2
S2C ANODE VERB=2 ; SET VERB-CODE OF CAP
   ; COMMON GRAPH FOR MOVE AND CAP
S2 ANODE
   ARC TOKEN=KWD,VALUE='FROM',NEXT=S3
   ARC TOKEN=KWD,VALUE='TO',NEXT=S8
   ZNODE '?? PLEASE SAY TO OR FROM'
   ; GRAPH OF 'FROM XX TO YY' PART
S3 ANODE
   ARC TOKEN=POS,SEMACT=FRPOS,NEXT=S4
   ZNODE 'A POSITION MUST FOLLOW FROM'
S4 ANODE
   ARC TOKEN=KWD,VALUE='TO',NEXT=S5
   ZNODE 'FROM XX -- EXPECTING TO'
S5 ANODE
   ARC TOKEN=POS,SEMACT=TOPOS,NEXT=S6
   ZNODE 'A POSITION MUST FOLLOW TO'
   ; GRAPH OF 'TO XX FROM YY' VARIANT
S8 ANODE
   ARC TOKEN=POS,SEMACT=TOPOS,NEXT=S9
   ZNODE 'A POSITION MUST FOLLOW TO'
S9 ANODE
   ARC TOKEN=KWD,VALUE='FROM',NEXT=S10
   ZNODE 'TO XX -- EXPECTING FROM'
S10 ANODE
   ARC TOKEN=POS,SEMACT=FRPOS,NEXT=S6
   ZNODE 'A POSITION MUST FOLLOW FROM'
   ; END-CHECK FOR MOVE AND CAP
S6 ANODE
   ARC TOKEN=END ; OMITTED NEXT= MEANS 'ALL DONE'
   ZNODE 'EXTRA OPERAND'
S11 ANODE VERB=3 ; SET VERB-CODE OF TAKE
... etc, etc, etc.

```

Listing 1: A graph representation of a finite state machine as it might look drawn with a macro-assembler. The macro-instructions would assemble to machine language for a hypothetical finite state computer; that in turn would be simulated by an interpreter.

R W	INPUT TOKEN						
	+	-	0	1...9	.	E	<end>
1	2/A0	2/A1	3/A0	4/A2	5/A3	0/E1	0/E2
2	0/E3	0/E3	3/A0	4/A2	5/A3	0/E4	0/E5
3	0/E6	0/E6	3/A0	4/A2	5/A3	6/A4	0/Z1
4	0/E7	0/E7	4/A2	4/A2	5/A3	6/A4	0/Z2
5	0/E8	0/E8	5/A5	5/A5	0/E9	6/A4	0/Z3
6	7/A0	7/A6	7/A0	7/A7	0/E10	0/E11	0/E12
7	0/E13	0/E13	7/A7	7/A7	0/E10	0/E11	0/Z4

```

A0: do nothing
A1: note negative
A2: collect integer digit
A3: note rational
A4: note exponential
A5: collect fraction digit
A6: note negative exponent
A7: collect exponent digit
Z1: exit, value is zero
Z2: exit, value is integral
Z3: exit for rational
Z4: exit for exponential
E1: number(?) is <E>..
E2: number is null
E3: <sign><sign>...
E4: <sign><E>..
E5: <sign><end>
E6: 0..<sign>..
E7: <digit>..<sign>..
E8: ..<decimal><sign>..
E9: ..<decimal><decimal>..
E10: ..<E><decimal>..
E11: ..<E><E>..
E12: ..<e><end>
E13: ..<E><sign><sign>..

```

Table 1: A finite state machine for processing numeric constants, represented as an array. Each row is a state of the machine; a column is selected by the next input token. At the intersection is the row number for the next step, and the name of an action to be done.

TARBELL VDS-II

Vertical Disk Subsystem

SYSTEM INCLUDES:

- 2 Siemens 8" Disk Drives
- 1 Cabinet with Fan and Power Supply.
- 1 Tarbell Floppy Disk Interface, assembled & tested.
- 1 CP/M Disk Operating System.
- 1 Tarbell BASIC.
- All Cables and Connectors.
- Complete User Documentation.
- Fully factory assembled and tested.

Price \$1888.00



Tarbell
Electronics

950 DOVLEN PLACE • SUITE B • CARSON, CALIFORNIA 90746
(213) 538-4251 • (213) 538-2254

output. It returned either a verb number (from an ANODE macroinstruction) or an error message (from a ZNODE macroinstruction). The only other code needed was a set of small, easily coded semantic routines, one to convert and store away each kind of token.

With this mechanism in place we had only to "draw" each command's graph in macroinstructions, and add any semantic routines unique to that command. The job was much smaller than writing code for all commands, and far easier to update as the specifications fluctuated. The same interpreter was used again in a later project with a similar command language.

This method of writing a command language turned out to have an advantage we had not expected. Every time we wrote a ZNODE macroinstruction, we were faced with the fact that someday a user would enter a bad command that would drop through to that ZNODE. Each time we were forced to decide what the system should do when that occurred. Every possible user error was made evident to us and we had to think about error responses in more detail than usual, but the very specific circumstances under which each error was trapped made it easy to give explicit, helpful messages.

The second example comes from the construction of an interpreter for a programming language. An interpreter has to do a lot of converting between the character form of numbers and their internal form (binary, in this case). The language being implemented supported every form of numeric constant, including things like

```
1.      (for a real 1.0)
3E25   (decimal not required)
+00319645.26E-0005 (leading zeroes, signs)
```

When I was presented with this problem I had just completed a course in compiler writing, where I had seen finite state machines applied to exactly this problem. It took but a day to work out an array like that in table 1. This is a finite state machine, but one represented as an array instead of a graph. The 2 representations are equivalent; a finite state machine drawn as a graph can be drawn as an array or vice versa. The nodes of the graph become the rows of the array; the lines become columns.

The array is processed like this: the finite state machine is always active on some row, initially row 1. Get the next input token. Find the column with that token at its head (of course a clever designer will have arranged that a token is just an integer that is a valid column-index). At the intersection of that column and the active row, find 2 items, such as 2/A1. The first item, like 2, becomes the new active row. The second item, like A1, is the label of a semantic action to be performed. Repeat until the active row number is 0, then stop.

Look at row 1 of table 1. Reading across, if the first token of a numeric constant is:

```
+ do nothing and go to row 2
- remember to negate the result and go to row 2
0 do nothing and go to row 3
1...9 collect a digit and go to row 4
. note the number will be rational ("real") and go to
  row 5
E error — number starts with E, stop
<end> error, stop
```

If you read the other rows the same way, you will see how this finite state machine can parse any legitimate numeric constant. It also finds every possible syntax error in a very explicit way.

So far I had not gone beyond what any textbook could tell me, but I had the additional objective of making the fastest assembler language constant converter that I could. I wanted to use every hardware advantage allowed by my machine, yet keep reliable, readable code — and the finite state machine helped me!

I eventually ended up with an array several rows higher than the one in table 1. Each additional row was designed to pick up a particular set of input characteristics that I could take advantage of. One optimization was row 3 of table 1, which does not appear in most textbooks. The finite state machine stays on row 3 as long as it is seeing leading zeroes on the integer part of the number. Action A2, "collect integer digit," will typically involve performing arithmetic operations on the token. A leading zero contributes nothing to the final binary value, so why "collect" it? The finite state machine stays on row 3, spinning through the leading zeroes and doing almost no work, until a significant digit is found. If the finite state machine takes exit action Z1, it has recognized a constant of zero (fairly common in programs) without doing any arithmetic.

We expected single-digit constants to be quite common in typical programs. It happened that the binary value of a single digit could be obtained from the input token with a logical AND operation. I put in another row between rows 3 and 4 of table 1, so that a special exit action would be taken for the case of <digit> <end>. Now the finite state machine would process any single-digit constant without doing arithmetic. These and other hardware-level optimizations were achieved during design; they added almost nothing to the complexity of the final code.

The array form of a finite state machine is easily coded using a pair of integer matrices, one for the next-state numbers and one for the action-numbers (action-labels, if your language allows label variables; action-addresses in assembler language). The resulting program almost has to be smaller and more readable than the brute force code needed to do the same job. Since the act of designing the array forces you to consider every possible input sequence, the program will usually be much more reliable.

I have drawn these examples from professional software projects, but those are certainly not the only places where finite state machines can be used. I hope I have shown that the finite state machine can be a valuable tool for anyone faced with programming for a complicated input string. Designing it clarifies the problem and reveals all error situations, and coding it yields elegant, efficient programs. ■

Technical Forum is a feature intended as an interactive dialog on the technology of personal computing. The subject matter is open-ended, and the intent is to foster discussion and communication among readers of BYTE. We ask that all correspondents supply their full names and addresses to be printed with their commentaries. We also ask that correspondents supply their telephone numbers, which will not be printed.

6502 GAMES

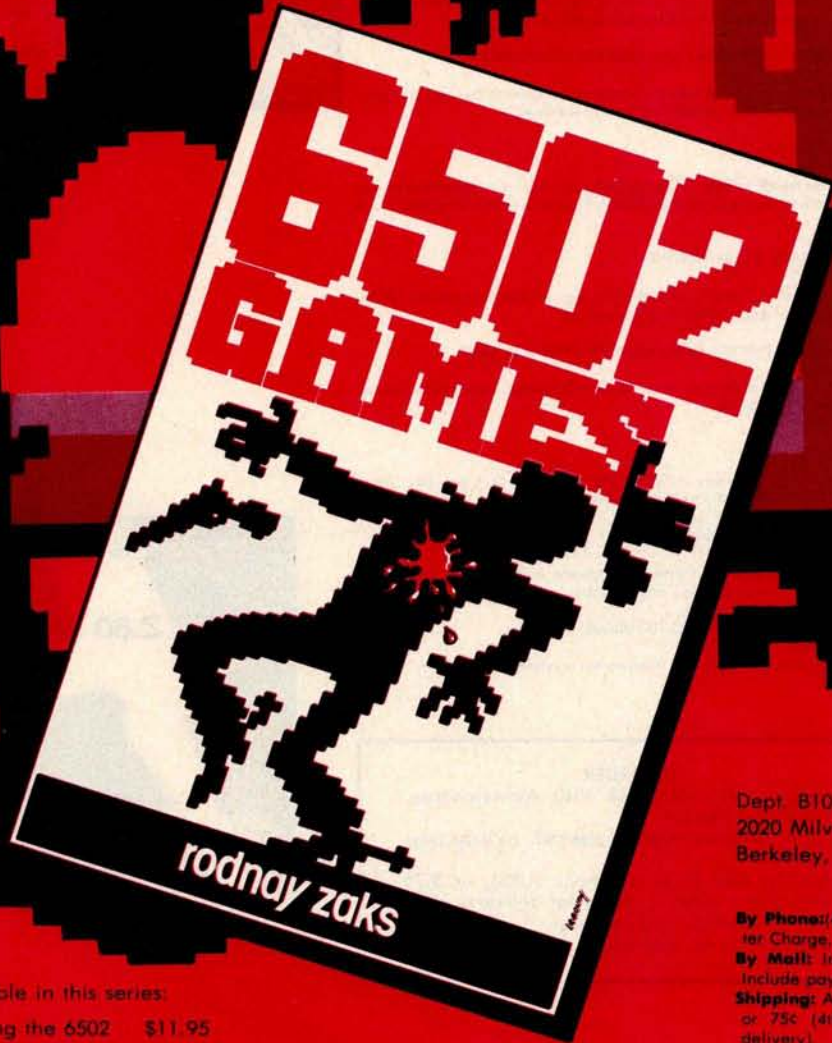

Play games with the 6502...magic squares, mindbender, blackjack, music, echo, tic tac toe, spinner, translate, slots and hexguess. Each may be implemented in less than 1K of RAM, and all listings are given in 6502 assembly language and hexadecimal.

Rodnay Zaks
Ref. G402, 200 pp. \$12.95

Also available in this series:
Programming the 6502 \$11.95
6502 Applications Book \$12.95

Circle 349 on inquiry card.



Dept. B10
2020 Milvia Street
Berkeley, California 94704

TO ORDER

By Phone: (415) 848-8233. Visa, MasterCard, American Express.
By Mail: Indicate quantity desired. Include payment.
Shipping: Add \$1.50 per book (UPS), or 75¢ (4th class—allow 4 weeks delivery).
Tax: in California add tax.
BYTE October 1979 73

LET SYBEX SH

The **SYBEX** self-study course library features ten professional quality audio recordings of lectures on a variety of microprocessor topics, from the introductory to the advanced levels. Widely used in academic and industrial training environments, each course is accompanied by a specially prepared seminar workbook.

SYBEX courses are the result of our extensive experience combining state-of-the-art technical information with thoroughly planned instructional programming techniques.

INTRODUCTION TO MICROPROCESSORS

Reference #S1

This seminar is intended for all nonspecialists who wish to acquire a broad understanding of the basic concepts and advantages of microprocessors.

PROGRAMMING MICROPROCESSORS

Reference #S2

This seminar describes the internal operation of a microprocessor system including how instructions are fetched and executed as well as how programs are written and executed in typical cases (arithmetic and input/output).

DESIGNING A MICROPROCESSOR SYSTEM

Reference #S3

How to interconnect a standard microprocessor system in detail: the ROM, RAM, PIO, UART, MPU, clock. Trade-offs in addressing techniques.

INTRODUCTION TO PERSONAL AND BUSINESS COMPUTING

Reference #S10B

Are you planning to buy or use a microcomputer system? This seminar enables you to understand the choices and possibilities.

INTRODUCTION TO PERSONAL AND BUSINESS COMPUTING

Reference #S10B

Are you planning to buy or use a microcomputer system? This seminar gives you an understanding of the choices and possibilities.

MICROPROCESSORS

Reference #SB1

The basic hardware course. It will provide you with a comprehensive and effective understanding of all the important aspects of microprocessors and systems.

MICROPROCESSOR PROGRAMMING

Reference #SB2

The basic software course. It will take you step by step through all the important aspects of microcomputer programming.

MILITARY (SEVERE ENVIRONMENT) MICROPROCESSOR SYSTEMS

Reference #SB3

A complete study of constraints, techniques, and systems available for severe-environment applications.

BIT-SLICE

Reference #SB5

A complete detailed system, including bits, can be built in one day. Other innovative applications of slices are also examined.

INDUSTRIAL MICROPROCESSOR SYSTEMS

Reference #SB6

This course stresses actual industrial hardware and software techniques: the components, the programs, and the costs.

MICROPROCESSOR INTERFACING TECHNIQUES

Reference #SB7

How to assemble, interface and interconnect a system.

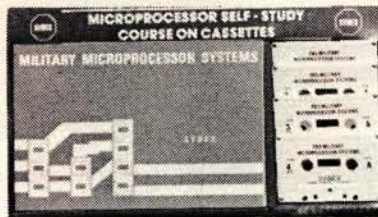
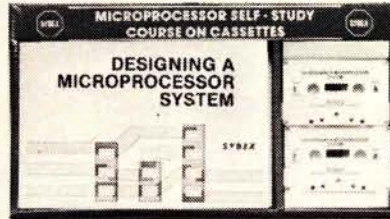
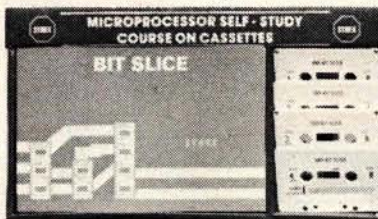
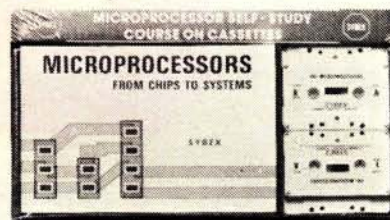

TO ORDER:

By Phone: (415) 848-8233. Visa, Mastercharge, American Express.

By Mail: Indicate quantity desired. Include payment.

Shipping: Add \$1.50 per book (UPS), or \$.75 (4th class - allow 4 weeks for delivery); double for cassettes and overseas.

Tax: In California add tax.

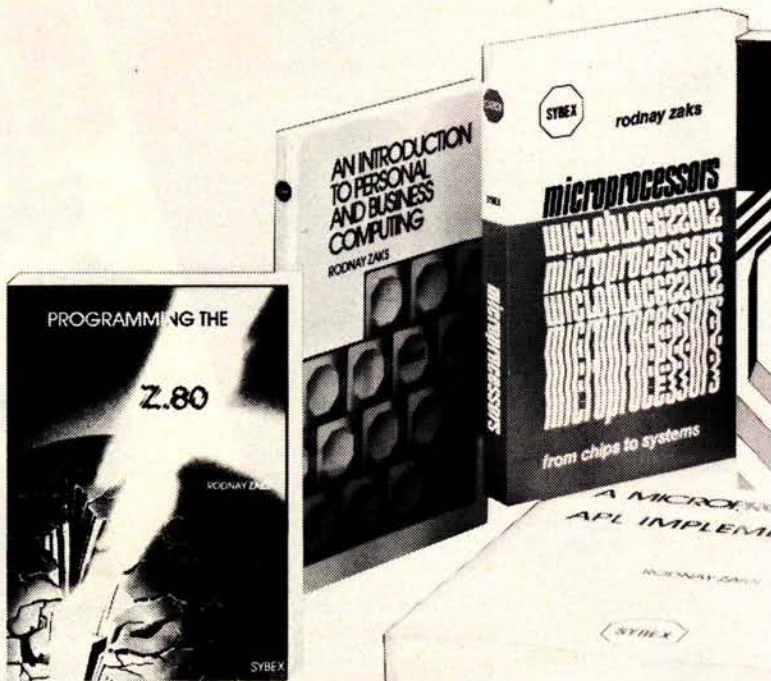

OW YOU HOW

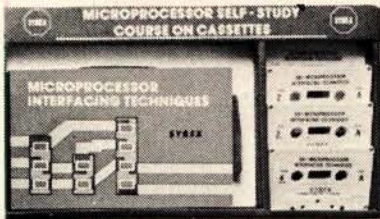

SYBEX books offer a comprehensive overview of microprocessors from beginning to advanced levels. Programming techniques, interfacing and implementation are thoroughly presented and analyzed in a highly readable and informative style, while providing the reader a detailed understanding of various computer systems.

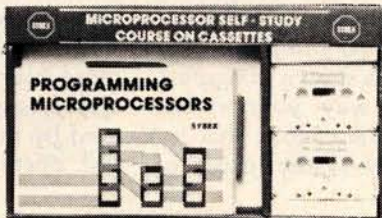
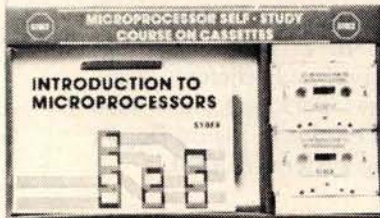
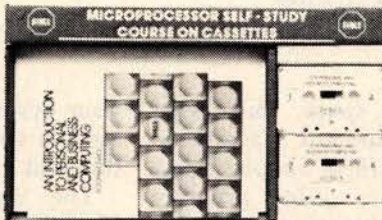
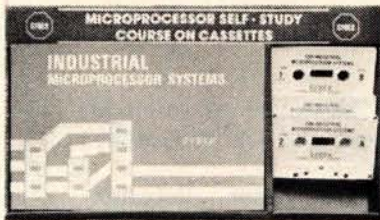

PROGRAMMING THE Z80
Reference #C280
RODNAY ZAKS, 330 pages
A complete introductory text for the Z80.

AN INTRODUCTION TO PERSONAL AND BUSINESS COMPUTING
Reference #C200
RODNAY ZAKS, 250 pages
A comprehensive introduction to small computers, their peripherals, and what to select.

MICROPROCESSORS: FROM CHIPS TO SYSTEMS
Reference #C201
RODNAY ZAKS, 416 pages
The basic text on all aspects of microprocessors and the assembly of a system.

PROGRAMMING THE 6502
Reference #C202
RODNAY ZAKS, 400 pages
A complete introductory programming text for the 6502.

6502 APPLICATIONS BOOK
Reference #D302
RODNAY ZAKS, 288 pages
Connecting a 6502 board to the outside world: from home alarm to music and industrial control.

MICROPROGRAMMED APL IMPLEMENTATION
Reference #Z10
RODNAY ZAKS, 350 pages
Presents a uniform conceptual analysis of the parsing and interpreting process for APL, as well as the actual implementation techniques.

MICROPROCESSOR INTERFACING TECHNIQUES
Reference #C207
AUSTIN LESEA & RODNAY ZAKS, 416 pages
How to interface a microprocessor to external devices: from keyboard to ADC to floppy disk, including standard busses.

MICROPROCESSOR LEXICON
Reference #X1
All the definitions of the microprocessor world in a convenient pocketbook format.

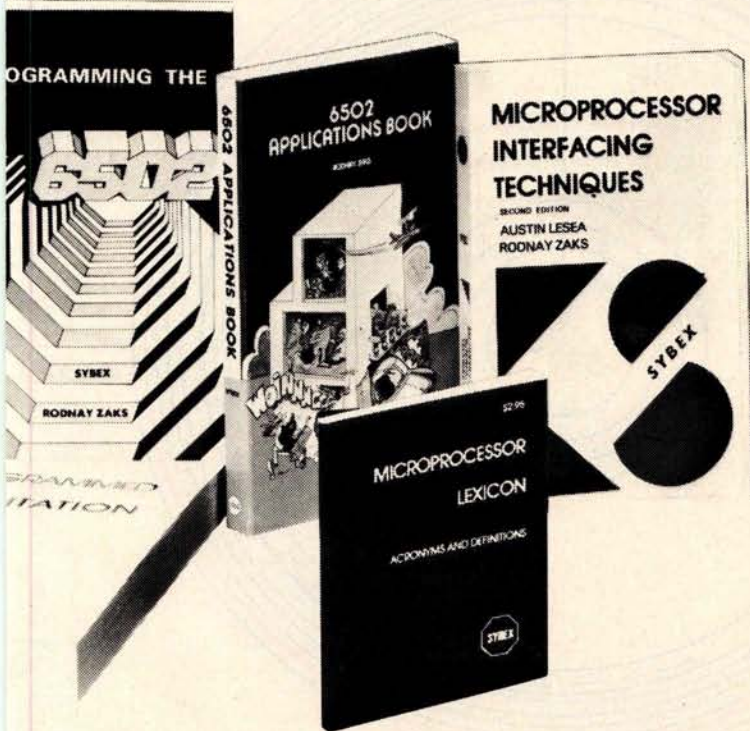

SYBEX
Dept.
2020 Milvia Street
Berkeley, California 94704

<input type="checkbox"/> S10B	\$21.90	<input type="checkbox"/> S1	\$19.95
<input type="checkbox"/> C280	\$11.95	<input type="checkbox"/> S2	\$29.95
<input type="checkbox"/> C200	\$6.95	<input type="checkbox"/> S3	\$29.95
<input type="checkbox"/> C201	\$10.95	<input type="checkbox"/> SB1	\$69.95
<input type="checkbox"/> C202	\$11.95	<input type="checkbox"/> SB2	\$69.95
<input type="checkbox"/> D302	\$12.95	<input type="checkbox"/> SB3	\$59.95
<input type="checkbox"/> Z10	\$25.00	<input type="checkbox"/> SB5	\$59.95
<input type="checkbox"/> C207	\$13.95	<input type="checkbox"/> SB6	\$59.95
<input type="checkbox"/> X1	\$2.95	<input type="checkbox"/> SB7	\$59.95

Name _____
Company _____
Address _____
City _____ State _____ Zip _____
 Charge my: Visa M.C. Amer. Exp.
Number _____ Exp. Date _____
Signature _____

Picking Up the Pieces

Alfred S Baker
2327 S Westminster
Wheaton IL 60187

Everything had been going so smoothly. I had just saved several important programs on a disk and had planned to spend the rest of the afternoon doing fun things with them. Now the computer was telling me that my full disk was completely empty.

I had been using my floppy disk system for over 6 months before the output error mentioned above occurred. I discovered, to my sorrow, that while input and output errors on a floppy disk are very rare, they can still happen. I survived my catastrophe. I hope that my experience can help you survive yours.

Disk Files

Generally, 2 different methods are used to place files on a floppy disk: sequential file storage, and track or sector allocation.

In the sequential file storage method, a new file is placed on the disk in the unused sectors following the last file added to the disk. This is demonstrated in figure 1. Any files that are deleted, such as file B, will generate unused space on the disk that is not used for storing new files. New files go at the end of all

previously used space. But what about all of the unused space taken up by the deleted files? Simple. These systems provide a utility program which eliminates this unused space by shifting the files on the disk. This process, which is called *compressing or packing the disk*, is shown in figure 2.

If this is the way your system works, then the data block that got wiped out on my system exists on

your system. However, as you will see, its contents and use are totally different.

The track, or sector allocation method is also known as the bit map method or chained, sequential-storage method. It is used by the more impressive, and efficient, large-system support packages. It is also used by my Peripheral Vision floppy disk operating system (FDOS).

Figure 1: In the sequential storage method, files are placed on the disk starting at the first empty sector after the last stored file.

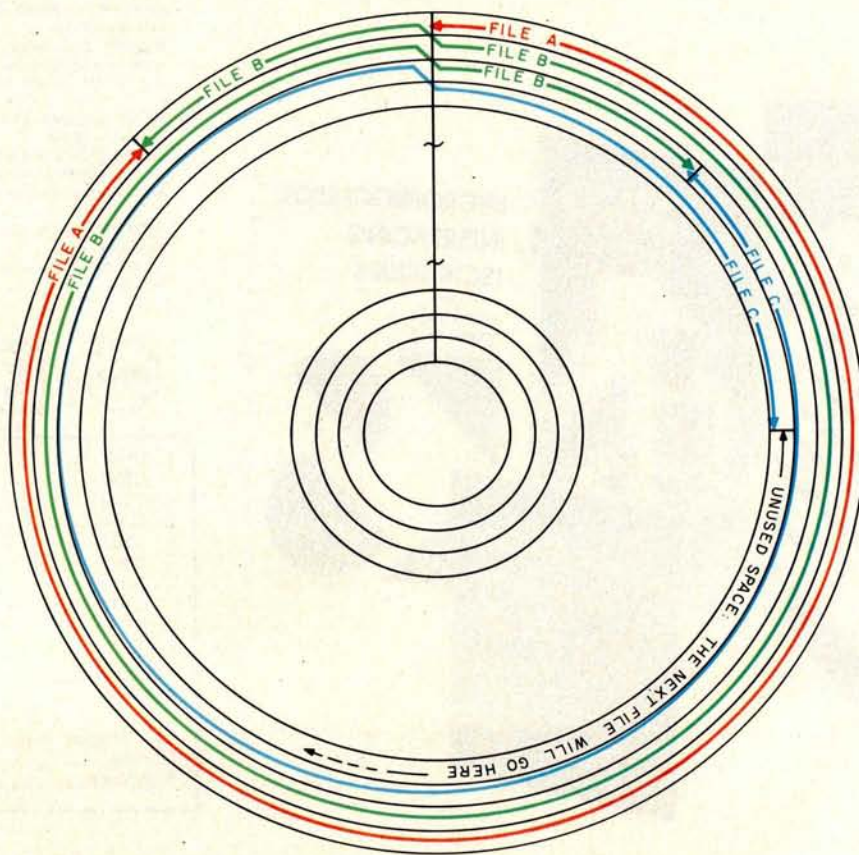

About the Author

Al Baker is 30 years old and lives with his wife, Janet, and 2 children in Wheaton IL. He is currently the programming director for The Image Producers Inc, Northbrook IL. He is a member of the American Association for the Advancement of Science, the National Space Institute, and the Chicago Area Computer Hobbyist Exchange. He says, "My favorite sports are volleyball and handball, and my hobbies are playing with computers, photography, and playing with computers."

SuperBrain™



The Honor Graduate

There's been a lot of talk lately about intelligent terminals with small systems capability. And, it's always the same. The systems which make the grade in performance usually flunk the test in price. At least that was the case until the SuperBrain graduated with the highest PPR (Price/Performance Ratio) in the history of the industry.

For less than \$3,000*, SuperBrain users get exceptional performance for just a fraction of what they'd expect to pay. Standard features include: two dual-density mini-floppies with 320K bytes of disk storage, 64K of RAM to handle even the most sophisticated programs, a CP/M Disk Operating System with a high-powered text editor, assembler and

*Quantity one. Dealer inquiries invited.

debugger. And, with SuperBrain's S-100 bus adapter, you can even add a 10 megabyte disk!

More than an intelligent terminal, the SuperBrain outperforms many other systems costing three to five times as much. Endowed with a hefty amount of available software (BASIC, FORTRAN, COBOL), the SuperBrain is ready to take on your toughest assignment. You name it! General Ledger, Accounts Receivable, Payroll, Inventory or Word Processing . . . the SuperBrain handles all of them with ease.

Your operators will praise the SuperBrain's good looks. A full ASCII keyboard with a numeric keypad and function keys. A non-glare, dynamically focused, twelve inch screen. All in an attractive desktop unit weighing less than a standard

office typewriter. Sophisticated users will acclaim SuperBrain's twin Z-80 processors which transfer data to the screen at 38 kilobaud! Interfacing a printer or modem is no problem using SuperBrain's RS-232C communications port. But best of all, you won't need a PhD in computer repair to maintain the SuperBrain. Its single board design makes servicing a snap!

So don't be fooled by all the freshman students in the small systems business. Insist on this year's honor graduate . . . the SuperBrain.

 **INTERTEC
DATA
SYSTEMS®**

2300 Broad River Road, Columbia, SC 29210
(803) 798-9100 TWX: 810-666-2115

In this method all of the space on the disk is represented by a single bit map. Each bit in the area called the bit map represents 1 physical area on the disk. In my system this area is a sector. (Refer to figure 3.) On each floppy disk there are 74 tracks represented in the bit map for that disk. (There are actually 77 tracks on the floppy disk, but the first 2 tracks contain the operating system, and the third functions as the directory, containing the bit map itself and the names and addresses of all the files on

the disk. Since each track has 16 sectors when using FDOS, the bit map contains 74 times 16, or 1184 bits. This represents 1 bit for each sector on the disk. Dividing by 8 gives a bit map size of 148 bytes. This fits easily into a single 256-byte sector on the disk.

Now we can use the bit map to determine which sectors on the disk are in use. A file program will read the bit map into memory and will find a 0 bit in the map. The sector represented by this bit is unused. If a

new file is being created and it needs another sector, FDOS turns the bit on (makes it a logic 1) and writes the bit map back onto the disk. When a file is deleted, the bits representing each sector in the file are turned off. The space is immediately available for use by another file. Now we have a way of using space on the disk which eliminates the problem of wasted space caused by the old way of doing things.

Unfortunately this method creates its own set of problems. The first problem is not very obvious. If a file is longer than 1 sector, it won't fit. The wrong solution is to try to find an area with enough empty sectors located adjacently. We might as well consider all of those areas with just a few free sectors as useless space. Also, we never know how big a file is going to be until it is too late to look for a bigger space.

The correct solution is to let each sector in the file point to the location of the next sector in the file. Look at figure 4. Here we have a 1000-byte file of data contained on four 256-byte sectors. When a program tries to read the 257th byte from the

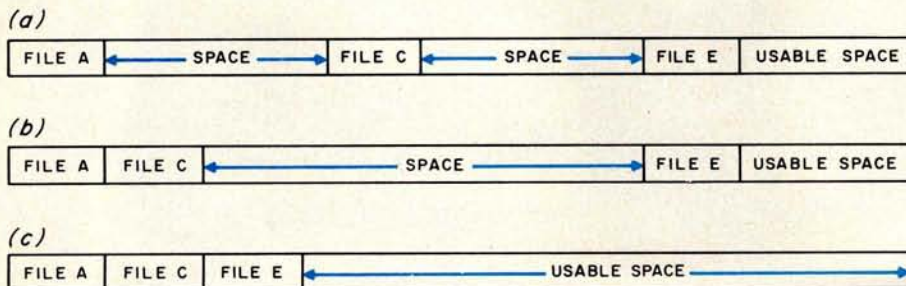

Figure 2: In a system which uses the sequential storage method, unusable space is turned into usable space by compressing the data. Starting with the data stored on the disk (2a), the usable data is shifted toward the beginning of the storage space until the files are behind each other (2b). This process is continued until all of the unusable space has been pushed to the end of the disk and is usable.

DATA TERMINAL EQUIPMENT — FROM MICROMAIL



LA34 DECwriter IV

\$1,199.00

- Upper/lower case, 9x7 dot matrix
- 10, 12, 13.2, 16.5 characters/inch
- 2, 3, 4, 6, 8 or 12 lines/inch
- 22"W x 7"H x 15 1/2"D, 25 lbs.
- 110 or 300 baud, RS 232C serial ASCII
- Friction feed, paper width to 15"

New from DIABLO

DIABLO 1640 **\$2,690.00**

Receive-only **\$2,331.00**

High-quality daisywheel printing at 45 cps.

DIABLO 1650 **\$2,779.00**

Receive-only **\$2,419.00**

Metal daisywheel printing at 40 cps.

T.I. 810 printer **\$1,695.00**

- Includes upper/lower case
- 150 characters per second
- RS 232C serial interface
- Adjustable forms tractor

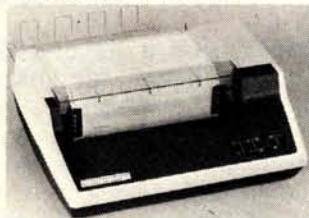

SOROC IQ 120 **\$795.00**

- RS 232C, upper/lower case, full ASCII
- Numeric keypad, protected fields
- Cursor keys plus addressable cursor
- Auxiliary extension port



SOROC IQ 140 **\$1,250.00**

- RS 232C and 20mA current loop
- Extensive editing features
- 25th line terminal status display
- 16 function keys (32 with shift)



NEC Spinwriter

Call or write for prices

To Order: Send certified check (personal or company checks require two weeks to clear) including handling* and 6% sales tax if delivered within California.

*Handling: Less than \$2,000, add 2%; over \$2,000, add 1%. Everything shipped freight collect in factory cartons with manufacturer's warranty.

MICROMAIL
 MICROMAIL • BOX 3297 • SANTA ANA, CA 92703
 (714) 731-4338

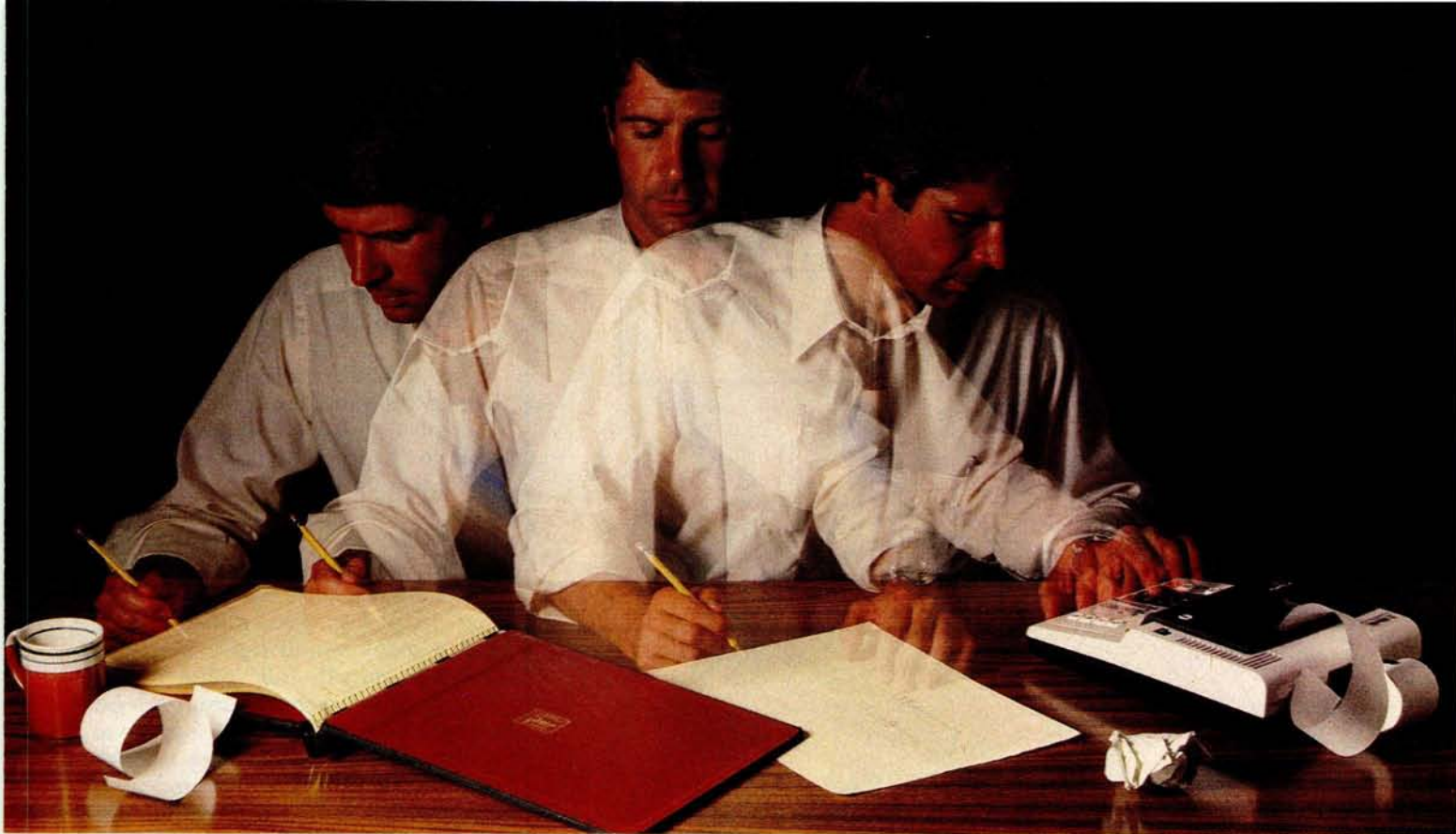

Solve your personal energy crisis. Let VisiCalc™ Power do the work.

With a calculator, pencil and paper you can spend hours planning, projecting, writing, estimating, calculating, revising, erasing and recalculating as you work toward a decision.

Or with VisiCalc and your Apple* II you can explore many more options with a fraction of the time and effort you've spent before.

VisiCalc is a new breed of problem-solving software. Unlike prepackaged software that forces you into a computerized straight jacket, VisiCalc adapts itself to any numerical problem you have. You enter numbers, alphabetic titles and formulas on your keyboard. VisiCalc organizes and displays this information on the screen. You don't have to spend your time programming.

Your energy is better spent using the results than getting them.

Say you're a business manager and want to project your annual sales. Using the calculator, pencil and paper method, you'd lay out 12 months across a sheet and fill in lines and columns of figures on products, outlets, salespeople, etc. You'd calculate by hand the subtotals and summary figures. Then you'd start revising, erasing and recalculating. With VisiCalc, you simply fill in the same figures on an electronic "sheet of paper" and let the computer do the work.

Once your first projection is complete, you're ready to use VisiCalc's unique, powerful recalculation feature. It lets you ask "What if?"; examining new options and planning for contingencies. "What if" sales drop 20 percent in March? Just type in the sales figure. VisiCalc instantly updates all other figures affected by March sales.

Or say you're an engineer working on a design problem and are wondering "What if that oscillation were damped by another 10 percent?" Or you're working on your family's expenses and wonder "What will happen to our entertainment budget if the heating bill goes up 15 percent this winter?" VisiCalc responds instantly to show you all the consequences of any change.

Once you see VisiCalc in action, you'll think of many more uses for its power. Ask your dealer for a demonstration and discover how VisiCalc can help you in your professional work and personal life.

You might find that VisiCalc alone is reason enough to own a personal computer.

VisiCalc is available now for Apple II computers with versions for other personal computers coming soon. The Apple II version costs just \$99.50 and requires a 32k disk system.

For the name and address of your nearest VisiCalc dealer, call (408) 745-7841 or write to Personal Software, Inc., Dept. B, 592 Weddell Dr., Sunnyvale, CA 94086. If your favorite dealer doesn't already carry Personal Software products, ask him to give us a call.

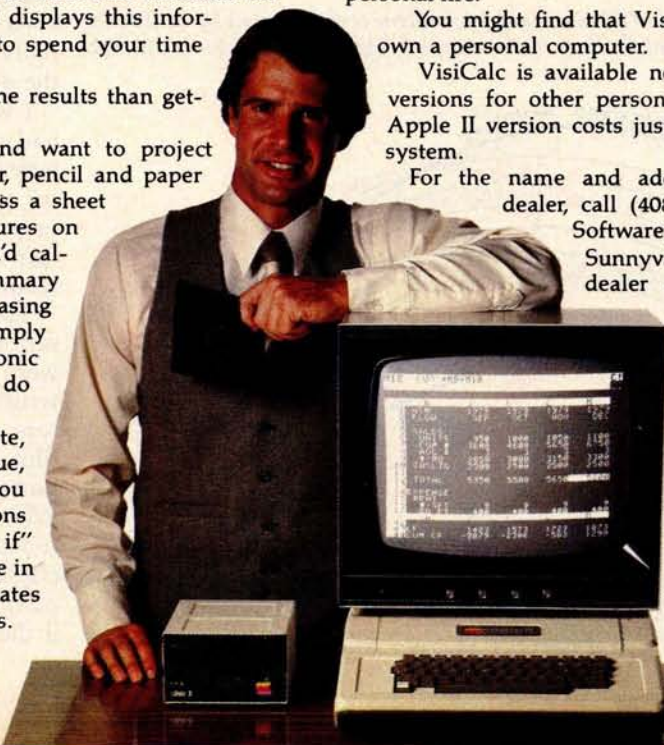

PERSONAL SOFTWARE

VisiCalc was developed exclusively for Personal Software by Software Arts, Inc., Cambridge, Mass.

TM-VisiCalc is a trademark of Personal Software, Inc.

*Apple is a registered trademark of Apple Computer, Inc.

Circle 301 on inquiry card.

A. THE BIT MAP

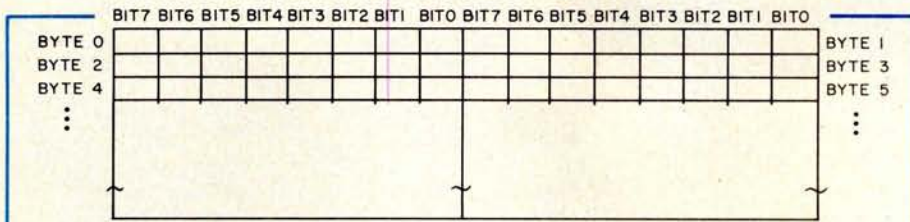

B. THE FLOPPY DISK

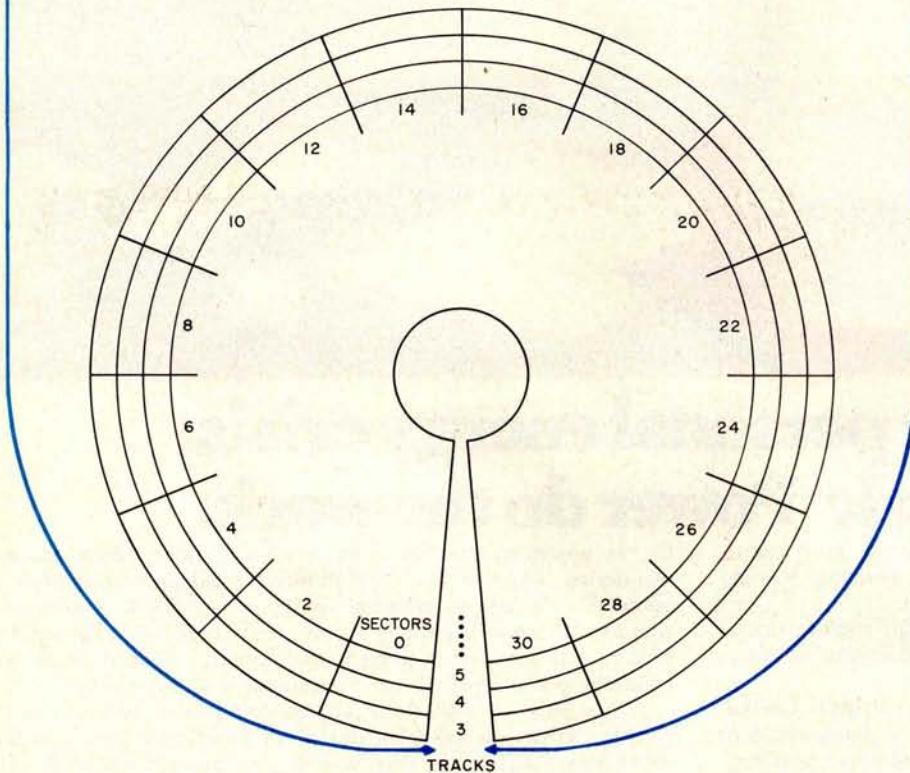

Figure 3: In the Peripheral Vision FDOS system, each sector is represented by 1 bit in the map (3a). If the bit is on (logical 1), then that sector is being used; if the bit is off, that sector is free space (3b).

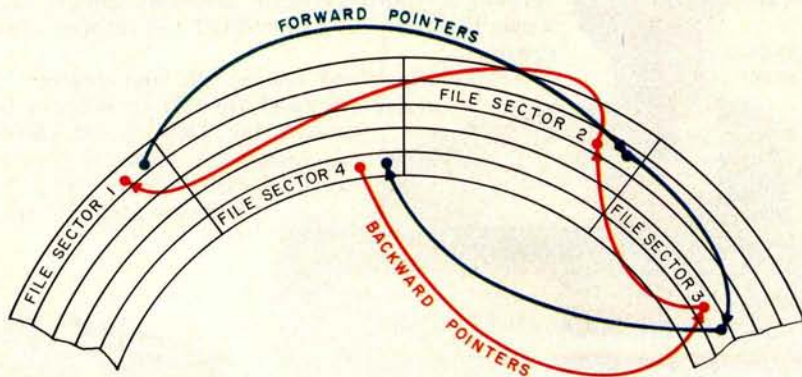

Figure 4: When a file is too long for one sector, it must be broken into several sections. Often, there are not enough contiguous sectors to contain a file. One method of solving this problem is to have bytes in the sector point to the location of the next sector. The FDOS system also has a backward pointer so 2 bytes are used.

file, FDOS automatically follows the pointer (contained in the first sector of the file) to the second sector, retrieves the first byte of that sector, and returns it to the user program. FDOS also keeps backward pointers, so you can read the file backwards, too!

The second problem is that the bit map is the most important block of data on the disk. If something happens to it, every other file space on the disk is up for grabs.

ANALIZ

One becomes accustomed to the way that machines sound in operation. I had just saved a file on disk, and it didn't sound right. Since the disk was nearly full, most of the empty sectors were far from the bit map. I had become accustomed to hearing the disk drive data transfer head make a particular sound as it moved from the bit map to the next empty sector and back to the bit map as new files were written out. The sound was missing!

I knew that something was wrong. I quickly checked the number of free sectors on the disk. The correct number should have been around 300. The answer that I got from my inquiry was 1100. Except for the file I had just written, the bit map said that I had an empty disk!

It was time for careful thought. I listed the directory: it still thought I had over 50 files on the disk. But I knew that some of those files had been destroyed, completely or partially, by the file I had just written on the disk.

I was left with 2 problems. First, I had to correct the bit map. The best way to do this was to read every sector for every file listed in the directory. As each sector was read, I could turn on its bit in the bit map. This would correct the first problem.

The second problem was more serious. I had to determine which files were destroyed. The file I had just written had almost certainly used sectors which had been part of good files. Fortunately, FDOS keeps 2-way pointers. The solution was simple. While solving the first problem, I had to read every file on the directory and check to see if each sector in a file pointed back to the previous sector. If it did not, then this sector no longer

PET / TRS-80 / APPLE: Personal Software brings you the finest!

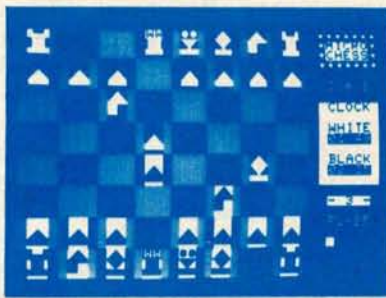

MICROCHESS
The Industry's First
Gold Cassette
Over 50,000 Sold



MICROCHESS is the industry's best selling computer game. And no wonder—because **MICROCHESS** gives you more than just a chessplaying program: A convenient, foolproof set of commands and error checks ... complete instructions in a 5½" by 8½" booklet ... a cassette that's guaranteed to load, with disk versions coming soon ... and several levels of difficulty to challenge you not just once, but time after time. It's available through well over three hundred computer stores and many mail order sources ... always

originating from Personal Software. What's more, every Personal Software product is selected to give you these same benefits of easy availability, reliable cassettes, readable documentation, a carefully thought out user interface ... and most important, continuing challenge and enjoyment, not just once but time after time. If you haven't already, order your own gold cassette: **MICROCHESS**, by **Peter Jennings**, for 8K **PETs**, 16K **APPLEs**, and 4K Level I and II **TRS-80s** **\$19.95**



TIME TREK
A Tour De Force
In Real Time Action
Strategy Games



TIME TREK by **Brad Templeton** for 8K **PETs** and **Joshua Lavinsky** for 4K Level I and II **TRS-80s** adds a dramatic new dimension to the classic Star Trek type strategy game: **REAL TIME ACTION!** You'll need fast reflexes as well as sharp wits to win in this constantly changing game. Be prepared—the Klingons will fire at you as you move, and will move themselves at the same time, even from quadrant to quadrant—but with practice you can change course and speed, aim and fire in one smooth motion, as fast as you can press the keys. Steer under power around obstacles—evade enemy

shots as they come towards you—lower your shields just long enough to fire your phasers, betting that you can get them back up in time! With nine levels of difficulty, this challenging game is easy to learn, yet takes most users months of play to master. **ADD SOUND EFFECTS** with a simple two-wire hookup to any audio amplifier; the **TRS-80** also produces sound effects directly through the keyboard case, to accompany spectacular graphics explosions! You won't want to miss this memorable version of a favorite computer game **\$14.95**

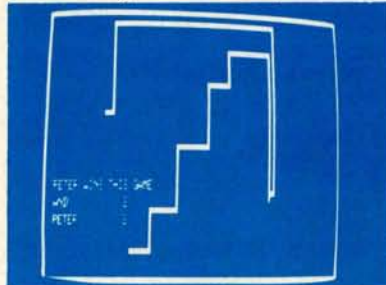

BLOCKADE by **Ken Anderson** for 4K Level I and II **TRS-80s** is a real time action game for two players, with high speed graphics in machine language. Each player uses four keys to control the direction of a moving wall. Try to force your opponent into a collision without running into a wall yourself! A strategy game at lower speeds, **BLOCKADE** turns into a tense game of reflexes and coordination at faster rates. Play on a flat or spherical course at any of ten different speeds. You can hear **SOUND EFFECTS** through a nearby AM radio—expect some razzing if you lose! **\$14.95**

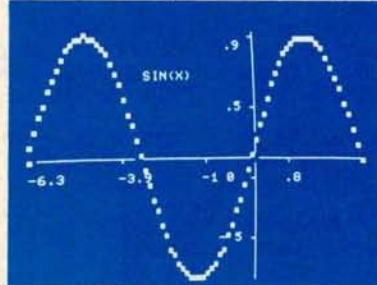

GRAPHICS PACKAGE by **Dan Fylstra** for 8K **PETs** includes programs for the most common 'practical' graphics applications: **PLOTTER** graphs both functions and data to a resolution of 80 by 50 points, with automatic scaling and labeling of the axes; **BARPLOT** produces horizontal and vertical, segmented and labeled bar graphs; **LETTER** displays messages in large block letters, using any alphanumeric or special character on the **PET** keyboard; and **DOODLER** can be used to create arbitrary screen patterns and save them on cassette or in a **BASIC** program **\$14.95**

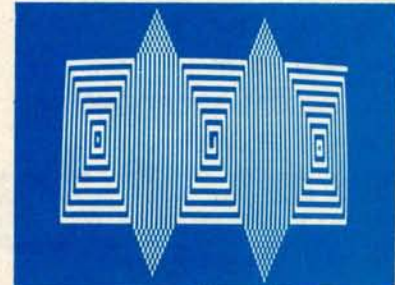

ELECTRIC PAINTBRUSH by **Ken Anderson** for 4K Level I and II **TRS-80s**: Create dazzling real time graphics displays at speeds far beyond **BASIC**, by writing 'programs' consisting of simple graphics commands for a machine language interpreter. Commands let you draw lines, turn corners, change white to black, repeat previous steps, or call other programs. The **ELECTRIC PAINTBRUSH** manual shows you how to create a variety of fascinating artistic patterns including the one pictured. Show your friends some special effects they've never seen on a TV screen! **\$14.95**

WHERE TO GET IT: Look for the **Personal Software**™ display rack at your local computer store. For the name and address of the dealer nearest you, call **Personal Software** at (408) 745-7841. If you don't have a dealer nearby, you can call or mail us your order with your check, money order or **VISA/Master Charge** card number. For a free catalog, ask your dealer or use the reader service card at the back of this magazine.

PERSONAL SOFTWARE INC.

592 WEDDELL DR. • SUNNYVALE, CA 94086

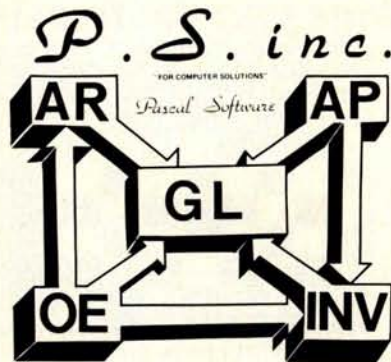

USE OUR
BUSINESS SOFTWARE
for
GREATER PROFIT
through
MORE EFFICIENT
OPERATION

INCLUDES :

- ❖ GENERAL LEDGER
- ❖ ACCOUNTS PAYABLE
- ❖ ACCOUNTS RECEIVABLE
- ❖ ORDER ENTRY
- ❖ INVENTORY CONTROL

This totally integrated, single entry system is easy to learn and easy to use because it is "Menu" oriented.

The software requires a minimum system consisting of 48K memory, CRT, Printer, dual floppy disc. It is ready to run on the following systems :

- ❖ DEC PDP - 11
- ❖ AM - 100
- ❖ PASCAL MICROENGINE
- ❖ CIT PENSEE

We are working on the following systems and feel we can install our software on them within 30 days ARO: Data General, General Automation, LSI 4/10,4/30, Some Z80 Systems

Price for the total system is \$2995.00. Order a user manual (\$25.00 plus \$2.00 shipping & handling) or the Demo Floppy & Manual (\$65.00 plus \$2.50 shipping & handling) to reserve this price for you beyond our expected price increase Nov 1, 1979.

TO ORDER USE OUR TOLL FREE NUMBER
1-800-437-4774

VISA AND MASTERCARD WELCOME
OR SEND CHECK OR MONEY ORDER TO

P. S. INC., 619 NP AVE, BOX 2017L
FARGO, ND 58107
(PH) 701/235-8145

P.S. inc.

DEALER INQUIRIES INVITED

belonged to this file. The file had been destroyed.

Now I was ready to make repairs. Very quickly, I wrote program ANALIZ (listing 1). Since I was in a hurry and wanted the program to run with no errors as soon as possible, I used structured programming techniques. Structured programming usually leads to a much shorter programming time if you include time spent debugging the code.

I'm not going to spend time telling you how the program works. Hopefully this has been accomplished with the comments in the listing. As I have said, the program is highly structured and should be easy to understand.

Conclusion

If you have Peripheral Vision FDOS, you can use the program as it is. If you have another bit-mapped disk system, then it should be a fairly straightforward matter to tailor it to your needs. If you have the sequential file storage method, then you have your own set of problems.

One final comment. Six files were destroyed on my disk. All of these files existed on the backup copy of the disk I had taken 2 weeks earlier. It is a *very good idea* to make periodic backup copies of your active disks. My only loss was a little time. I gained a better understanding of the way my disk system works, and a very interesting program.

Listing 1: Program ANALIZ is used to rebuild a bit map of the used sectors on a disk. This program is written using the TDL Z80 Relocating Assembler version 1.2. The workings of the program are explained in the comments.

```

.TITLE 'ANALYZE DISK AND FIX BITMAP'
.SBTL 'BY: A BAKER'
;
; THIS IS THE MAIN ROUTINE FOR THE DISK
; ANALYSIS PROGRAM. THIS PROGRAM TELLS
; THE USER WHICH FILES ON THE DISK HAVE
; CHAINING ERRORS. IT DOES THIS IN TWO
; WAYS. IT SIGNALS THE USER IF A CHAINED
; BLOCK DOES NOT POINT BACK TO THE BLOCK
; IT IS CHAINED TO. ALSO, IT TELLS THE
; USER IF A BLOCK DOES NOT CONTAIN A
; VALID COPY OF ITS OWN DISK ADDRESS.
; FINALLY, IF THE USER WANTS, IT WILL
; REWRITE THE DISK BITMAP. SINCE IT
; BUILDS UP THE MAP FROM VALID FILES ON
; DISK, IT CORRECTLY REFLECTS THE DISK
; CONTENTS, EVEN IF IT DID NOT BEFORE.
;
; THE ROUTINE 'INIT' SETS UP EVERYTHING,
; 'SET' DOES ALL THE WORK, AND 'END'
; CLEANS UP AND ENDS THE JOB.
0000' ANALIZ:
0000' CD 000A' CALL INIT
0003' CD 00B3' CALL SET
0006' CD 0052' CALL END
0009' C9 RET
;
; THIS ROUTINE FIRST ALLOWS THE USER
; A CHANCE TO REMOVE THE CURRENT DISK
; FROM DRIVE ZERO AND REPLACE IT WITH
; ANOTHER ONE. THIS IS DONE BY USING
; THE MESSAGE TYPING ROUTINE 'TXTYP'
; TO TYPE THE MESSAGE '..M1', AND
; RECEIVING THE REPLY VIA THE TWO
; ROUTINES 'TXTIN' AND 'TI'.
; IT LOADS THE BITMAP USING THE FDOS
; ROUTINE 'MAPIN' AND ZEROS IT.
; FINALLY, IT INITIALIZES THE NAME
; HOLDING AREA BY ENDING IT WITH A ZERO.
000A' INIT:
000A' 21 002A' LXI H, M1
000B' CD 0073 CALL TXTYP
0010' CD 0079 CALL TXTIN
0013' ..LP2:
0013' CD 0076 CALL TI
0016' 30FB JRN ..LP2
0018' CD 0686 CALL MAPIN
001B' 21 0BAC LXI H, BITMAP
001E' 0694 MVI B, 148
0020' ..LP1:
0020' 3600 MVI M, 0
0022' 23 INX H
0023' 10FB DJNZ ..LP1
0025' 97 SUB A
0026' 32 01BE STA NAMEH+9
0029' C9 RET
002A' ..M1:
002A' 4849542043 .ASCIZ 'HIT CR WHEN CO
RRECT DISK IS IN DRIVE 0:'
;
; THIS ROUTINE GETS CONTROL AFTER ALL
; THE WORK HAS BEEN DONE. IT USES THE
; 'TXTYP' ROUTINE TO ASK THE USER IF
; HE WANTS THE NEW BIT MAP PUT BACK
; ON DISK. HIS REPLY IS PICKED UP BY
; THE ROUTINES 'TXTIN' AND 'TI'. IF
; HE REPLIES YES, EITHER UPPER OR LOWER
; CASE, THE BITMAP IS WRITTEN TO DISK
; USING THE FDOS ROUTINE 'MAPOT'.
0052' END:
0052' 21 006B' LXI H, M1
0055' CD 0073 CALL TXTYP
0058' CD 0079 CALL TXTIN
005B' ..LP1:
005B' CD 0076 CALL TI
005E' F620 ORI 20H
0060' FE79 CPI 'Y'
0062' 2803 JRZ ..LP2
0064' 18F5 JMPR ..LP1
0066' C9 RET
0067' ..LP2:
0067' CD 06AA CALL MAPOT
006A' C9 RET
006B' ..M1:
006B' 444F20594F .ASCII 'DO YOU WANT TH
E BIT MAP REPLACED?'
008C' 8D BYTE 13
008D' 4245205645 .ASCIZ 'BE VEEERRY CAR
EFUL BEFORE SAYING YES:'
;
; THIS IS THE MAIN DRIVING ROUTINE FOR
; DOING ALL THE WORK. BECAUSE OF A
; DECISION TO MINIMIZE MEMORY USE, THIS
; ROUTINE IS COMPLICATED BY A DOUBLE
; USE OF THE FDOS SYSTEM INPUT BUFFER.
; THE DIRECTORY ROUTINES, 'DIROPN' AND
; 'DIRBLK' USE THIS BUFFER FOR READING
; AND MAINTAINING THE DIRECTORY AND

```

Listing 1 continued on page 84

NOW... Exclusively Yours from ACS

TRS-80[®]-DOS 3.0

Disk Operating System

by the Original Author

DOS 3.0
EFFECTIVE SEPTEMBER 1
ONLY **\$49⁹⁵**

Check these DOS 3.0 features . . .
that go far beyond 2.1

NO KEY BOUNCE • UPWARDS COMPATABLE FROM 2.1 • CHECK EOF
SEEK • RE-READ • RE-WRITE • LOC • VARIABLE LENGTH RECORDS
SKIP • DISK LOGGING OF MESSAGES • BOOT • CHAIN • WRITE EOF
PURGE • SET • RESET • ROUTE • RUN & LOAD FOR 1 DRIVE SYS.
XFER • FORMAT W/O ERASE • DIR FROM BASIC • PATCH • LINK
USER DEFINED KEYS • KEY AUTO REPEAT • UPPER AND LOWER
CASE DRIVER • SHIFT LOCK • RS-232-C DRIVERS
• PAUSE • USER DEVICE CONTROL BLOCKS
• MULTI PROTOCOL COMMUNICATIONS

HARDWARE FOR TRS-80[®]

- Pertec Disk Drives FD-200 \$375.00 ea.
These are 40-track Drives that are completely compatible with the TRS-80 and Radio Shack Drives. 3.0 DOS included. Will allow Turning Diskette over and Write on other side.
- 4-Drive Cable for Pertec Drives \$35.00
- DECwriter III, 132 Character \$2500.00
110 to 9600 band EIA tractor feed keyboard printer. This is truly the nicest printer available. (30 day delivery)
- 701 Centronics TRACTOR FEED Bidirectional Printer \$1500.00
2½ times as fast as the Radio Shack 779 Printer, has full size 132 Char. Carriage Bell tone. Complete with Cable plug in and use. Shipped Freight COD.
- 200 ns 16K Dynamic Memory Clips for Keyboard or Expansion Interface, Lifetime Guarantee, complete \$110.00
Lifetime Guarantee. Complete with Instructions and Jumper Blocks.
- 10 Key Numerical Keypad Kit \$79.95
- TRS-80[®] Level II - 16k \$750.00
 - Expansion Interface \$275.00
 - RS-232-C Interface \$ 89.00

ORDER NOW AND SAVE
Just list the items you want and mail this convenient coupon.

SOFTWARE BY ACS

- Monitor No. 3 \$29.95
Complete Machine Language Monitor for TRS-80[®] features: Find, EDIT, Relocate, Symbolic Dump to Tape, etc.
- Monitor No. 4 \$49.95
All of the commands that reside in Monitor No. 3, plus: RS-232 I/O, Disk Program I/O, Symbolic Dump to Disk for Loading into Disk Editor/ASM., Track & Sec I/O for modification.
- PCLEND \$15.95
Will Patch ASCII files of Basic Programs or text or DATA FILES so that they may be loaded into the Disk Version of the Electric Pencil for Editing purposes comes on Cassette that will automatically create a Disk file of the program.
- MAKE TAPE AND MAKE DISK for Cassette Dealers \$69.95
These are two programs that will allow you to take any type of Program from Disk and store it on tape for mailing purposes. When the user receives the program in the mail on cassette, it is loaded into the computer which will automatically make a Disk file of the program.
- CP/M & C BASIC for the TRS-80[®]
CP/M Includes: MOVCPM, STAT, PIP, Dump, DOT, ASM (8080), ED, plus 6 user manuals.
CP/M \$150.00
C Basic-2 Includes: XREF2, CBAS2, and manuals.
- C BASIC 2 \$99.95
- G2 LEVEL III BASIC for TRS-80[®] Special \$39.95
- TELCOM - Telecommunications for the TRS-80[®] \$29.95
Telecommunications for the TRS-80[®] allows one TRS-80[®] to communicate with another through the RS-232-C over the phone line.

 Orders received by 6:00 p.m. shipped next day on Master Charge, Visa, Certified Check or Money Order. Personal Checks require 14 days to clear. No C.O.D. Collect calls not accepted. All Hardware warranted for 90 days except Radio Shack equipment which is warranted through Radio Shack. Software guaranteed for replacement only. Prices subject to change without notice.

**AUTOMATED
COMPUTER
SOFTWARE SERVICE**
(615) 244-2798
Division of
Computer World INC.
625 Main Street • Nashville, TN 37206

Send Check or Money Order payable to -
SOFTWARE • P.O. Box 60097 • Nashville, TN 37206

Quan.	Description	Unit Price	Total

HANDLING CHARGE \$1.50
TENN. RES. ADD 6% SALES TAX **TOTAL**

Check
 Money Order
 MasterCard
 Visa
Card No. _____
Exp. Date _____

Name _____
Address _____
City _____ State _____ Zip _____

Listing 1 continued:

```

; I DECIDED TO USE IT TO READ THE BLOCKS
; FOR EACH FILE. FOR THIS REASON, EACH
; TIME A VALID FILE NAME IS FOUND, THE
; BUFFER (WHICH CONTAINS A DIRECTORY
; BLOCK) IS SAVED IN THE AREA 'BUFFER'.
; AFTER 'FIXIT' IS CALLED TO PROCESS
; THE CURRENT FILE, IT IS MOVED BACK
; INTO THE FDSO BUFFER 'RDFLNM' BEFORE
; GETTING THE NEXT DIRECTORY BLOCK.
;
; 'SET' IS A GRAND LOOP WHICH READS
; DIRECTORY BLOCKS. FIRST, THE DIRECTORY
; IS OPENED WITH A CALL TO FDSO AT
; 'DIROPN'. THEN EACH DIRECTORY ENTRY IS
; PROCESSED IN THE LOOP 'L1'. WHEN
; 'DIRBLK' IS CALLED TO GET THE NEXT
; DIRECTORY ENTRY, IT SETS THE
; CONDITION CODE TO ZERO IF THERE ARE
; NO MORE PRESENT. 'SET' ENDS ON THIS
; CONDITION: WE ARE THROUGH. 'DIRBLK'
; PLACES THE FIRST BYTE OF THE NAME
; OF THE FILE IN THE ACCUMULATOR. IF IT
; IS 255 DECIMAL (ALL ONES BINARY), THIS
; IS AN UNUSED ENTRY AND IS NOT TO BE
; PROCESSED. IF IT IS TO BE PROCESSED,
; 'NAMEM' IS CALLED TO SAVE THE NAME OF
; THE CURRENT FILE, 'NAME' IS CALLED TO
; PRINT OUT THIS NAME ON THE CONSOLE SO
; THE USER WILL KNOW WHICH FILE IS BEING
; PROCESSED.
; THE CURRENT DIRECTORY DISK BLOCK IS
; SAVED, 'FIXIT' IS CALLED TO PROCESS
; THE FILE, AND THE DIRECTORY BLOCK IS
; MOVED BACK.
00B3'      SET:
00B3' CD D5DF      CALL DIROPN
00B6'      L1:
00B6' CD D5EF      CALL DIRBLK
00B9' C8          RZ
00BA' FEFF        CPI 255
00BC' 28F8        JRZ L1
00BE' D5          PUSH D
00BF' CD 019E'     CALL NAMEM
00C2' CD 01AE'     CALL NAME
00C5' 21 00F3'    LXI H, R1
00C8' CD D073'    CALL TXTYP
00CB' 21 DA92'    LXI H, RDFLNM
00CE' 11 01C1'    LXI D, BUFFER
00D1' 01 0117'    LXI B, LN2SNC
00D4' ED00        LDIR
00D6' 2A D964'    LHLD TRKWNT
00D9' 22 01BF'    SHLD TRACK
00DC' D1          POP D
00DD' CD 00F4'    CALL FIXIT
00E0' 2A 01BF'    LHLD TRACK
00E3' 22 D964'    SHLD TRKWNT
00E6' 21 01C1'    LXI H, BUFFER
00E9' 11 DA92'    LXI D, RDFLNM
00EC' 01 0117'    LXI B, LN2SNC
00EF' ED00        LDIR
00F1' 18C3        JMPR L1
00F3' 8D          R1: BYTE 13+128
;
; THIS ROUTINE DOES ALL OF THE WORK FOR
; ANALYZING A SINGLE FILE ON THE DISK.
; (ACTUALLY, SINCE (I MIGHT MODESTLY
; SAY) THIS IS ONE OF THE BEST EXAMPLES
; OF A WELL STRUCTURED PROGRAM I HAVE
; EVER SEEN, 'FIXIT' JUST PROVIDES
; ANOTHER LEVEL OF CONTROL FOR THE
; 'FIXIT' FIRST CALLS 'HEAD' TO SET UP
; THE CONTROL REGISTERS TO READ THE
; FIRST BLOCK OF THE FILE. THE LOOP
; 'L1' THEN PROCESSES ALL BLOCKS IN
; THE FILE. THIS LOOP CALLS 'NEXT' TO
; GET THE NEXT DATA BLOCK IN THE FILE,
; IT THEN CALLS 'TEST' TO TEST ITS
; DISK POINTERS. IF THERE IS A PROBLEM,
; 'TEST' RETURNS A NONZERO FLAG. IN THIS
; SITUATION 'FIXIT' TERMINATES. IT DOES
; NOT CONTINUE PROCESSING A FILE WITH A
; BAD CHAIN. IF THE BLOCK IS OK IT CALLS
; 'SETMAP' TO TURN ON THE BIT IN THE
; BITMAP FOR THIS BLOCK. IT THEN CALLS

```

```

; 'LINK' TO SET UP THE CONTROL TO READ
; IN THE NEXT BLOCK OF THE FILE. IF
; THERE ARE NO MORE, 'LINK' RETURNS
; WITH A ZERO FLAG AND 'FIXIT' EXITS.
00F4'      FIXIT:
00F4' CD 0107'     CALL HEAD
00F7'      L1:
00F7' CD 0116'     CALL NEXT
00FA' CD 0121'     CALL TEST
00FD' C8          RNZ
00FE' CD 0129'     CALL SETMAP
0101' CD 0133'     CALL LINK
0104' 20F1        JRNZ L1
0106' C9          RET
;
; THIS ROUTINE SETS UP THE CONTROL
; REGISTERS, 'DE' AND 'HL' TO PROCESS
; THE FIRST BLOCK IN THE FILE. SINCE A
; BACKCHAIN TEST IS GOING TO BE MADE
; BY SOMEBODY, 'DE' WILL BE USED TO KEEP
; THE PREVIOUS BLOCKS ADDRESS WHILE 'HL'
; WILL OF COURSE BE USED TO KEEP THE
; CURRENT BLOCKS ADDRESS. FOR THE FIRST
; BLOCK IN A FILE, THE BACK POINTER IS
; DEFINED AS ZERO AND SO THIS IS THE
; VALUE PLACED IN 'DE'. THE ADDRESS OF
; THE FIRST BLOCK IN A FILE IS CONTAINED
; IN THE 10TH AND 11TH BYTES OF THE
; DIRECTORY ENTRY FOR THIS FILE. THIS
; IS A DISPLACEMENT OF +9. SINCE WE
; HAVEN'T REUSED THE FDSO BUFFER, I GET
; THIS ADDRESS FROM WHERE 'DIRBLK' TOLD
; ME THE DIRECTORY ENTRY IS. 'DIRBLK'
; HAS POINTED 'DE' TO THE CURRENT
; DIRECTORY BLOCK. THEREFORE I GET THE
; LOCATION OF THE FIRST BLOCK'S DISK
; ADDRESS BY ADDING 9 TO THIS LOCATION.
0107'      HEAD:
0107' CD 019E'     CALL NAMEM
010A' 21 0909'    LXI H, 9
010D' 19          DAD D
010E' 5E          MOV E, M
010F' 23          INX H
0110' 56          MOV D, M
0111' 21 0000'    LXI H, 0
0114' EB          XCHG
0115' C9          RET
;
; THIS ROUTINE LOADS IN THE NEXT DISK
; BLOCK FOR THIS FILE. THE FDSO ROUTINE
; 'RED256' PRESUMES THAT THE DISK
; ADDRESS OF THE BLOCK TO BE READ IN IS
; IN THE FIELD 'TRKWNT'. THEREFORE,
; THIS IS WHERE 'NEXT' PLACES IT.
0116'      NEXT:
0116' E5          PUSH H
0117' D5          PUSH D
0118' 22 D964'    SHLD TRKWNT
011B' CD D75E'    CALL RED256
011E' D1          POP D
011F' E1          POP H
0120' C9          RET
;
; THIS ROUTINE TESTS THE CHAINS FOR THE
; CURRENT FILE BLOCK. IF THERE ARE ANY
; PROBLEMS, IT RETURNS A NONZERO RETURN
; CODE. ACTUALLY, YOU WILL NOTICE THAT
; 'TEST' CALLS TWO OTHER ROUTINES WHICH
; DO ALL THE WORK. 'TESTBK' TESTS THIS
; BLOCKS BACKCHAIN AND 'TESTNM' TESTS
; THE SELF CONTAINED ADDRESS OF WHERE
; IT THINKS IT IS: ITS OWN ADDRESS.
0121'      TEST:
0121' CD 013A'     CALL TESTBK
0124' C8          RNZ
0125' CD 0168'     CALL TESTNM
0128' C9          RET
;
; THIS ROUTINE TURNS ON THE BIT IN THE
; BIT MAP CORRESPONDING TO THIS DISK
; BLOCK. THE FDSO ROUTINE 'TS2BT'
; ASSUMES THAT 'HL' CONTAINS A DISK
; BLOCK ADDRESS. IT RETURNS THE ADDRESS
; OF THE BYTE IN THE BITMAP WHICH

```

```

; CONTAINS THE BIT REPRESENTING THIS
; BLOCK. IT ZEROS REG 'A' AND THEN
; TURNS ON THE BIT IN REG 'A' WHICH
; CORRESPONDS TO THE CORRECT BIT FOR
; THIS BLOCK IN REG 'M' (THE BYTE
; POINTED AT BY 'HL'). ORING 'A' INTO
; 'M' TELLS FDSO THAT THE BLOCK IS IN
; USE. XORING 'A' INTO 'M' (TURNING OFF
; THE BIT) TELLS FDSO THAT THE BLOCK
; IS UNUSED. 'SETMAP' TURNS ON THE BIT
; TO SIGNAL THAT THE BLOCK IS IN USE.
0129'      SETMAP:
0129' E5          PUSH H
012A' D5          PUSH D
012B' CD D665'    CALL TS2BT
012E' B6          ORA M
012F' 77          MOV M, A
0130' D1          POP D
0131' E1          POP H
0132' C9          RET
;
; THIS ROUTINE SETS UP THE POINTERS FOR
; PICKING UP THE NEXT FILE BLOCK. IT
; TAKES THE CURRENT POINTER AND PUTS IT
; IN 'DE' AND PLACES THE ADDRESS OF THE
; NEXT BLOCK IN 'HL'. IT RETURNS A ZERO
; FLAG IF THERE ARE NO MORE BLOCKS IN
; THIS FILE.
0133'      LINK:
0133' EB          XCHG
0134' 2A DA00'    LHLD RFLNKL
0137' 7D          MOV A, L
0138' B4          ORA H
0139' C9          RET
;
; THIS ROUTINE TESTS THE BACK CHAIN
; POINTER. IT TAKES THE BACK CHAIN
; POINTER FROM THE REVERSE LINK 'RRVLNK'
; AND COMPARES IT TO 'DE' USING THE
; 'DSBC' INSTRUCTION. IF EVERYTHING IS
; OK, IT RETURNS A ZERO FLAG. OTHERWISE,
; IT CALLS NAME TO PRINT THE NAME OF
; THIS FILE AND THEN PRINTS AN ERROR
; MESSAGE.
013A'      TESTBK:
013A' E5          PUSH H
013B' D5          PUSH D
013C' 2A DA9E'    LHLD RRVLNK
013F' 97          SUB A
0140' ED52        DSBC D
0142' D1          POP D
0143' E1          POP H
0144' C8          RZ
0145' F5          PUSH PSW
0146' CD 01AE'     CALL NAME
0149' 21 0151'    LXI H, M1
014C' CD D073'    CALL TXTYP
014F' F1          POP PSW
0150' C9          RET
0151'      M1:
0151' 2040415320' ASCII 'HAS A BAD BAC
K CHAIN.'
0167' 8D          BYTE 13+128
;
; THIS ROUTINE TESTS THE ADDRESS THAT
; THIS FILE BLOCK THINKS THAT IT IS
; LOCATED AT. THIS VALUE, AT 'TRKRED',
; SHOULD MATCH THE CONTENTS OF 'HL'.
; THIS IS TESTED USING THE 'DSBC'
; INSTRUCTION. IF EQUAL, A ZERO FLAG IS
; RETURNED. OTHERWISE, THE NAME OF THE
; CURRENT FILE IS PRINTED OUT USING THE
; ROUTINE 'NAME' AND AN ERROR MESSAGE
; IS TYPED OUT.
0168'      TESTNM:
0168' E5          PUSH H
0169' D5          PUSH D
016A' ED5B DA9C'  LDED TRKRED
016E' 97          SUB A,
016F' ED52        DSBC D
0171' D1          POP D
0172' E1          POP H
0173' C8          RZ
0174' F5          PUSH PSW

```

Listing 1 continued on page 86

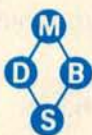

the Ultimate Software Tool:

AVAILABLE FROM

Micro Data Base Systems, inc.

MDBS IS A VERSATILE DATA BASE MANAGEMENT SYSTEM

- PROVIDES FLEXIBILITY OF A FULL NETWORK DATA BASE SYSTEM
- EFFECTIVE REPRESENTATION OF COMPLEX DATA STRUCTURES
- RECORDS CAN BE ORDERED ON VARIOUS SORT KEYS
- COMMANDS TO ADD, DELETE, UPDATE, SEARCH AND TRAVERSE THE DATA BASE
- SORTED, FIFO, LIFO, NEXT AND PRIOR SET ORDERING PROVIDED
- PROVIDES DATA PROTECTION
- STRAIGHTFORWARD USE OF ISAM-LIKE STRUCTURES
- COMPARABLE TO DATA BASE SYSTEMS PREVIOUSLY AVAILABLE ONLY ON LARGER COMPUTERS

MDBS IS CODASYL ORIENTED WITH EXTENSIONS

- EXPLICIT REPRESENTATION OF MANY-TO-MANY SETS
- RECORD TYPES MAY OWN OTHER OCCURRENCES OF THE SAME RECORD TYPE
- DIFFERENT RECORD TYPES CAN PARTICIPATE IN A SINGLE SET
- MULTIPLE LEVELS OF READ/WRITE PROTECTION
- NAMES OF DATA ITEMS, RECORDS, SETS AND FILES ARE WHOLLY USER DEFINABLE

MDBS IS FOR THE SERIOUS APPLICATIONS PROGRAMMER

- POWERFUL COMPONENT IN INFORMATION PROCESSING
- RELIEVES TEDIUM OF FILE HANDLING DETAILS
- OEMS CAN RAPIDLY AND INEXPENSIVELY DEVELOP APPLICATION SOFTWARE
- USEFUL IN DISTRIBUTED PROCESSING ENDEAVORS

SOFTWARE DELIVERED ON MINI-OR FULL-SIZED FLOPPY DISKS
USING CP/M[®], NORTH STAR, OR TRS-80[®] COMPATIBLE FORMATS

- **MDBS INTRODUCTORY OFFER \$750.00**
- **USERS MANUAL (alone) \$35.00**
- **Distributors and OEMS Contact MDBS for Special Rates**
- **Application Programming Contracts will be Considered.**

Indiana Residents Include 4% Sales Tax.

CP/M is a registered trademark of Digital Research Corp.
TRS-80 is a registered trademark of Radio Shack/Tandy Corp.

FEATURES

- WRITTEN IN Z-80 CODE FOR MAXIMAL EXECUTION EFFICIENCY AND MINIMAL MEMORY USAGE. (8080 VERSION EXTRA).
- ROUTINES ARE CALLABLE FROM BASIC (OR OTHER HOST LANGUAGES) TO FACILITATE FAST AND EASY APPLICATION PROGRAMMING.
- ROUTINES CAN BE ORGED TO SATISFY USER REQUIREMENTS.
- SUPPORTS DATA BASES SPREAD OVER SEVERAL DISK DRIVES (MAXIMUM OF 8). DISKS MAY BE MINI-OR FULL-SIZED FLOPPIES OR HARD DISKS.
- I/O AND HOST LANGUAGE INTERFACE ROUTINES ARE ISOLATED FOR EASY ADAPTATION. PATCHES FOR MANY COMMON OPERATING SYSTEMS/BASIC LANGUAGE COMBINATIONS AVAILABLE.

REQUIREMENTS

- Z-80 Based System (8080 Systems Extra, 6502 Version Forthcoming)
- 8 to 16K Bytes (Depending on Options) in Addition to the Operating System, Host Language and Users Program.

PACKAGE INCLUDES

MDBS-DDL DATA DEFINITION LANGUAGE ANALYZER/EDITOR. The user specifies data structures to be used in a concise Data Definition Language (DDL). The MDBS Data Definition Language Analyzer/Editor allows the user to interactively create and edit DDL specifications and to initialize the data base for use based on these specifications.

200 PAGE USERS MANUAL with extensive documentation of the MDBS System.

MDBS-DMS DATA MANAGEMENT ROUTINES. These are the routines callable from the host language (BASIC, PASCAL, etc.) which perform the data base operations of finding, adding, and deleting records; fetching and storing data items; and traversing the (possibly complex) data structure.

SAMPLE APPLICATION PROGRAMS written in North Star BASIC which illustrate various features of MDBS.

MICRO DATA BASE SYSTEMS, INC

P.O. BOX 248 LAFAYETTE, IN 47902

(317) 742-7388

Listing 1 continued:

```

0175' CD 01AE'    CALL NAME
0178' Z1 0180'    LXI H, .M1
017B' CD 0073    CALL TXTYP
017E' F1         POP PSW
017F' C9         RET
0180'           .M1:
0180' 2048415320 .ASCII ' HAS AN INVALID
D DISK ADDRESS.'
0190' 80         .BYTE 13+128
;
; THIS ROUTINE COPIES THE CURRENT FILE
; NAME OUT OF THE DIRECTORY ENTRY WHICH
; IS POINTED TO BY 'DE' INTO THE HOLDING
; AREA 'NAMEH'.
019E'           NAMEM:
019E' E5         PUSH H
019F' D5         PUSH D
01A0' C5         PUSH B
01A1' EB         XCHG
01A2' 11 01B5'   LXI D, NAMEH
01A5' 01 0009    LXI B, 9
01A8' EDB0      LDIR
01AA' C1         POP B
01AB' D1         POP D
01AC' E1         POP H
01AD' C9         RET
;
; THIS ROUTINE PRINTS THE NAME OF THE
; CURRENT FILE, WHICH IS IN 'NAMEH',
; USING THE FDOS MESSAGE PRINT ROUTINE
; 'TXTYP'.
01AE'           NAME:
01AE' Z1 01B5'   LXI H, NAMEH
01B1' CD 0073    CALL TXTYP
01B4' C9         RET
01B5'           NAMEH: .BLKB 10
01BF'           TRACK: .BLKW 1
01C1'           BUFFER: .BLKB 300H
;
; THESE ARE THE GENERAL ROUTINES DEFINED
; FOR THE USER TO USE WITHIN FDOS.
%FDGSSMCKX
D055           BYTIN = 0D055H
; C INPUT A CHARACTER FROM THE DISK
; I HL->DISK BUFFER
; O CY=EOF, A=BYTE
; K INPUT DISK BYTE IO
;
D058           BYTOT = 0D058H
; C OUTPUT A CHARACTER TO THE DISK
; I HL->DISK BUFFER, C=BYTE
; O
; M FLAGS
; K OUTPUT DISK BYTE IO
;
D05B           BLKIN = 0D05BH
; C READ A BLOCK FROM DISK
; I HL->DISK BUFFER, BUFFER+14 CONTAINS
; I TRACK AND SECTOR TO BE READ IN.
; O CY=FAIL, BUFFER+14=NEXT BLOCK IN
; O CHAIN
; K INPUT DISK BLOCK IO
;
D05E           BLKOT = 0D05EH
; C WRITE A BLOCK TO DISK
; I HL->BLOCK IN BUFFER, BUFFER+10
; I CONTAINS ITS DESTINATION DISK ADDR.
; O CY=FAIL, BUFFER+10 IS DESTINATION OF
; O NEXT BLOCK
; K OUTPUT DISK BLOCK IO
;
D064           OPNIN = 0D064H
; C OPEN INPUT DISK FILE
; I HL-> BUFFER CONTAINING NAME
; O CY=FAIL
; K INPUT OPEN DISK
;
D067           OPNOT = 0D067H
; C OPEN OUTPUT DISK FILE
; I HL-> BUFFER CONTAINING NAME
; O CY=FAIL
; K OUTPUT OPEN DISK
;
D06A           CLSOT = 0D06AH
; C CLOSE AN OUTPUT DISK FILE
; I HL-> BUFFER
; O
; K CLOSE OUTPUT DISK
;
; THESE ARE THE IMPORTANT FIELDS WITHIN
; THE TWO FDOS SYSTEM BUFFERS.
%FDBSYSMCKX
DBAC           BITMAP = 0DBACH
; C ADDRESS OF BITMAP WHEN IN MEMORY
; I
; O
; K DISK DATA BLOCK CONTROL LOOKUP MEMORY
; BITMAP
;
D073           TXTYP = 0D073H
; C OUTPUT A MESSAGE TO THE CONSOLE
; I HL-> MESSAGE ENDING IN '00' BIT ON
; OR '00' BYTE
; O HL-> STOP CHAR
; C
; K OUTPUT CONSOLE ASCII BLOCK
;
D076           TI = 0D076H
; C INPUT FROM CONSOLE AND SET FLAGS
; I
; O A=BYTE CY=X'13' Z=' '
; K INPUT CONSOLE BYTE
;
D079           TXTIN = 0D079H
; C NO-OP
; I
; O
; K
;
; THESE ARE IMPORTANT ROUTINES DEFINED
; WITHIN FDOS. THEY ARE NOT DEFINED FOR
; THE USER TO USE. HOWEVER, I AM USING
; THEM ANYWAY.
%FDSSYSMCKX
D686           MAPIN = 0D686H
; C READ IN ALLOCATION BITMAP OFF DISK
; I
; O
; K INPUT DISK LOOKUP BITMAP
;
D6AA           MAPOT = 0D6AAH
; C PUT BITMAP BACK ON DISK
; I
; O
; K OUTPUT DISK LOOKUP BITMAP
;
D75E           RED256 = 0D75EH
; C READ IN RECORD TO SYTEM INPUT BUFFER
; I
; O
; C EVERYTHING
; K INPUT DISK
;
D665           TS2BT = 0D665H
; C CONVERTS A DISK ADDRESS TO A BITMAP
; ADDRESS AND BIT
; I HL=TRACK AND SECTOR
; O HL->BYTE IN BIT MAP, A=BIT IN BIT MAP
; K CONVERSION DISK LOOKUP BITMAP
;
; THESE ROUTINES CONTROL I/O TO THE
; DISK DIRECTORY.
%FDRSYSMCKX
D5EF           DIRBLK = 0D5EFH
; C GET THE NEXT DIRECTORY ENTRY
; I
; O DE-> BLOCK
; A=FIRST CHAR IN NAME
; CY=END OF DIR, Z=FIRST NEVER USED
; M=DELETED AND AVAILABLE
; K INPUT DISK DIRECTORY
;
D5DF           DIROPN = 0D5DFH
; C OPEN DISK DIRECTORY FILE
; I
; O
; K INPUT OPEN DIRECTORY DISK

```



HOW BOB SCHMIDT AND HIS MICROSOFT BASIC COMPILER TURNED AN ORDINARY COMPUTER INTO A GENIUS.

Bob admits he thought his computer had reached the limit of its capabilities. Then he discovered the BASIC Compiler from Microsoft.

"It's incredibly fast," he boasts. "Nothing was as fast as my Microsoft BASIC interpreter—yet this new compiler is actually 3-10 times faster.

"And that's not all," he beamed. "My compiler has the same language features as Microsoft 5.0 BASIC and runs in my 32K CP/M system."

Bob says, "When Microsoft comes out with a new product, I know it's got to be good. And this BASIC Compiler is the wizard I've been waiting for.

"At last, I can generate relocatable machine language modules from my Microsoft BASIC programs—machine code that's highly optimized. And because the Microsoft macro assembler and loader come with the BASIC Compiler, BASIC programs are easily linked to assembly language subroutines or Microsoft

FORTRAN and COBOL programs. Just like the pros," smiled Bob.

"What's more, the compiler generates a fully symbolic listing of the machine language that's generated—a great way for me to learn assembly code on my own."

Bob believes in giving credit where credit is due. "Microsoft turned my BASIC computer into a genius for \$395, but I was smart enough to recognize a good thing immediately."

If you want to get the most out of your computer and your BASIC programs, ask for more information on the Microsoft BASIC Compiler. We know you'll compliment yourself on a very smart move.

MICROSOFT



10800 N.E. Eighth Suite 819
Bellevue, Washington 98004
206/455-8080 Telex 328945

We set the standard.

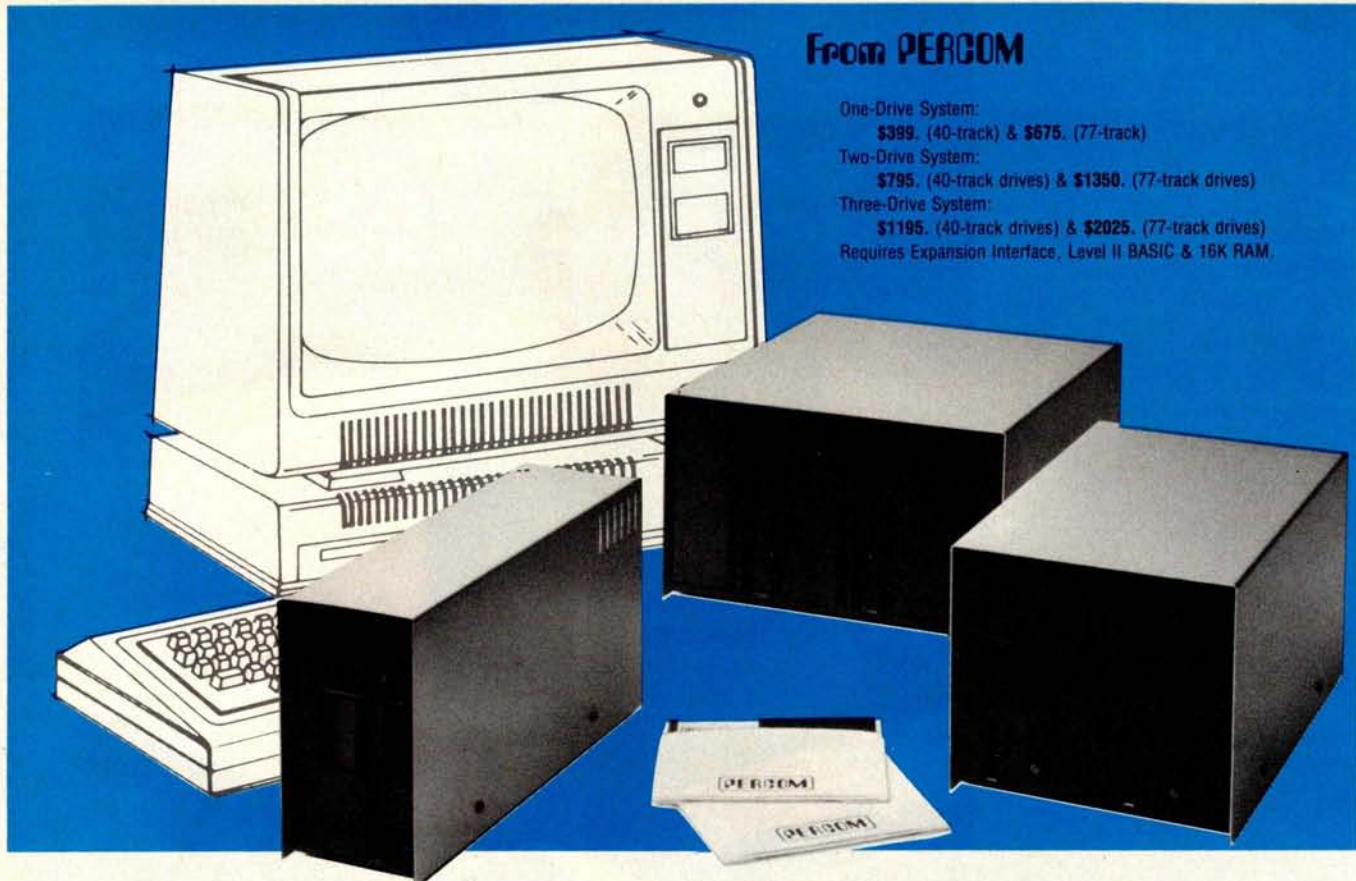

From PERCOM

One-Drive System:
\$399. (40-track) & **\$675.** (77-track)
 Two-Drive System:
\$795. (40-track drives) & **\$1350.** (77-track drives)
 Three-Drive System:
\$1195. (40-track drives) & **\$2025.** (77-track drives)
 Requires Expansion Interface, Level II BASIC & 16K RAM

Low Cost Add-On Storage for Your TRS-80* . In the Size You Want.

When you're ready for add-on disk storage, we're ready for you.
 Ready with six mini-disk storage systems — 102K bytes to 591K bytes of
 additional *on-line* storage for your TRS-80* .

- Choose either 40-track TFD-100™ drives or 77-track TFD-200™ drives.
- One-, two- and three-drive systems immediately available.
- Systems include Percom PATCH PAK #1™, on disk, at no extra charge. PATCH PAK #1™ de-glitches and upgrades TRSDOS* for 40- and 77-track operation.
- TFD-100™ drives accommodate "flippy disks." Store 205K bytes per mini-disk.
- Low prices. A single-drive TFD-100™ costs just \$399. Price includes PATCH PAK #1™ disk.
- Enclosures are finished in system-compatible "Tandy-silver" enamel.

Whether you need a single, 40-track TFD-100™ add-on or a three-drive add-on with 77-track TFD-200™s, you get more data storage for less money from Percom.

Our TFD-100™ drive, for example, lets you store 102.4K bytes of data on one side of a disk — compared to 80K bytes on a TRS-80* mini-disk drive — and 102.4K bytes on the other side, too. Something you can't do with a TRS-80* drive. That's almost 205K bytes per mini-disk.

And the TFD-200™ drives provide 197K bytes of on-line storage per drive

— 197K, 394K and 591K bytes for one-, two and three-drive systems.

PATCH PAK #1™, our upgrade program for your TRSDOS*, not only extends TRSDOS* to accommodate 40- and 77-track drives, it enhances TRSDOS* in other ways as well. PATCH PAK #1™ is supplied with each drive system at no additional charge.

The reason you get more for less from Percom is simple. Peripherals are not a sideline at Percom. Selling disk systems and other peripherals is our main business — the reason you get more engineering, more reliability and more back up support for less money.

In the Product Development Queue . . . a *printer interface* for using your TRS-80* with any serial printer, and . . . the *Electric Crayon™* to map your computer memory onto your color TV screen — for games, animated shows, business displays, graphs, etc. Coming PDQ!

™ TFD-100, TFD-200, PATCH PAK and Electric Crayon are trademarks of PERCOM DATA COMPANY.

*TRS-80 and TRSDOS are trademarks of Tandy Corporation and Radio Shack which have no relationship to PERCOM DATA COMPANY.

PERCOM

PERCOM DATA COMPANY, INC.
 DEPT. B • 211 N. KIRBY • GARLAND, TX. 75042

To order add-on mini-disk storage for your TRS-80* , or request additional literature, call Percom's toll-free number: 1-800-527-1592. For detailed Technical information call (214) 272-3421.

Orders may be paid by check or money order, or charged to Visa or Master Charge credit accounts. Texas residents must add 5% sales tax.

Percom 'peripherals for personal computing'

For your SWTP 6800 Computer . . .

PERCOM's™ FLOPPY DISK SYSTEM

the LFD-400

Ready to plug in and run the moment you receive it. Nothing else to buy, no extra memory. No "booting" with PerCom MINIDOS-PLUSX™, the remarkable disk operating system on EPROM. Expandable to either two or three drives. Outstanding operating, utility and application programs.

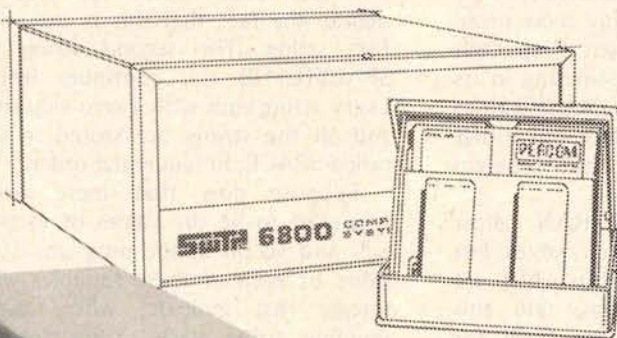

To order
or request
literature
call PerCom
toll-free
1-800-527-1592.

only
\$599⁹⁵

fully assembled and tested
shipping paid

PERCOM™

PERCOM DATA COMPANY, INC.

211 N. Kirby Garland, TX 75042
(214) 272-3421

For the low \$599.95 price, you not only get the disk drive, drive power supply, SS-50 bus controller/interface card, and MINIDOS-PLUSX™, you also receive:

- an attractive metal enclosure
- a fully assembled and tested interconnecting cable
- a 70-page instruction manual that includes operating instructions, schematics, service procedures and a complete listing of MINIDOS™
- technical memo updates — helpful hints which supplement the manual instructions
- a 90-day limited warranty.

SOFTWARE FOR THE LFD-400 SYSTEM

Disk operating and file management systems

INDEX™ The most advanced disk operating and file management system available for the 6800. Interrupt Driven EXecutive operating system features file-and-device-independent, queue-buffered character stream I/O. Linked-file disk architecture, with automatic file creation and allocation for ASCII and binary files, supports sequential and semi-random access disk files. Multi-level file name directory includes name, extension, version, protection and date. Requires 8K RAM at \$A000. Diskette includes numerous utilities \$99.95

BASIC Interpreters and Compilers

SUPER BASIC A 10K extended disk BASIC interpreter for the 6800. Faster than SWTP BASIC. Handles data files. Programs may be prepared using a text editor described below \$49.95

BASIC BAND-AID™ Turn SWTP 8K BASIC into a random access data file disk BASIC. Includes many speed improvements, and program disk CHAINing \$17.95

STRUBAL+™ A STRUctured BASIC Language compiler for the professional programmer. 14-digit floating point, strings, scientific functions, 2-dimensional arrays. Requires 20K RAM and Linkage Editor (see below). Use of the following text editors to prepare programs. Complete with RUN-TIME and FLOATING POINT packages \$249.95

Text Editors and Processors

EDIT68 Hemenway Associates' powerful disk-based text editor. May be used to create programs and data files. Supports MACROS which perform complex, repetitive editing functions. Permits text files larger than available RAM to be created and edited \$39.95

TOUCHUP™ Modifies TSC's Text Editor and Text Processor for PerCom disk operation. ROLL function permits text files larger than available RAM to be created and edited. Supplied on diskette complete with source listing \$17.95

Assemblers

PerCom 6800 SYMBOLIC ASSEMBLER Specify assembly options at time of assembly with this symbolic assembler. Source listing on diskette \$29.95

MACRO-RELOCATING ASSEMBLER Hemenway Associates' assembler for the programming professional. Generates relocatable linking object code. Supports MACROS. Permits conditional assembly \$79.95

LINKAGE EDITOR — for STRUBAL+™ and the MACRO-Relocating assembler \$49.95

CROSS REFERENCE Utility program that produces a cross-reference listing of an input source listing file \$29.95

Business Applications

GENERAL LEDGER SYSTEM Accommodates up to 250 accounts. Financial information immediately available — no sorting required. Audit trail information permits tracking from GL record data back to source document. User defines account numbers \$199.95

FULL FUNCTION MAILING LIST 700 addresses per diskette. Powerful search, sort, create and update capability \$99.95

PERCOM FINDER™ General purpose information retrieval system and data base manager \$99.95

™ trademark of PERCOM Data Company, Inc.

™ trademark of Hemenway Associates Company.

Now! The LFD-800 and LFD-1000. Add one, two or three LFD-800 drives and store 200K bytes per drive on-line. Add one or two (dual-drive) LFD-1000 units and store 800K bytes per unit on-line. Complete with interface/controller, DOS, cable & manuals. **Two-drive** systems: LFD-800 — \$1549; LFD-1000 — \$2495.

PERCOM 'peripherals for personal computing'

Variables Whose Values Are Strings

W D Maurer
University Library Building
George Washington University
Washington DC 20052

Almost every programmer has wanted to write a program in which there were one or more variables with strings as their values. Many programmers, however, are discouraged by the programming difficulties that arise in this connection, in all but the simplest cases. This is particularly true when space is at a premium and assembly language is used as it is in many microcomputer applications. We would like to describe here two alternative ways of solving these problems. These are quite different from each other stylistically; each is fascinating in its own way, and each has certain difficulties which have to be surmounted, but either one of them will solve the basic problem with which we are concerned.

Many versions of FORTRAN allow variables to have strings as their values, but these strings cannot have lengths which are greater than some maximum, and this maximum is usually much too small for practical purposes. The maximum is, in fact, the number of characters in a word, which is usually two, four or six; sometimes it is five (as on the PDP-10) and sometimes eight (as on the IBM 370, using double words), but in practice the strings we are concerned with are often 20, 40 or even 60 characters long. In many COBOL programs, this problem is taken care of by assigning some large number of characters to every such variable. This is particularly common when the value of the variable is somebody's name and address, to be printed on an envelope by the computer. Often 25 characters are reserved for the name, 25 for the address, and 25 for the city, state and zip code. This gives rise to two kinds of problems. In the first place, 25 characters is not enough for an address like 1527 San Jose-Los Gatos Rd., even if we leave the period off the end. More important, however, is the fact that, if we reserve that many characters for every name and every address, there are going to be quite a lot of wasted characters. That doesn't matter too much in a COBOL program, where space, particularly on a disk, is usually quite abundant; but on a microcomputer we would like to make optimum use of all the space we have.

The first solution to this problem that we will consider involves the use of a large array, called SPACE, for the storage of strings. Let us consider each element of this array to be one character long. Then the first string (whose length is L1, say) is stored in the characters SPACE(1), SPACE(2) and so on up through SPACE(L1). The next character, SPACE(L1+1), contains an illegal character code (zero, for example) to denote the fact that this is the end of the first string. The second string starts at SPACE(L1+2) and continues from there. Every string ends with a zero character code, and all the strings are stored in the array called SPACE, in sequential order.

Suppose now that these strings are supposed to be the values of variables K1, K2 and so on in the program. The actual value of each of these variables will be an integer that indicates where the corresponding string starts. Thus, for example, if 17 is the value of K2, then SPACE(17) is the first character of the given string; SPACE(18) is the next character, and so on. This is the basic concept of a *pointer*: a quantity which indicates where another quantity is in memory. The pointers we have set up have been *index pointers*, but it would have been just as easy to set up *address pointers*. That is, instead of the integer 17, we could have used the address, in memory, of the character SPACE(17).

The basic problem that arises when this method is used can be seen if we consider the process of setting a variable to a new value. Suppose that the value of K1 is 'SMITH' and we want to change it to 'JOHNSON'. Unfortunately, 'JOHNSON' has more letters in it than 'SMITH', so we cannot simply store the new characters in the same places as we stored the old ones. We can, however, take advantage of the fact that not all of our array SPACE has been used. Suppose that we have used the characters from SPACE(1) up through SPACE(LSPACE); then 'JOHNSON' can start at SPACE(LSPACE+1), and we can set the pointer in K1 to be LSPACE+1. Of course, we also have to update LSPACE at this point, by adding to it the length

of JOHNSON, or 7 (plus 1, for the zero character).

The trouble with this method is that now SMITH is still in memory, together with its zero character. We are not really using *all* the space from SPACE(1) up through SPACE(LSPACE); there are five characters, plus a zero character, that we are not using. By itself this causes no problems; but now consider what happens as our program continues to run. Every time we have a variable with a string as its value, and this variable gets a new string as its value, we are going to "abandon" some of our string storage area, just as we did with SMITH in this case. Eventually, we are going to run out of space; the whole SPACE array will be used up, except for "abandoned" areas as above. What do we do next?

Let us agree that, whenever we abandon a string, we write a zero character over the first character of that string. This character will immediately follow the zero character at the end of the preceding string, so that two zero characters in a row will denote the start of an abandoned area. We can now consider the possibility of moving all the strings backwards by just enough so that the abandoned areas disappear, as shown in figure 1. This is known as *collapsing* (or sometimes *compactifying*). If we think of the left side of figure 1 as a row of bricks, with spaces between them to represent the abandoned areas, then putting our hands on the two ends of the row and collapsing it would produce the situation shown in the right side of the figure.

An algorithm to do this involves two pointers, I and J. As we move each character in SPACE, we set $SPACE(J) = SPACE(I)$, and then add 1 to both I and J. When we have to skip over an abandoned area, we increase I, but not J. Thus I always indicates the current character we are moving, and J always indicates the place we are moving it. At the start of the algorithm, both I and J are initialized to 1.

There is still one difficulty. All our variables with string values involve pointers, and after the collapsing process has taken place, the pointers will be wrong. We have to have some way of adjusting these pointer values. There are at least two reasonable ways of doing this. One of these involves what may be called *back pointers*. The first character (or possibly the first two characters) of each string, as given in the array SPACE, is now some indication of which variable has this particular string as its value (such as, for example, the address of that variable). Whenever a back pointer is moved, by the operation $SPACE(J) = SPACE(I)$, we

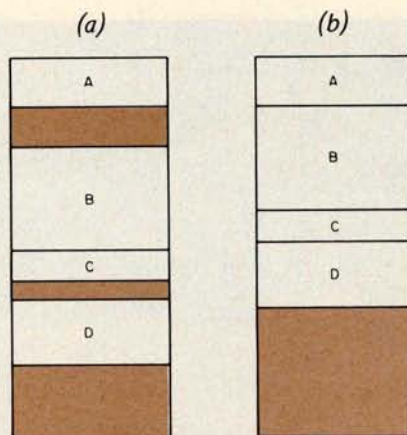

Figure 1: Collapsing or "compactifying" an array. In figure 1a A, B, C and D are separated by empty space (shaded area). In figure 1b this empty, available space is consolidated by moving B, C and D up so that they are contiguous with A.

look in that position (which should contain I) and change it to J.

The other method involves a sorting operation. All the pointers that are contained in all the variables with string values are placed in an array and sorted in ascending order, together with back pointers to the given variables. As we are going through the SPACE array and setting $SPACE(J) = SPACE(I)$, we are also going through this new array, from the beginning to the end. At each stage, the pointer in this array that we are currently considering points to the place in the SPACE array that we will have to treat next, as the start of a string to be moved. When we get to this point in SPACE, we reference the associated back pointer and proceed as before; then we continue through the SPACE array, but also move forward by one position in the new array, so that we will be ready to treat that pointer when we come to it.

Let us now pass to the second method of handling string values of variables. Again we use a large array, which we will call FREE this time, rather than SPACE. FREE is organized into groups of characters; to make our example concrete, we will assume that each group is eight characters long. The first six of these characters are actually characters of the given string; the remaining two character positions, taken together, contain a pointer to another group of eight characters.

Any string which is less than six characters long is stored in a single group. If a string is four characters long, for example, the last two characters are zero characters; this tells us that these are not actually to be counted as part of the string. A string which is more than six characters long is stored as a chain. Thus, for example, if a string is 15 characters long, the first six of these characters appear in one group, which contains a pointer to another group. The next six characters appear in this second group,

Whenever we abandon a string, we write a zero character over the first character of that string so we can go back later and identify the string as abandoned.

UP TO 2400 MEGABYTES OF HARD DISK CONTROL FOR THE S-100 BUS

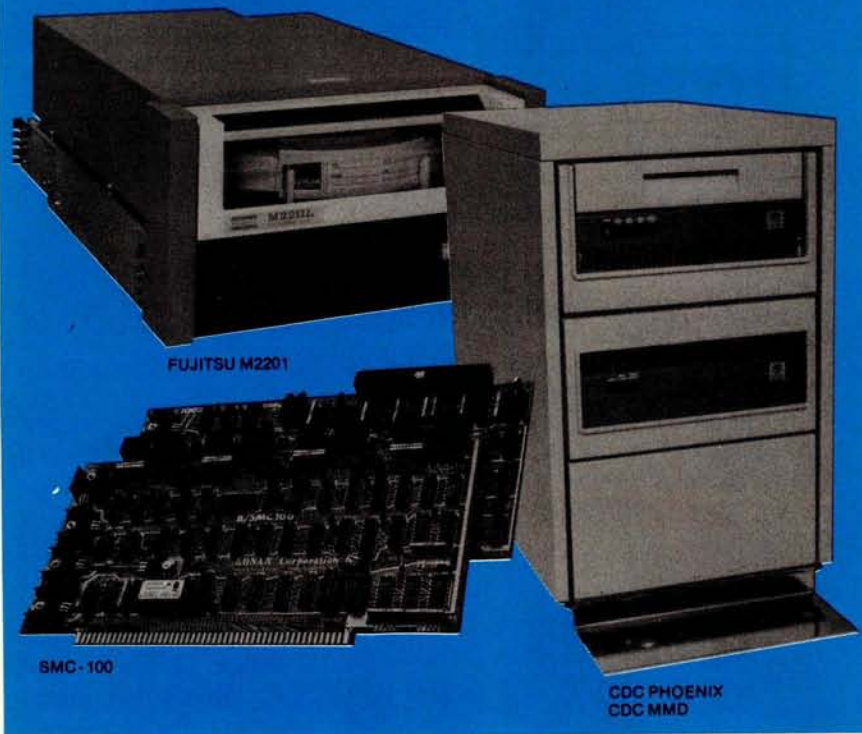

Konan's SMC-100 is versatile, fast, cost efficient. It's the disk controller that brings S-100 bus micro computers together with large capacity hard disk drives.

Versatile

Interfaces S-100 bus micro computers with all fixed or removable media disk drives with storage module (SMD) interfaces. Each Konan SMC-100 will control up to 4 drives ranging from 8 to 600 megabytes per drive, including most "Winchester" type drives. Up to 2400 megabytes of hard disk per controller! And you can take your pick of hard disk drives: Kennedy, Control Data, Fujitsu, Calcomp, Microdata, Memorex, and Ampex, for example.

Fast

SMC-100 transfers data at fast, 6 to 10 megahertz rates, with full onboard sector buffering and sector interleaving, and a DMA that's faster than other popular S-100 DMA controllers.

Cost efficient

SMC-100 is priced right to keep your micro computer system micro-priced. It takes advantage of low-cost-per-megabyte disk drive technology to make the typical cost less than \$80 per megabyte. The OEM/Dealer single quantity price is only \$1650, with driver ROM option. Excellent quantity discounts are available.

SMC-100 availability:

Off the shelf to 30 days in small quantities. (Complete subsystems are on hand for immediated delivery.)

Konan has the answers. Talk to them today. Call direct on Konan's order number: 602-269-2649. Or write to Konan Corporation, 1448 N. 27th Avenue, Phoenix, Arizona 85009.

KONAN™

1448 N. 27th Avenue • Phoenix, Arizona 85009 • 602-269-2649

which contains a pointer to a third group. The last three characters appear in the third group, followed by three zero characters.

If a string is exactly six characters long, it appears in a single group, but the pointer itself contains zero. If a string is 12, 18, 24, etc, characters long, it appears in more than one group, but the pointer in the last group will contain zero. In general, the pointer in the last group always contains zero, and it is this, rather than the presence of zero characters, that determines the fact that it is the last group.

We thus have one or more *chains* (sometimes called *simple lists*) which involve various 8 character groups in FREE. We are now in a position to make use of a basic idea in advanced programming techniques: the *list of available space*. In this case, the list of available space is a chain which contains all those 8 character groups, and only those groups, which are *not* on any other chain. That is, we think of all these groups as being in some order (it does not matter what the order is). Then the first group, in this order, contains a pointer to the second group; the second group contains a pointer to the third, and so on, up to the last group, which contains a zero pointer.

The point of using a list of available space is that it is now no longer necessary to use a collapsing process, as described in connection with the previous string storage method. In particular, we are no longer "abandoning" anything, as we were before. All we have to do is to make sure that, at all times, *every* group into which FREE is divided is on some chain, either the list of available space, or a chain which represents the string value of some variable. (There are also programs which use a list of available space, but in which some groups are abandoned, and a process somewhat like collapsing, known as *garbage collection*, is used to collect all these abandoned groups into a new list of available space. This, however, is necessary only when the various chains contain pointers to each other, which is not the case in the present application.)

By a pointer to a group, we mean a pointer to the first character in the group. Thus if K is such a pointer, then the group consists of FREE(K), FREE(K+1) and so on up through FREE(K+7). We will assume that FREE(K) through FREE(K+5) are the six characters in the group, and that FREE(K+6) and FREE(K+7), taken together, are the pointer to the next group. A variable called LAVS (for "list of available space") contains, at all times, a pointer to the *first group* in the list of available space. The basic operations on the list of available space are taking one group off

DELTA

IS READY . . .

WITH WITH WITH

32K or 16K RAM



- 16K or 32K Static Memory. ● S-100 Bus Connector. ● 9 Regulators provide excellent heat distribution. ● Extended addressing (bank switching).
- Low power requirement. ● Phantom line.
- 20-Page operating manual. ● Full 1-year warranty. ● 32K version assembled and tested \$485.00. ● 16K version available assembled and tested, \$290.00.

Double Density Disk Controller 8" or 5"

This
One



Works!!

- Designed for CPM®. ● On Board Boot.
- 2MHz-4MHz Operation. ● Switch Selectable Write Precomp. ● "Personality Board" to modify drive configurations (no jumper wires). ● 2 Data separators; one digital, one analog. ● Drive Diagnostic Software included. ● Complete documentation. ● Runs without occupying any system RAM. ● Transparent Density Select. ● \$385.00.

SOLUTIONS SOLUTIONS SOLUTIONS

DP Z-80 CPU



- 2MHz or 4MHz operation (jumper selectable).
- Power on jump to On Board Eprom (2708 or 2716).
- M1 Wait State for 160% thrupt enhancement with 450ns memory. ● 3 Parallel I/O ports.
- Two Serial RS-232 I/O ports. ● Baud rates: 50 to 19.2K. ● \$260.00.

(Cable and Eprom extra)

ALL YOU EVER NEED!!

DP S-100 Mainframe



- 12 slot S-100 Motherboard with power supply +8@20a, ±16@6a (nylon card guides).
- Mates with disk systems shown in center column.
- Neat, compact, extremely reliable mainframe.
- Also available with S-44 2 user, 3 CPU system with features similar to Multi-user TRS-80 Expansion Package. ● Kit \$295.00

Disk Drive Storage



- Cabinet comes with multiple power.
- Supply to suit all popular disk drives ±5@5a, +24@6a.
- DP-1000K Twin double density Shugart SA-800B or Siemens FDD-100-8. (2 megabytes). ● \$1350.00
- DP-2000K Double sided, double density Shugart SA-850-R or Siemens FDD-200-8 (2 megabytes). ● \$1850.00
- Drive box less drives with ample power supply. ● Kit \$295.00

Ultimate TRS-80 Expansion Package - 340K of Double Density



- Cost effective Z-80 15 slot dual drive S-44 5" computer. Mates with TRS-80 or with terminal.
- Excellent expandable starter system for small business.
- Also an unbeatable choice for dedicated word processor applications or industrial scientific use (80 x 24 video).
- The S-44 card set ensemble is specifically designed for business engineering and technical applications.
- 50-60 Hz (110/220VAC).
- Provides expansion to 64K CPM operating system, modems, multiuser, etc. ● \$1775.00 (32K)

West:

DELTA PRODUCTS

1653 E. 28th Street
Long Beach, Calif. 90806
Tel: (213) 595-7505



East:

DELTA PRODUCTS

1254 South Cedar Road
New Lenox, Illinois 60451
Tel: (815) 485-9072

Start Computing For Just \$129.95 With An 8085-Based Professional Computer Kit—

Explorer/85

100% compatible with all 8080A and 8085 software & development tools!

No matter what your future computing plans may be, Level "A"—at \$129.95—is your starting point.

Starting at just \$129.95 for a Level "A" operating system, you can now build the exact computer you want. Explorer/85 can be your beginner's system, OEM controller, or IBM-formatted 8" disk small business system... yet you're never forced to spend a penny for a component or feature you don't want and you can expand in small, affordable steps!

Now, for just \$129.95, you can own the first level of a fully expandable computer with professional capabilities—a computer which features the advanced Intel 8085 cpu, thereby giving you immediate access to all software and development tools that exist for both the 8085 and its 8080A predecessor (they are 100% software compatible)—a computer which features onboard S-100 bus expansion—plus instant conversion to mass storage disk memory with either 5-1/4" diskettes or standard IBM-formatted 8" disks.

For just \$129.95 (plus the cost of a power supply, keyboard/terminal and RF modulator, if you don't have them already), Explorer/85 lets you begin computing on a significant level... applying the principles discussed in leading computer magazines... developing "state of the art" computer solutions for both the industrial and leisure environment.

Level "A" Specifications

Explorer/85's Level "A" system features the advanced Intel 8085 cpu, an 8355 ROM with 2k deluxe monitor/operating system, and an 8155 ROM-I/O—all on a single motherboard with room for RAM/ROM/PROM/EPROM and S-100 expansion, plus generous prototyping space.

(Level "A" makes a perfect OEM controller for industrial applications and is available in a special Hex Version which can be programmed using the Netronics Hex Keypad/Display.)

PC Board: glass epoxy, plated through holes with solder mask

I/O: provisions for 25-pin (DB25) connector for terminal serial I/O, which can also support a paper tape reader... provision for 24-pin DIP socket for hex keyboard/display... cassette tape recorder input... cassette tape recorder output... LED output indicator on SOD (serial output) line... printer interface (less drivers)... total of four 8-bit plus one 6-bit I/O ports • Crystal Frequency: 6.144 MHz • Control Switches: reset and user (RST 7.5) interrupt... additional provisions for RST 5.5, 6.5 and TRAP interrupts onboard • Counter/Timer: programmable, 14-bit binary • System RAM: 256 bytes located at F800, ideal for smaller systems and for use as an isolated stack area in expanded systems... RAM expandable to 64k via S-100 bus or 4K on motherboard.

System Monitor (Terminal Version): 2k bytes of deluxe system monitor ROM located at F800 leaving 0000 free for user RAM/ROM. Features include tape load with labeling... tape dump with labeling... examine/change contents of memory... insert data... warm start... examine and change all registers... single step with register display at each break point, a debugging/training feature... go to execution address... move blocks of memory from one location to another... fill blocks of memory with a constant... display blocks of memory... automatic baud rate selection... variable display line length control (1-255 characters/line)... channelized I/O monitor routine with 8-bit parallel output for high speed printer... serial console in and console out channel so that monitor can communicate with I/O ports.

System Monitor (Hex Version): Tape load with labeling... tape dump with labeling... examine/change contents of memory... insert data... warm start... examine and change all registers... single step with register display at each break point, a debugging/training feature... go to execution address... move blocks of memory from one location to another... fill blocks of memory with a constant... display blocks of memory... automatic baud rate selection... variable display line length control (1-255 characters/line)... channelized I/O monitor routine with 8-bit parallel output for high speed printer... serial console in and console out channel so that monitor can communicate with I/O ports.

System Monitor (Hex Version): Tape load with labeling... tape dump with labeling... examine/change contents of memory... insert data... warm start... examine and change all registers... single step with register display at each break point, a debugging/training feature... go to execution address... move blocks of memory from one location to another... fill blocks of memory with a constant... display blocks of memory... automatic baud rate selection... variable display line length control (1-255 characters/line)... channelized I/O monitor routine with 8-bit parallel output for high speed printer... serial console in and console out channel so that monitor can communicate with I/O ports.



By Netronics
registers... single step with register display at each break point... go to execution address. Level "A" in the Hex Version makes a perfect controller for industrial applications and can be programmed using the Netronics Hex Keypad/Display.



Hex Keypad/Display.

Hex Keypad/Display Specifications

Calculator type keypad with 24 system defined and 16 user defined keys. 6 digit calculator type display which displays full address plus data as well as register and status information.

Level "B" Specifications

Level "B" provides the S-100 signals plus buffers/drivers to support up to six S-100 bus boards and includes: address decoding for onboard 4k RAM expansion select-able in 4k blocks... address decoding for onboard 8k EPROM expansion select-able in 8k blocks... address and data bus drivers for onboard expansion... wait state generator (jumper select-able), to allow the use of slower memories... two separate 5 volt regulators.



Explorer/85 with Level C card cage.

Level "C" Specifications

Level "C" expands Explorer's motherboard with a card cage, allowing you to plug up to six S-100 cards directly into the motherboard. Both cage and cards are neatly contained inside Explorer's deluxe steel cabinet. Level "C" includes a sheet metal superstructure, a 5-card gold plated S-100 extension PC board which plugs into the motherboard. Just add required number of S-100 connectors

Level "D" Specifications

Level "D" provides 4k or RAM, power supply regulation, filtering decoupling components and sockets to expand your Explorer/85 memory to 4k (plus the original 256 bytes located in the 8155A). The static RAM can be located anywhere from 0000 to EFFF in 4k blocks.

Level "E" Specifications

Level "E" adds sockets for 8k of EPROM to use the popular Intel 2716 or the TI 2516. It includes all sockets, power supply regulator, heat sink, filtering and decoupling components. Sockets may also be used for soon to be available RAM IC's (allowing for up to 12k of onboard RAM).

Order A Coordinated Explorer/85 Applications Pak!

Experimenter's Pak (SAVE \$12.50)—Buy Level "A" and Hex Keypad/Display for \$199.90 and get FREE Intel 8085 user's manual plus FREE postage & handling!

Student Pak (SAVE \$24.45)—Buy Level "A," ASCII Keyboard/Computer Terminal, and Power Supply for \$319.85 and get FREE RF Modulator plus FREE Intel 8085 user's manual plus FREE postage & handling!

Engineering Pak (SAVE \$41.00)—Buy Levels "A," "B," "C," "D," and "E" with Power Supply, ASCII Keyboard/Computer Terminal, and six S-100 Bus Connectors for \$514.75 and get 10 FREE computer grade cassette tapes plus FREE 8085 user's manual plus FREE postage & handling!

Business Pak (SAVE \$89.95)—Buy Explorer/85 Levels "A," "B," and "C" (with cabinet), Power Supply, ASCII Keyboard/Computer Terminal (with cabinet), 16k RAM, 12" Video Monitor, North Star 5-1/4" Disk Drive (includes North Star BASIC) with power supply and cabinet, all for just \$1599.40 and get 10 FREE 5-1/4" minidisettes (\$49.95 value) plus FREE 8085 user's manual plus FREE postage & handling!

Continental U.S.A. Credit Card Buyers Outside Connecticut

CALL TOLL FREE 800-243-7428

To Order From Connecticut Or For Technical Assistance, Etc. Call (203) 354-9375

Netronics R&D Ltd., Dept. RE 10
333 Litchfield Road, New Milford, CT 06676

Please send the items checked below—

- Explorer/85 Level "A" Kit (ASCII Version), \$129.95 plus \$3 p&h.
- Explorer/85 Level "A" Kit (Hex Version), \$129.95 plus \$3 p&h.
- 8k Microsoft BASIC on cassette tape, \$64.95 postpaid.
- 8k Microsoft BASIC in ROM Kit (requires Levels "B," "D," and "E"), \$99.95 plus \$2 p&h.
- Level "B" (S-100) Kit, \$49.95 plus \$2 p&h.
- Level "C" (S-100 6-card expander) Kit, \$39.95 plus \$2 p&h.
- Level "D" (4k RAM) Kit, \$69.95 plus \$2 p&h.
- Level "E" (EPROM/ROM) Kit, \$5.95 plus 50¢ p&h.
- Deluxe Steel Cabinet for Explorer/85, \$49.95 plus \$3 p&h.
- ASCII Keyboard/Computer Terminal Kit (features a full 128 character set, upper & lower case, full cursor control, 75 ohm video output convertible to baudot output, selectable baud rate, RS232-C or 20 ma. I/O, 32 or 64 character by 16 line formats, and can be used with either a CRT monitor or a TV set (if you have an RF modulator), \$149.95 plus \$2.50 p&h.
- Hex Keypad/Display Kit, \$69.95

plus \$2 p&h.

- Deluxe Steel Cabinet for ASCII Keyboard/Terminal, \$19.95 plus \$2.50 p&h.
- Power Supply Kit (± 8V @ 5 amps) in deluxe steel cabinet, \$39.95 plus \$2 p&h.
- Gold Plated S-100 Bus Connectors, \$4.85 each, postpaid.
- RF Modulator Kit (allows you to use your TV set as a monitor), \$8.95 postpaid.
- 16k RAM Kit (S-100 Board expands to 64k), \$199.95 plus \$2 p&h.
- 32k RAM Kit, \$329.95 plus \$2 p&h.
- 48k RAM Kit, \$459.95 plus \$2 p&h.
- 64k RAM Kit, \$589.95 plus \$2 p&h.
- 16k RAM Expansion Kit (to expand any of the above up to 64k), \$139.95 plus \$2 p&h each.
- Intel 8085 cpu User's Manual, \$7.50 postpaid.
- Special Computer Grade Cassette Tapes, \$1.90 each or 3 for \$5, postpaid.
- 12" Video Monitor (10 MHz bandwidth), \$139.95 plus \$5 p&h.
- North Star Double Density Floppy Disk Kit (One Drive) for Explorer/85 (includes 3 drive S-100 controller, DOS, and extended BASIC with per-

sonalized disk operating system—just plug it in and you're up and running!), \$699.95 plus \$5 p&h.

- Power Supply Kit for North Star Disk Drive, \$39.95 plus \$2 p&h.
- Deluxe Case for North Star Disk Drive, \$39.95 plus \$2 p&h.
- Experimenter's Pak (see above), \$199.90 postpaid.
- Student Pak (see above), \$319.85 postpaid.
- Engineering Pak (see above), \$514.75 postpaid.
- Business Pak (see above), \$1599.40 postpaid.

Total Enclosed \$

(Conn. res. add sales tax) By—
 Personal Check M.O./Cashier's Check Visa Master Charge

(Bank # _____)

Acct. # _____ Exp. Date _____

Signature _____ Print _____

Name _____ Address _____

City _____ State _____ Zip _____

Send Me Information

the front of it and adding a new group to it. The first of these operations, removing a group from the list of available space, is performed as follows:

1. Set K = LAVS; the new group will consist of FREE(K) through FREE (K+7).
2. Since this group is no longer to be on the list of available space, the first group in this list is now what used to be the second group. But a pointer to this second group is currently in FREE(K+6) and FREE(K+7). This pointer now has to be taken and put into LAVS, because LAVS must contain, at all times, a pointer to the first group in the list of available space.

The second of our two operations, adding a group to the list of available space, is performed as follows:

1. Suppose that FREE(K) through FREE (K+7) is the new group. This will become the first group in the list of available space, and it must contain a pointer to the second group. But the second group is the old first group, and a pointer to that group was contained in LAVS. This means that LAVS must be moved into the pointer position FREE(K+6) and FREE(K+7).
2. Since LAVS must contain, at all times, a pointer to the first group in the list of available space, we must now set LAVS equal to K.

The first operation above can be modified to check for overflow. If it is performed when the list of available space contains exactly one group, it is not hard to see that LAVS will be set equal to zero. This is not in itself an error; it merely means that all available space is being used. The next time we do this, though, there will be an error unless we check for it. Therefore, when we set K = LAVS, we should check to see if K is now zero; if so, there is an overflow condition. (We are, of course, using the word "overflow" in a generalized sense, to denote the fact that there is too much space being used for the available memory in the FREE array.)

Using these two basic operations, we can now make sure that our available space list is always kept up to date. Suppose that we have a variable J with a string value, and suppose that this string value is kept in m 8 bit groups. A pointer to the first of these groups will be kept in J itself. Suppose that we are now going to set J to a new string

Text continued on page 97



HOW STANLEY BEEMER AND MICROSOFT'S COBOL-80 TURNED THE OFFICE ON ITS EAR.

Stanley's office staff says Stanley always stays one step ahead. So no one was surprised when he showed up with Microsoft's COBOL-80 for the office computer. That's when things started happening.

As Stanley explains, "Suddenly, the whole business operation is more efficient. I use it for everything: inventory, payroll, record keeping, customer and employee files. Since COBOL is the standard language for business and commercial applications, more programs are written in COBOL than any other language. Believe me, nothing beats it in terms of powerful use of disk files, data manipulation facilities and interactive terminal communications."

Stanley added loudly, "And that's versatility and efficiency I'd like to see more of around here."

"My COBOL-80 package from Microsoft includes the MACRO-80 assembler, LINK-80 linking loader and LIB-80 relocatable library manager. I can even call FORTRAN, BASIC, assembler and COBOL modules from a COBOL-80 program. It's perfect—a total software development package," exclaimed Stanley.

Microsoft's COBOL-80 is an ANSI-74 standard COBOL that supports such advanced data manipulation verbs as COMPUTE, INSPECT, STRING, UNSTRING AND SEARCH: three-dimensional arrays; full COPY facility; and com-

plete screen handling capability. The optional packed decimal format saves on mass storage by as much as 40%. And as Stanley puts it, "With my floppy disk system, that's a big plus."

Stanley can't say enough about his new addition to the office. "COBOL-80 supports indexed and relative files, including DYNAMIC access, FILE STATUS, START, READ NEXT, DELETE and REWRITE. Best of all, interactive ACCEPT/DISPLAY gives the most powerful screen handling capability possible.

"Frankly," says Stanley, "Microsoft COBOL-80's performance is so superior it's set a whole new standard of efficiency for my staff. My new motto? 'Shape up or ship out.' Thanks Microsoft, my office will never be the same."

The COBOL-80 package for the CP/M or ISIS-II operating system with documentation is \$750. Documentation may be purchased separately for \$20. Dealer purchases and OEM license agreements available on request.

MICROSOFT



10800 N.E. Eighth Suite 819
Bellevue, Washington 98004
206/455-8080 Telex 328945

Circle 233 on inquiry card.

We set the standard.

free freight

No handling charges or credit card fees.

We'll pay the surface freight on all pre-paid products featured in this ad to any of 18,000 U.S. tariffed locations. Before you buy mail-order, check the source. Find out the TOTAL cost, including handling charges! Then compare with our one, low price!

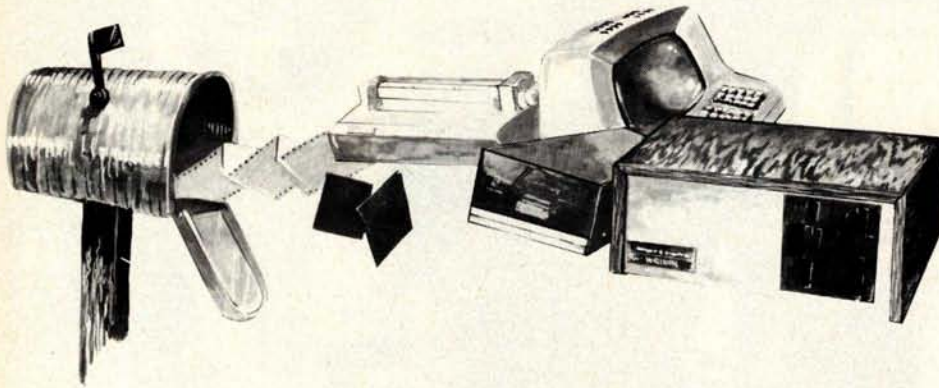

Bringing information technology to your doorstep...with no add-on costs.

Sample the experience and integrity of over 100 industry-trained employees who stand behind every order.

	Comprint Serial \$535 Parallel \$499	Centronics Model 730 New! Save \$100 Parallel \$895	
	Televideo Model 912 full-feature CRT. \$790	TI 810 Basic 150 cps serial New low price! \$1589	
	Centronics Model 704, 180 cps Loaded! Super price! \$1695	Integral Data IP-125 Printer \$699	
	Heath WH-89 16K computer w/disk! Assembled, plus factory warranty! \$CALL	Hazeltine Model 1420, full-feature CRT! 2-yr. factory warranty! \$895	

PLUS: TI calculators, Speak N Spells, Craig Translators, BSR X-10 remote control consoles, Hazeltines, Sorocs, Perkin-Elmer Bantams, Heath WH14 printers, Diablos, Cromemcos, ADDS 25 and much much more!

F.O.B. Tempe, AZ (5% sales tax in Arizona). Prices subject to change without notice...so CALL NOW WHILE IN STOCK!

TOLL-FREE
1-800-528-1418

1425 W. 12th Pl. • Tempe, AZ 85281 • 602-894-1193
 96 BYTE October 1979



Circle 234 on inquiry card.

Text continued from page 94:

value, which is kept in n 8 bit groups. First we apply the second algorithm above to the first group in the chain that represents the old value of J . This process puts this group on the list of available space. If $m \neq 1$, that is, if the pointer in this first group was not originally zero, we apply the same process to the second group in the chain representing the old value of J , and so on through the rest of these groups. (It is not necessary to know m , of course; we merely test for the pointer being zero, which indicates the last group.) Now we take n groups, or, in general, as many groups as we need, off the front of the list of available space by using the first algorithm above, and use these groups to store the new string value of J .

This system is quite workable as it stands; the only real problems with it come when we try to extend it. Suppose, for example, that we want to set the string value of J equal to the current string value of I . In that case we might want to save quite a bit of time by setting the pointer in J to be the same as the pointer in I . Thus we would have two pointers to the same group, or to the first group of the same chain, in the FREE area. This scheme, however, will not work unless we change our setup a bit. The problem comes when the value of I is later changed to something else. In this case the old value of I is put back on the list of available space, and this is improper because it is still the current value of J .

Let us look at this case in more detail. Suppose that the value of I is 'SMITH', and we set J equal to 'SMITH' by setting J to point to the same place that I does. Now suppose that we later set I equal to 'JOHNSON'. In this case, according to the algorithms we have discussed, the group [there is only one in this case; let us call it FREE(K) through FREE(K+7)] which contains 'SMITH' is put back on the list of available space, even though K is still the integer value of J . Now we need two groups to represent 'JOHNSON'. One of these will be this same group, that is, FREE(K) through FREE(K+7), because it was just put back on the beginning of the list of available space. This group will therefore contain JOHNSO (with the final N in the next group). This means that if at some still later time we want to print out the value of J , we will print out JOHNSON rather than SMITH.

One solution to this problem which is sometimes adopted is to reserve the first character of any string for a special integer telling us how many variables have this particular string as their value. This integer is known as a *reference count*. It is usually 1, but in the case above (where J and I point

to the same string) it would be 2. Every time a variable is set to a new value, the reference count in the *old* value is decreased by 1. Only if its value is then zero do we return the space it uses back to the list of available space, because otherwise there are still variables which have that string as their value. The trouble with this scheme is that it may very easily not be worth the effort. Do we really want to add an extra character to every string, not to mention the extra testing that goes on whenever we set a string to a new value, just to be able to save a little time and space in an operation (setting one string to be the same as another) that might not be that commonly used in our program? It is certainly a debatable point.

It should also be clear that there is nothing special about the number of characters in a group (eight, in this case). The fewer characters we have in a group, the more pointers we will have, and the more space these will take up. The more characters we have in a group, the more wasted or zero characters we will have in strings, because the length of a string is not always evenly divisible by the number of characters in a group. This is a space trade-off which should be tuned by the user to fit the requirements of a particular program. ■

	List	Our Price
CROMEMCO 20% DISCOUNT		
System III	5990	4792
System II	3990	3192
System II with 10 Meg Disk	9995	7996
NORTH STAR 16% DISCOUNT (or more)		
Horizon I - 32K Ram asm	2099	1763
Horizon I - 16K Ram asm	1899	1595
Horizon I - 32K Ram kit	1849	1553
Horizon I to Horizon 2	450	378
32K Ram asm	659	525
VECTOR GRAPHICS 20% DISCOUNT		
Vector MZ-2 (630K disk) 48K Ram	3750	3000
Soroc IQ120	995	790
Perkin Elmer Bantam CRT	996	750
Intertube II	995	750
Integral Data IP125	799	699
Escon Selectric Interface	496	422
NEC 5510 RO Word Processor Printer	2900	2450

Professional A/r, A/p, Ledger, Payroll, Medical Billing software with customization available. Send for our catalog - Some prices are too low to quote.

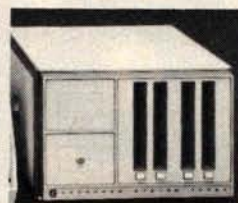

**SARA TECH
COMPUTERS**
P.O. Box 692
400 Base
Venice, FL
33595
(813)485-3559



Software with Manual / Manual Alone

DIGITAL RESEARCH

- CP/M* Floppy Diskette Operating System** — Packages supplied on diskette complete with 8080 assembler, text editor, 8080 debugger and various utilities plus full documentation. CP/M available configured for most popular computer/disk systems including: North Star Single, Double or Quad density, Altair 8" disks, Helios II, Exidy Sorcerer, Vector MZ, PolyMorphic 8813†, Heath H17† or H89†, TRS-80†, iCOM 3712 and iCOM Micro Disk plus many other configurations available off the shelf **\$145/\$25**
- MAC** — 8080 Macro Assembler. Full Intel macro definitions. Pseudo Ops include RPC, IRP, REPT, TITLE, PAGE, and MACLIB. Z-80 library included. Produces Intel absolute hex output plus symbols file for use with SID (see below) **\$100/\$15**
- SID** — 8080 symbolic debugger. Full trace, pass count and break-point program testing system with back-trace and histogram utilities. When used with MAC, provides full symbolic display of memory labels and equated values **\$85/\$15**
- TEX** — Test formatter to create paginated, page-numbered and justified copy from source text files, directable to disk or printer **\$85/\$15**
- DESPOOL** — Program to permit simultaneous printing of data from disk while user executes another program from the console **\$50/\$10**

All Microsoft prices are discounted!

MICROSOFT

- Disk Extended BASIC** — Version 5. ANSI compatible with long variable names, WHILE/WEND, chaining, variable length file records **\$300/\$25**
- BASIC Compiler** — Language compatible with Version 5 Microsoft interpreter and 3-10 times faster execution. Produces standard Microsoft relocatable binary output. Includes Macro-80. Also linkable to FORTRAN-80 or COBOL-80 code modules **\$350/\$25**
- FORTRAN-80** — ANSI '66 (except for COMPLEX) plus many extensions. Includes relocatable object compiler, linking loader, library with manager. Also includes MACRO-80 (see below) **\$400/\$25**
- COBOL-80** — ANSI '74 Relocatable object output. Format same as FORTRAN-80 and MACRO-80 modules. Complete ISAM, interactive ACCEPT/DISPLAY, COPY, EXTEND **\$625/\$25**
- MACRO-80** — 8080/Z80 Macro Assembler. Intel and Zilog mnemonics supported. Relocatable linkable output. Loader, Library Manager and Cross Reference List utilities included **\$149/\$15**
- EDIT-80** — Very fast random access text editor for text with or without line numbers. Global and intra-line commands supported. File compare utility included **\$89/\$15**

MICRO FOCUS

- CIS COBOL (standard)** — ANSI '74 COBOL standard compiler fully validated by U.S. Navy tests to ANSI level 1. Supports many features to level 2 including dynamic loading of COBOL modules and a full ISAM file facility. Also, program segmentation, interactive debug and powerful interactive extensions to support protected and unprotected CRT screen formatting from COBOL programs used with any dumb terminal **\$850/\$50**
- CIS COBOL (compact)** — COBOL subset compiler for use on a 32K byte microcomputer. Valuable range of COBOL language features, many at level 2 and including ISAM and the CIS COBOL interactive screen formatting of dumb terminals **\$650/\$50**
- Forms 1** — CRT screen editor to build application CRT forms with protected and unprotected field areas. Output is COBOL data descriptions for copying into CIS COBOL programs. Eliminates the chore of writing screen input and output descriptions by hand and greatly speeds interactive application programming. Output requires CIS COBOL compact compiler **\$125/\$20**

†CP/M for Heath, TRS-80 Model I and PolyMorphic 8813 are modified and must use especially compiled versions of system and applications software.
 ††PolyMorphic 8813 CP/M scheduled for September 15 release.

Software with Manual / Manual Alone

- Forms 2** — Forms 1 screen editor plus indexed file application program generator. Automatically creates a query and update program of indexed files using CRT protected and unprotected screen formats. No programming experience needed. Output program directly compiled by either of CIS COBOL compilers **\$200/\$20**
- EIDOS SYSTEMS**
- KISS** — Keyed Index Sequential Search. Offers complete Multi-Keyed Index Sequential and Direct Access file management. Includes built-in utility functions for 16 or 32 bit arithmetic, string/integer conversion and string compare. Delivered as a relocatable linkable module in Microsoft format for use with FORTRAN-80 or COBOL-80, etc. **\$535/\$23**
- KBASIC** — Microsoft Disk Extended BASIC with all KISS facilities, integrated by implementation of nine additional commands in language. Package includes KISS.REL as described above, and a sample mail list program **\$995/\$45**

All Micropro prices are discounted!

MICROPRO

- Super-Sort I** — Sort, merge, extract utility as absolute executable program or linkable module in Microsoft format. Sorts fixed or variable records with data in binary, BCD, Packed Decimal, EBCDIC, ASCII, floating, fixed point, exponential, field justified, etc. etc. Even variable number of fields per record! **\$225/\$25**
- Super-Sort II** — Above available as absolute program only **\$175/\$25**
- Super-Sort III** — As II without SELECT/EXCLUDE **\$125/\$25**
- Word-Star** — Menu driven visual word processing system for use with standard terminals. Text formatting performed on screen. Facilities for text paginate, page number, justify, center and underscore. User can print one document while simultaneously editing a second. Edit facilities include global search and replace, read/write to other text files, block move, etc. Requires CRT terminal with addressable cursor positioning **\$495/\$25**
- Word-Master Text Editor** — In one mode has super-set of CP/M's ED commands including global searching and replacing, forward and backwards in file. In video mode, provides full screen editor for users with serial addressable-cursor terminal **\$125/\$25**

SOFTWARE SYSTEMS

- CBASIC-2 Disk Extended BASIC** — Non-interactive BASIC with pseudo-code compiler and runtime interpreter. Supports full file control, chaining, integer and extended precision variables, etc. **\$109/\$15**

*CP/M is a trade name of Digital Research.
 **Z80 is a trademark of Zilog, Inc.
 ***UNIX is a trademark of Bell Laboratories.
 ****WHATSI? is a trademark of Computer Headware.

Software with Manual / Manual Alone

Structured Systems prices are discounted!

STRUCTURED SYSTEMS GROUP

- General Ledger** — Interactive and flexible system providing proof and report outputs. Customization of COA created interactively. Multiple branch accounting centers. Extensive checking performed at data entry for proof, COA correctness, etc. Journal entries may be batched prior to posting. Closing procedure automatically backs up input files. All reports can be tailored as necessary. Requires CBASIC **\$899/\$25**
- Accounts Receivable** — Open item system with output for internal aged reports and customer-oriented statement and billing purposes. On-Line Enquiry permits information for Customer Service and Credit departments. Interface to General Ledger provided if both systems used. Requires CBASIC **\$699/\$25**
- Accounts Payable** — Provides aged statements of accounts by vendor with check writing for selected invoices. Can be used alone or with General Ledger and/or with NAD. Requires CBASIC **\$699/\$25**
- LETTERRIGHT** — Program to create, edit, and type letters or other documents. Has facilities to enter, display, delete and move text, with good video screen presentation. Designed to integrate with NAD for form letter mailings. Requires CBASIC **\$179/\$25**
- NAD Name and Address selection system** — interactive mail list creation and maintenance program with output as full reports with reference data or restricted information for mail labels. Transfer system for extraction and transfer of selected records to create new files. Requires CBASIC **\$79/\$20**
- QSORT** — Fast sort/merge program for files with fixed record length, variable field length information. Up to five ascending or descending keys. Full back-up of input files created. **\$95/\$20**

GRAHAM-DORIAN SOFTWARE SYSTEMS

- PAYROLL SYSTEM** — Maintains employee master file. Computes payroll withholding for FICA, Federal and State taxes. Prints payroll register, checks, quarterly reports and W-2 forms. Can generate ad hoc reports and employee form letters with mail labels. Requires CBASIC. Supplied in source code. **\$590/\$35**
- APARTMENT MANAGEMENT SYSTEM** — Financial management system for receipts and security deposits of apartment projects. Captures data on vacancies, revenues, etc. for annual trend analysis. Daily report shows late rents, vacancy notices, vacancies, income lost through vacancies, etc. Requires CBASIC. Supplied in source code. **\$590/\$35**
- INVENTORY SYSTEM** — Captures stock levels, costs, sources, sales, ages, turnover, markup, etc. Transaction information may be entered for reporting by salesman, type of sale, date of sale, etc. Reports available both for accounting and decision making. Requires CBASIC. Supplied in source code. **\$590/\$35**
- CASH REGISTER** — Maintains files on daily sales. Files data by sales person and item. Tracks sales, over-rings, refunds, payouts and total net deposits. Requires CBASIC. Supplied in source code **\$590/\$35**

Software for most popular 8080/Z80 computer disk systems including NORTH STAR, iCOM, MICROPOLIS, DYNABYTE DB8/2, EXIDY SORCERER, SD SYSTEMS, ALTAIR, VECTOR MZ, 8" IBM, HEATH H17 & H89, HELIOS, IMSAI VDP42 & 44, REX, POLYMORPHIC 8813†, OHIO SCIENTIFIC and IMS 5000 formats.

Shopping

Prices and specifications subject to change without notice.

Software
with Manual
Manual / Alone

- tiny C** — Interactive interpretive system for teaching structured programming techniques. Manual includes full source listings **\$75/\$40**
- BDS C Compiler** — Supports most major features of language, including Structures, Arrays, Pointers, recursive function evaluation, linkable with library to 8080 binary output. Lacks data initialization, long & float type and static & register class specifiers. Documentation includes "C" Programming Language book by Kernighan & Ritchie **\$110/\$15**
- Whitesmiths' C Compiler** — The ultimate in systems software tools. Produces faster code than Pascal with more extensive facilities. Conforms to the full UNIX*** Version 7 C language, described by Kernighan and Ritchie, and makes available over 75 functions for performing I/O, string manipulation and storage allocation. Compiler output in A-Natural source. Supplied with A-Natural (see below) requires 60K CP/M **\$630/\$30**
- A-Natural** — Narrative assembler with linking loader, librarian, extensive 8080 subroutine library in A-Natural relocatable format and translators from A-Natural source to Microsoft MACRO-80 source and from A-Natural rel to source **\$330/\$15**
- ALGOL 60 Compiler** — Powerful block-structured language featuring economical run time dynamic allocation of memory. Very compact (24K total RAM) system implementing almost all Algol 60 report features plus many powerful extensions including string handling direct disk address I/O etc. Requires Z80 CPU **\$199/\$20**
- Z80 Development Package** — Consists of: (1) disk file line editor, with global inter and intra-line facilities; (2) Z80 relocating assembler, Zilog/Mostek mnemonics, conditional assembly and cross reference table capabilities; (3) linking loader producing absolute Intel hex disk file. **\$95/\$20**
- ZDT** — Z80 Debugger to trace, break and examine registers with standard Zilog/Mostek mnemonic disassembly displays. Facilities similar to DDT. \$35 when ordered with Z80 Development Package **\$50/\$10**
- DISTEL** — Disk based disassembler to Intel 8080 or TDL/Xitan Z80 source code, listing and cross reference files. Intel or TDL/Xitan pseudo ops optional. Runs on 8080. **\$65/\$10**
- DISILOG** — As DISTEL to Zilog Mostek mnemonic files. Runs on Z80 only **\$65/\$10**
- TEXTWRITER III** — Text formatter to justify and paginate letters and other documents. Special features include insertion of text during execution from other disk files or console, permitting recipe documents to be created from linked fragments on other files. Has facilities for sorted index, table of contents and footnote insertions. Ideal for contracts, manuals, etc. **\$125/\$20**
- Postmaster** — A comprehensive package for mail list maintenance. Features include keyed record extraction and label production. A form letter program is included which provides neat letters on single sheet or continuous forms. Requires CBASIC **\$150/\$25**
- WHATSIT?****** — Interactive data-base system using associative tags to retrieve information by subject. Hashing and random access used for fast response. Requires CBASIC **\$125/\$25**
- XYBASIC** Interactive Process Control BASIC — Full disk BASIC features plus unique commands to handle bytes, rotate and shift, and to test and set bits. Available in Integer, Extended and ROMable versions. Integer Disk or Integer ROMable **\$295/\$25**
Extended Disk or Extended ROMable **\$395/\$25**
- SMAL/80** Structured Macro Assembled Language — Package of powerful general purpose text macro processor and SMAL structured language compiler. SMAL is an assembler language with IF-THEN-ELSE, LOOP-REPEAT-WHILE, DO-END, BEGIN-END constructs **\$75/\$15**
- SELECTOR II** — Data Base Processor to create and maintain single Key data bases. Prints formatted, sorted reports with numerical summaries. Available for Microsoft and CBASIC (state which). Supplied in source code **\$195/\$20**

Lifeboat Associates

2248 Broadway, N.Y., N.Y. 10024

(212) 580-0082 Telex: 668585

Software	Price	
<input type="checkbox"/> manual alone		
<input type="checkbox"/> manual alone		
<input type="checkbox"/> manual alone		
<input type="checkbox"/> Check <input type="checkbox"/> U.P.S. COD <input type="checkbox"/> Visa <input type="checkbox"/> Master Charge	Shipping	
	\$1.00 for C.O.D.	
Exp. Date	Total	
Account #	6	
Signature	Orders must specify disk systems and formats: e.g. North Star single or double density, IBM single or 2D/256, Altair, Helios II, Micropolis Mod I or II, 5 1/4" soft sector (Micro ICOM/SD Systems Dynabyte), etc. Add \$1/item shipping (\$2 min.). Add \$1 additional for UPS C.O.D. Manual cost applicable against price of subsequent software purchase. The sale of each propriety software package conveys a license for use on one system only.	
My computer configuration (specifying disk system):		
Name		
Address (No P.O. Box)		
City	State	Zip

Software
with Manual
Manual / Alone

- SELECTOR III** — Multi (i.e., up to 24) Key version of Selector II. Comes with applications programs including Sales Activity, Inventory, Payables, Receivables, Check Register, Expenses, Appointments, and Client/Patient. Requires CBASIC. Supplied in source code **\$295/\$20**
Enhanced version for CBASIC-2 **\$345/\$20**
- CPM/374X Utility Package** — Has full range of functions to create or re-name an IBM 3741 volume, display directory information and edit the data set contents. Provides full file transfer facilities between 3741 volume data sets and CP/M files **\$195/\$10**
- BASIC UTILITY DISK** — Consists of: (1) CRUNCH-14 — Compacting utility to reduce the size and increase the speed of programs in Microsoft Basic and TRS-80 Basic. (2) DPFUN — Double precision subroutines for computing nineteen transcendental functions including square root, natural log, log base 10, sin, arc sin, hyperbolic sin, hyperbolic arc sin, etc. Furnished in source on diskette and documentation **\$50/\$35**
- STRING BITS** — Fortran character string handling. Routines to find, fill, pack, move, separate, concatenate and compare character strings. This package completely eliminates the problems associated with character string handling in FORTRAN. Supplied with source **\$45/\$15**
- Flippy Disk Kit** — Template and instructions to modify single sided 5 1/4" diskettes for use of second side in single sided drives **\$12.50**

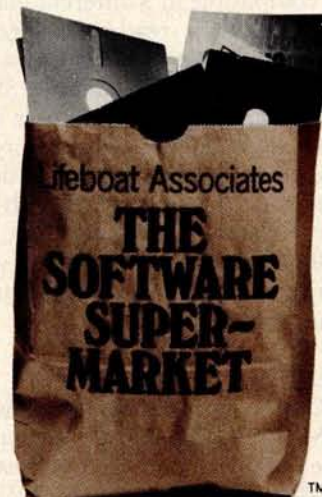

Lifeboat Associates
2248 Broadway
New York, N.Y. 10024

List No. 6

™The Software Supermarket is a trademark of Lifeboat Associates

IBM Compatible Disk Drives

Jefferson H Harman
Director of Research and Development
PerSci Inc
12210 Nebraska Av
Los Angeles CA 90025

In today's expanding market of double-sided, multiheaded, expanded capacity, autoloading, write-protected, floppy disk drives, one requirement remains constant. Virtually all 8 inch floppy disk drives on the market are described as "IBM compatible." (Some of the smaller 5 inch drives are described as IBM compatible even though IBM doesn't manufacture equipment with the smaller drives!) Manufacturers point to it; buyers insist on it; and yet seldom does anyone define what IBM compatibility really means. That is probably because IBM compatibility is not just a single consideration. Three drives described as IBM compatible may, in fact, be compatible in 3 different ways. One drive may be IBM identical with read/write/erase head carriage and all major operating characteristics reverse engineered from an IBM 33FD drive; another drive may accept IBM type 1- or 2-sided single or double density media, but may or may not choose to employ any of the IBM data formats; and finally, a drive may be designed and manufactured with the positioning system drive motor, erase head, and other characteristics different from the IBM drives, but still be able to read and write in the IBM single or double density formats and interchange diskettes with IBM equipment.

Head

One factor does remain constant, however, among the IBM compatible drives. Virtually all of these drives, with one notable exception, bear read/write heads comparable or identical to the IBM drive (figure 1). The advantages to this design decision are clear. Whether or not the IBM design is the most efficient for the purpose does not matter. When the IBM design is employed in an independent manufacturer's drive, it assures that the drive will read back a signal comparable to that of the de facto standard (ie: IBM), thus assuring maximum interchangeability.

Because a majority of floppy disk manufacturers have chosen to remain with the standard, many systems designers must be prepared to deal with the design parameters of the IBM head, a head intended to read and write the IBM soft-sectored formats. The possibilities, limitations, and requirements imposed by this head when formatting data in floppy disk drives are the concern of this article.

Formats

The IBM 33FD head was designed to read and write the IBM soft-sectored formats. Both the drive and the concept of "soft" electronic sectoring were introduced into the marketplace by IBM in the early 1970s on the popular 3740 system. Prior to this introduction, all floppy disk drives (notably IBM's FD23) and virtually all hard disks had been hard sectored (ie: sectors were delineated by physical openings in the media or on an external sectoring device). The new electronic sectoring idea involved prewriting a certain track with track and sector identification data, then later inserting (usually on another machine) the blocks of data to be processed.

As more IBM compatible drives were offered, most users copied the IBM format. That format involves substantial *housekeeping*, and long leader and tail gap lengths; thus the available space for data on a diskette is greatly reduced. The gaps (which in fact are pulses) are used by IBM for 2 reasons: to synchronize the phase-lock loop for the data separator, and to put sufficient time between blocks of data to avoid interference of one block with another. Users were torn; on one hand they wanted more data, while on the other hand they respected the data reliability which was assured by the data bytes used to specify gaps, address marks, cyclic redundancy checks (CRCs), track and sector identification, etc, in the IBM formats. Some users struck out on their own to develop expanded formats.

The IBM formats are examples of the type which must be used with IBM heads in order to assure reliable, high-performance operation. The system engineer may choose to design his own format but, that being the case, will do well to observe the rules outlined below. At PerSci, as manufacturers of IBM compatible floppy disk equipment, we had to develop and use this set of rules. These guidelines are based upon the operating requirements and restrictions of drives with 33FD-type heads. They permit the designer to get the most available data space into the format for any given sector length or number of sectors,

About the Author

Jefferson H Harman is the director of research and development for PerSci Inc, a manufacturer of floppy disk drives.

A 32K MICRO WILL RUN PROGRAMS YOU'D EXPECT ON A MAINFRAME!

And a 64K micro will compile up to 8,000 lines of COBOL . . . and even more if the program is split into dynamically loaded modules or segments.

Its fast too, you compile a 1000 line program in less than 10 minutes. The use of micros for sophisticated business applications has been made possible by our adapting COBOL (the only **universal business language**) to make it easy and effective to use on microcomputers — with special attention to fool-proof conversational working. CIS COBOL is Micro Focus' Compact, Interactive, Standard COBOL which offers the advantages of COBOL (English-like language, powerful data structure features, and existing expertise) to provide a full commercial language for use on microcomputers.

Compact Compiler

The Compact compiler runs on 32K byte microcomputer systems. It offers a powerful subset of ANSI COBOL facilities, including full support for random, indexed, and sequential files. In addition, it gives you all the CIS COBOL features for conversational working, screen control, interactive debugging, and special peripheral support.

Standard Compiler

The Standard CIS COBOL compiler requires a minimum 48K configuration. It is a super-set of the Compact compiler and implements ANSI 1974 COBOL to full Level 1 standard. Among its advanced features are program segmentation and interprogram communication which make it ideal for implementing or converting large systems using modular programming. The same CIS COBOL extensions are available as in the Compact compiler and can be optionally flagged at compile-time so that the compiler then only accepts strict ANSI COBOL.

Because CIS COBOL is a validated ANSI '74 standard COBOL, your applications will be easy to maintain: more professional programmers know COBOL than any other language. And because CIS COBOL conforms fully to the standard, programs written with it are portable — so if you move up to a mini or mainframe, you will be able to take your software with you. Equally, CIS COBOL can enable mainframe COBOL programs and programming tasks to be offloaded to less expensive microcomputers. Mainframe programmers love the ease of use of CIS COBOL and they achieve results fast running it on a desk-top micro.

Environment

CIS COBOL products run on the 8080 or Z80 microprocessors under the CP/M* operating system, and on the LSI-11 or PDP-11 processors under RT-11. They are distributed in a variety of diskette formats, and have a CONFIG utility supplied as standard, enabling you to drive many different types of CRT. All are themselves written in CIS COBOL, and are therefore self-compiling and readily transferable to different operating environments — including new operating systems and new microprocessors. All of which makes CIS COBOL a very attractive proposition for OEMs as well as end-users.

OEMs

A leading semiconductor manufacturer has adapted CIS COBOL for its development systems. We have also supplied CIS COBOL to other OEMs both in Europe and the U.S.A. CIS COBOL was developed entirely by Micro Focus which is therefore ideally placed to support OEMs. If you need COBOL on your system, why don't you call us?

Enquiries for CIS COBOL object packs and application vendor terms either to MICRO FOCUS or its licensed distributors. OEM, dealer, and distributor terms are available on application to MICRO FOCUS.

**CP/M is a trademark of Digital Research Inc*

Forms

The FORMS utility lets you build a screen layout online at the CRT. Then it automatically generates complete COBOL record descriptions for inclusion in your program — saving you time and leaving you free to concentrate on processing.

Forms 2

The FORMS program generator — an extension of FORMS — completely eliminates the need to write simple data entry and enquiry programs. Using it, an entire CIS COBOL source program can be generated automatically from screen definitions — and it works, first time.



CIS COBOL distributors include: Vector Graphic, Lifeboat Associates, Research Machines, Telecomputing, Modular Business Systems and Rair.

MICRO FOCUS

Micro Focus Ltd, 58 Acacia Road, St John's Wood, London NW8 6AG. U.K.
Telephone 01-722 8843. Telex 28536
MICROFG.

What is IBM compatibility?

while at the same time permitting sufficient gap length to maintain data integrity.

Model Format

Table 1 is a model format for data blocks. The maximum number of sectors for any block length, N, can be easily determined by dividing the unformatted data by the total number of bytes per sector.

Using housekeeping techniques different from those shown in the model format, slight variations in the length of a sector can be achieved. For example, the user may choose not to write the cyclic redundancy check on the address field, or may increase or reduce the address marks. The minimum length of leader and tail (trailer), however, are critical, as they are determined from mechanical drive requirements.

The drive characteristics which determine the required leader and tail lengths are:

- Distance from the active part of the read/write head (read/write gap) to the active part of the tunnel erase head (erase gap).
- Variation in linear speed with track locations.
- Timing of erase turn on and off delays.
- Tolerances on these parameters.

As an example, the PerSci drives, which use a head with similar electrical and mechanical characteristics to those used in IBM 33FD disk drives (figure 1), have a distance of 0.036 inch \pm 0.003 inch (0.0914 cm, \pm 0.007 cm) from read/write gap to erase gap. The radius of track 76 is 2.029 inches (5.1536 cm), and the radius of track 00 is 3.612 inches (9.1745 cm). The drive speed is 6 revolutions per second (\pm 2%), and the instantaneous speed variation is \pm 1.5%. PerSci requires a write clock stability of \pm 0.3%.

Unformatted Data Capacity

Unformatted data capacity is determined by dividing the shortest time for a revolution by the longest time for a

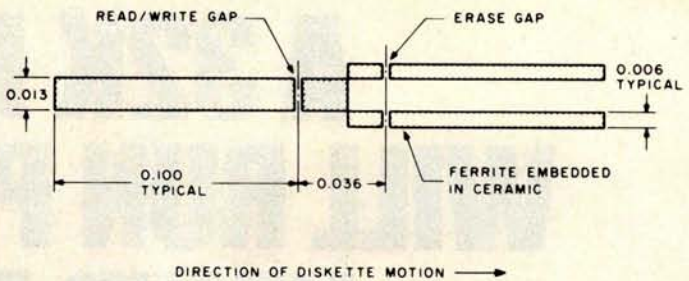

Figure 1: A view of the geometry of the contact surface of a floppy disk read/write head with tunnel erase.

byte. Average speed is used for this calculation since, by definition, average speed is speed averaged over 1 revolution:

$$T = \frac{1}{6 \times 1.02} = 163.399 \text{ ms}$$

$$C = \frac{1}{16 \mu\text{s}/\text{byte} \times 1.003} = 10,208 \text{ bytes}$$

$$C = 10,208 \text{ bytes (modified frequency modulation)}$$

$$C = 5104 \text{ bytes (frequency modulation)}$$

Erase Delays

The read/write head has a gap that is 0.014 inches (0.036 cm) long and thus writes a track greater than 0.014 inches (0.036 cm). After passing under the read/write gap the media next passes under the tunnel erase gaps which clean the area between tracks of any transitions. The tunnel erase also trims 0.001 inches (0.003 cm) from each side of the just written data, reducing the track width to 0.012 inches (0.030 cm). Since a 0.012 inch (0.030 cm) track is read with a 0.014 inch (0.036 cm) head, a misalignment of \pm 0.001 inches (0.003 cm) will cause no degradation of the data. In fact, experimentally, frequency modulated data has been recovered free of errors with deliberate 0.005 inch (0.013 cm) displacement between track center and read head.

The turn-on of the tunnel erase current is delayed from the turn-on of write current to give the disk time to travel from the read/write to the erase gap before tunnel erase begins. To insure that the data is tunnel erased, the

Purpose	Bytes Modified Frequency Modulation (MFM)	Bytes Frequency Modulation (FM)
Address leader (gap)	0.07 (N + 16) + 27	0.07 (N + 10) + 13
Address address mark	1	1
Track identification	1	1
Sector identification	1	1
Address CRC (cyclic redundancy check)	2	2
Address tail (gap)	21	11
Data leader (gap)	12	6
Data address mark	1	1
User data	N	N
Data cyclic redundancy check	2	2
Data tail (gap)	1	1
Unformatted data	10,208	5,104

Table 1: Model format for data block N bytes long. Two columns are shown giving requirements for the 2 different physical modulation formats used. The frequency modulation (FM) format is commonly referred to as "single density." The modified frequency modulation (MFM) format is commonly referred to as "double density."



Something New on the Horizon from Technical Systems Consultants

Extended BASIC for 6800 and 6809

Finally, a BASIC for serious business applications or scientific programming is available. All the features of our regular BASIC are supported—and more. Floating point calculations are carried out to an internal accuracy of 17 digits. Most math functions are accurate to 16 digits with a minimum accuracy of 13.5 digits. Integer variables have been included to allow fast execution of control loops and array indexing. Even with the double precision math package, this BASIC is still one of the fastest around.

The business programmer will appreciate the versatile PRINT-USING capabilities which include dollar and asterisk fill, trailing minus sign, imbedded commas, and scientific notation. New string functions have been added for string searching (INSTR) and for creating a string which is the date (DATES\$). DPEEK and DPOKE are 16-bit peek and poke type functions. The SCALE command has been included to eliminate the round-off errors typically encountered in binary math packages. The INCH\$ function allows single-character input from the terminal. Programmer control of control C breaks is also included.

Overall, the Extended BASIC is the most complete BASIC offered for micro users and is only available on FLEX™ disk. A system with at least 32K of user space is recommended. Specify 8" or 5" media (5" 6800 is FLEX™ 2.0) and either the 6800 or 6809 version when ordering.

AP68-12	6800 Extended BASIC	\$100
SP09-6	6809 Extended BASIC	\$100

BASIC Precompiler

This program allows the creation of BASIC programs without the use of line numbers or restrictive two-character variable names. Alphanumeric line and subroutine labels may be used, as well as variable names of any length. Comment lines are marked with non-alphanumerics for easy readability. The output of the precompiler is in the standard BASIC compiled form. This allows applications programs to be written, precompiled, and then distributed in a non-source form. The precompiler can only be used with one of Technical Systems Consultants' BASICs. Specify 8" or 5" (5" 6800 is FLEX™ 2.0) when ordering.

AP68-13	Single Precision 6800 Precompiler	\$40
AP68-14	Double Precision 6800 Precompiler	\$50
SP09-7	Single Precision 6809 Precompiler	\$40
SP09-8	Double Precision 6809 Precompiler	\$50

FLEX is a registered trademark of Technical Systems Consultants, Inc.

 **technical systems
consultants, inc.**

Box 2570, West Lafayette, IN 47906
(317) 463-2502

longest turn-on delay must be shorter than the shortest time to travel from read/write to erase gap. This may be calculated in the following manner:

$$\begin{aligned} \text{Maximum Linear Speed} &= \text{MLS} \\ \text{MLS} &= 6 \text{ revolutions/second} \times 1.035 \times \frac{2 \pi \text{ radians}}{\text{revolution}} \\ &\quad \times \frac{3.612 \text{ inches}}{\text{radian}} \end{aligned}$$

$$\begin{aligned} \text{MLS} &= 140.9 \text{ inches/second} \\ \text{MLS} &= 357.9 \text{ cm/second} \end{aligned}$$

The minimum time is then given by:

$$\begin{aligned} \text{Te Min} &= \frac{\text{Minimum Spacing}}{\text{MLS}} \\ \text{Te Min} &= \frac{0.036 \text{ inches} - 0.003 \text{ inches}}{140.9 \text{ inches / second}} \\ \text{Te Min} &= 234.1 \mu\text{s} \end{aligned}$$

$$\text{Erase Delay Short} = 234.1 \mu\text{s}$$

$$\text{Nominal} = \frac{234.1 \mu\text{s}}{1.1}$$

$$\begin{aligned} \text{ED} &= 213 \mu\text{s} \\ \text{ED Min} &= 213 \times .9 \\ \text{ED Min} &= 191.6 \mu\text{s} \end{aligned}$$

Similarly, the erase turn-off delay must be longer than

the longest time for the disk segment to travel from the read/write to the erase gap:

$$\begin{aligned} \text{Slowest Linear Speed} &= \text{SLS} \\ \text{SLS} &= \text{Minimum Angular Speed} \times \text{Minimum Radius} \\ &= 6 \text{ revolutions/second} \times (.965) \frac{2 \pi \text{ radians}}{\text{revolution}} \\ &\quad \times \frac{2.029 \text{ inches}}{\text{radian}} \end{aligned}$$

$$\begin{aligned} \text{SLS} &= 73.82 \text{ inches/second} \\ \text{SLS} &= 187.50 \text{ cm/second} \end{aligned}$$

Maximum time to travel from read/write to erase gap is given by:

$$\begin{aligned} \text{Te Max} &= \frac{\text{Maximum Spacing}}{\text{SLS}} \\ &= \frac{0.036 \text{ inches} + 0.003 \text{ inches}}{73.82} \end{aligned}$$

$$\begin{aligned} \text{Te Max} &= 5.28 \mu\text{s} \\ \text{Minimum TurnOff Delay} &= 528.3 \mu\text{s} \\ \text{Nominal TurnOff Delay} &= 587 \mu\text{s} \\ \text{Maximum TurnOff Delay} &= 646 \mu\text{s} \end{aligned}$$

Address Block Tail

The address block is written when the disk is formatted, and is rewritten only if the disk is reformatted. The format operation generally writes an entire track at one pass, completely filling the unused areas with an arbitrary pattern. User data blocks are then inserted between address blocks. The turn-on of write current when writing a user data block is timed from the address block clock; therefore, the address block will not be overwritten by the start of a data block. However, sufficient tail must be provided to prevent the erase current from being turned on during the meaningful data in the address block. If it was turned on, each successive write (assuming track alignment between writes shifts slightly) would trim away some of the address block, thus degrading data reliability until errors occurred. The tail required to prevent this occurrence is found by subtracting the quickest erase turn-on from the maximum time to travel from the read/write to erase gap:

$$\begin{aligned} \text{Address Field Tail} &= \text{TAB} \\ \text{TAB} &= \text{Te Max} - \text{ED min} \\ \text{Tab} &= 528.3 \mu\text{s} - 191.6 \mu\text{s} = 336 \mu\text{s} \end{aligned}$$

This 336 μs will occur at *slowest* drive speed; but the write clock could be maximum. Therefore the address tail is given by:

$$\frac{336 \mu\text{s}}{16 \mu\text{s} \times 0.997 \times 1.035} = 20.35 \text{ bytes}$$

Use 21 bytes, since partial bytes are not conveniently written.

Data Block Tail

An address block is never inserted after a data block. Therefore, the only requirement for a tail on the data



We've hatched a nestful of new tiny-c products.

Now you can really expand your horizons with the tiny-c structured programming language. The tiny-c owner's manual (including 8080 and PDP-11 source code and tiny-c in C) is still just \$40. And we've added these new formats to really egg you on: TRS-80 Level II SYSTEM Format Cassette; CP/M Diskettes with 8080 Source; PDP-11 Diskette; North Star 5" Diskette; KIM and SYM cassettes. And there's more, all available for \$50 or less. Order your tiny-c owner's manual today and get the whole story. Call or write: tiny c associates, P.O. Box 269, Holmdel, N.J. 07733.

(201) 671-2296.
You'll quickly discover tiny-c is all it's cracked up to be.

New Jersey residents include 5% sales tax. Visa and MasterCard accepted. Include charge plate number with order.

tiny
C



BUY ONE of these great professional books and GET ONE FREE

(VALUES UP TO \$38.95)

when you join the
**COMPUTER PROFESSIONALS'
BOOK CLUB**

What is the COMPUTER PROFESSIONALS' BOOK CLUB?

Call it an insurance policy against obsolescence! A lot of our members do.

McGraw-Hill's Computer Professionals' Book Club can be your most important line to the fast-breaking changes and revolutionary ideas sweeping the computer science field today. CP is not just another book club. It comes from one of the world's foremost technical publishers. And it provides only the hard, to-the-point information you need *now* to stay ahead tomorrow.

CP helps you save! By searching out only the best in essential literature from dozens of publishers, and buying in large, money-saving quantities, CP passes on big savings to you. Many members find they save 20-30% on what they would pay otherwise—and that's not including the 100% savings on the free book you get when you join the Club.

CP gives you an instant review of the field! Fourteen times a year you receive free of charge the *Computer Professionals' Book Club Bulletin* describing the featured book of the month, along with outstanding alternate selections. Considering the many books published annually, you can bet there'll be some of special interest to you. You'll see at a glance what's new—and receive only the books you want to own!

- 168/075
AUTOMATIC DATA PROCESSING HANDBOOK
edited by The Diebold Group, Inc.
Pub. Price, \$38.95 Club Price, \$25.75
- 786/81X
COMPUTER ALGORITHMS: Introduction to Design and Analysis
by S. Baase
Pub. Price, \$17.95 Club Price, \$14.75
- 654/158
PROGRAMMING LANGUAGES
by A. B. Tucker, Jr.
Pub. Price, \$22.00 Club Price, \$16.50
- 787/026
MINICOMPUTER SYSTEMS, 2nd Ed.
by R. H. Eckhouse
Pub. Price, \$21.95 Club Price, \$17.75
- 771/499
MICROCOMPUTERS/MICROPROCESSORS: Hardware, Software and Applications
by J. L. Hilburn & P. N. Julich
Pub. Price, \$22.50 Club Price, \$16.50
- 786/380
FUNDAMENTALS OF COMPUTER ALGORITHMS
by E. Horowitz & S. Sahni
Pub. Price, \$19.95 Club Price, \$15.95
- 333/874
MICROPROGRAMMING PRIMER
by H. Katzan, Jr.
Pub. Price, \$20.95 Club Price, \$15.70

- 435/278
MICROPROCESSOR APPLICATIONS MANUAL
by Motorola, Inc.
Pub. Price, \$38.00 Club Price, \$26.50
- 491/380
MICROCOMPUTER-BASED DESIGN
by J. Peatman
Pub. Price, \$26.50 Club Price, \$18.95
- 701/30X
DATA BASE DESIGN
by G. Wiederhold
Pub. Price, \$24.50 Club Price, \$18.25
- 463/387
PRINCIPLES OF INTERACTIVE COMPUTER GRAPHICS, 2nd Ed.
by W. M. Newman & R. F. Sproull
Pub. Price, \$19.95 Club Price, \$14.95
- 785/49X
PROGRAMMING FOR MINICOMPUTERS
by J. C. Cluley
Pub. Price, \$17.50 Club Price, \$13.50
- 786/372
REAL-TIME PROGRAMMING WITH MICROCOMPUTERS
by R. C. Turner
Pub. Price, \$16.95 Club Price, \$13.95
- 191/549
MEMORY DESIGN: Microcomputers and Mainframes
by Electronics Magazine
Pub. Price, \$18.50 Club Price, \$15.50

MAIL THIS COUPON TODAY

COMPUTER PROFESSIONALS' Book Club
P.O. Box 582, Hightstown, New Jersey 08520



Please enroll me as a member and send me the two books indicated. I am to receive one free book plus my first selection at the discounted price to members, plus local tax, postage and handling. If not satisfied, I may return the books within 10 days and request that my membership be canceled. If I keep the books, I agree to take a minimum of three additional books during the next two years. I will receive the Club Bulletin 14 times a year. If I want to examine a featured selection, I need take no action. It will be shipped automatically. If I want an alternate selection—or no book at all—I will notify the Club by returning the card enclosed. A postage and handling charge is added to each shipment. I will have a minimum of 10 days in which to return the card, and you will credit my account fully, including postage, if this is not the case. Membership in the Club is continuous but cancellable by me at any time after the four-book purchase requirement has been fulfilled.

This order subject to acceptance by McGraw-Hill.

Write Code # of
FREE selection here

Write Code # of
FIRST selection here

Orders from outside the U.S. must be prepaid with international money orders in U.S. dollars.

Charge my VISA MASTER CHARGE* Exp. Date _____

Credit Card # _____ *MC Bank # _____

Signature _____

Name _____

Address _____

City, State, Zip _____

block is for a bit to guard the cyclic redundancy check from being at a boundary between old and new data. Use 1 byte.

Data Block Leader

The data block is always written later than the address block. Therefore, enough leader to synchronize the data separator is all that is necessary. The PerSci data separator will lock to frequency in 100 μ s on any pattern and then requires 4 successive 0s to determine that the input data is clock pulses. This would require 4 bytes in frequency modulation forms. The IBM formats require 6 bytes of 0s for frequency modulation or 12 bytes of 0s for modified frequency modulation.

Address Block Leader

The address block leader must be long enough to guard against the possibility of the inserted data block of the earlier sector overwriting meaningful data; as well as being additionally long enough to prevent the erase turn-off of that inserted data block from degrading meaningful address data. Since even degraded data should be good enough to synchronize the data separator, the sum of the bytes required for the first 2 effects is all that is required. Longest erase delay minus shortest time to travel from read/write to erase gap:

$$\begin{array}{r} 646 \mu\text{s} - 234.1 \mu\text{s} \\ = 412 \mu\text{s} \\ \hline 412 \mu\text{s} \\ \hline 16 \mu\text{s}/\text{byte} \times 0.965 \times 0.997 \\ 27 \text{ bytes double density} \\ 14 \text{ bytes single density} \end{array} = 26.8 \text{ bytes}$$

To absorb the effect of speed variation between format and writing, a gap of the maximum difference in time for

a data block must be allowed. A data-block double density will consist of 12 bytes of leader, 1 byte address mark, N bytes of user data, 2 bytes of cyclic redundancy check, and 1 byte of tail. This is N + 16 bytes.

Longest block time, with $\pm 3.5\%$ speed variation:

$$1.035 \times (N + 16) \text{ bytes}$$

Shortest Block:

$$0.965 (N + 16) \text{ bytes}$$

$$\begin{aligned} \text{Difference} &= (1.035 - 0.965) (N + 16) \\ &= 0.07 (N + 16) \text{ bytes} \end{aligned}$$

The address field leader must then become the sum of these:

$$\begin{aligned} \text{AFL} &= 27 + 0.07 (N + 16) \text{ modified frequency} \\ &\quad \text{modulation} \\ &= 13 + 0.07 (N + 10) \text{ frequency modulation} \end{aligned}$$

This leader must be terminated with enough successive 0s to synchronize the data separator.

Conclusions

The formatting rules outlined above allow for the mechanical variations of the floppy disk drive; the user can design a format to give maximum data capacity with maximum reliability. If these rules are not followed, however, the format will cause a slow degradation of the address each time a new block of user data is inserted, until the address is not readable. It is a simple matter then (with a little planning) to maintain *compatibility* with your IBM head, thus assuring the success of your non-IBM format. ■

S-100 USERS: GIVE YOUR COMPUTER THE GIFT OF SIGHT!

The DS-80 Digisector® is a random access video digitizer. It works in conjunction with a TV camera (either interlaced or non-interlaced video) and any S-100 computer conforming to the IEEE standards. Use it for:

- Precision Security Systems
- Moving Target Indicators
- Computer Portraiture
- Fast To Slow Scan Conversion
- Robotics
- Reading UPC Codes, schematics, paper tape, musical scores



● IMAGE PROCESSED BY DS-80 ●

CHECK THESE FEATURES:

- High resolution** — a 256 x 256 picture element scan
- Precision** — 64 levels of grey scale
- Speed** — Conversion time of 14 microseconds per pixel
- Versatility** — scanning sequences user programmable
- Economy** — a professional tool priced for the hobbyist; comes fully assembled, tested and burned in, with fully commented portrait printing software.

Price: \$349.95 MasterCharge and Visa

THE MICRO
WORKS

P.O. BOX 1110, DEL MAR, CA 92014 714-756-2687

BYTE News . . .

THE S-100 BUS - WHAT IS ITS FUTURE?: Some industry pundits have speculated that the S-100 bus was doomed when integrated machines like the TRS-80, PET, Apple, et al, were introduced. I do not agree with this view.

There are now an estimated 200,000 S-100 systems in operation, and S-100 system sales should continue strong for a number of reasons.

The S-100 bus is not processor dependent. In fact there are presently 8080, Z80, 8085, 6502, 6800, 6809, 9900, 8086, Z8000 and MCP1600 processor boards that plug into the S-100 bus. The 68000, when it becomes available, will surely be adapted for the S-100 bus also.

It allows for extended addressing beyond 64 K bytes of memory. In fact the 16-bit microprocessors on the S-100 bus employ up to 23-bit address words and can access directly up to 2 M bytes of memory. The 8-bit microprocessors can accomplish a similar feat by a bank-switching arrangement. The Institute of Electronic and Electrical Engineers (IEEE) is adopting an S-100 standard, which should eliminate signal and timing problems and encourage sophisticated 16-bit systems.

The S-100 bus has a lot of other goodies such as vectored interrupt, direct memory access (DMA), and master/slave capabilities, which are not possible on the limited bus structures of machines such as the TRS-80, PET, APPLE, etc.

At least 3 new S-100 mainframes have been introduced so far this year. These newer boxes are capable of operating at speeds up to 10 M Hz, have larger power supplies and other features.

Those who wish to have a machine capable of getting the maximum benefits of microprocessors must go the S-100 route. The S-100 bus will thus continue to dominate the serious personal computing area for many years to come.

NEW IMAGE SENSOR USES PHOTODIODE ARRAY: An integrated circuit consisting of a 64 by 64 array of 4096 photodiodes with associated registers and accessing circuitry has been developed for video camera use. The manufacturer, Integrated Photomatrix Inc, Mountainside NJ, claims that it can produce video-quality gray scale images with illumination as low as 60 foot candles. This is 5 to 8 times more sensitive than previous devices. However, the most important feature is that it lends itself to computer processing.

RANDOM NEWS: Atari has received FCC approval for their model 400 and 800 personal computers. This will probably make the FCC less willing to grant the Texas Instruments request for changes in the rules, as the FCC finds that other companies are able to pass current requirements . . . Radio Shack will open 100 Computer Sales Departments in 100 existing stores, in addition to the 50 Radio Shack Computer Centers already in operation . . . Two pioneer personal computer companies have shut their doors and are out of business. They are Processor Technology Company and Xitan Inc (formerly TDL). Their closings are attributed to poor business management, not lack of business.

RANDOM RUMORS: Shugart is about to announce an 8 inch Winchester disk drive for under \$1000. Rumor is that it will be called the Model SA-1000 and will store 5 M bytes. In original equipment manufacturer (OEM) quantities it may sell for as little as \$750 . . . 5¼ inch Winchester-type drives are being investigated by several manufacturers . . . Digital Equipment Corporation's Computer Stores are proving to be a real success. Four stores are already in operation and 6 more are planned to be opened by the year's end. The stores will sell computers in the \$12,000 to \$18,000 range with supplies and accessories aimed at small business users . . . A record 78,843 people attended the National Computer Conference (NCC) held in New York City this past June. This was 22,000 more than last year, which also set a record . . . Sinclair Radionics Ltd, London, England, has demonstrated a flat screen (3 inch) black and white television receiver, the size of a paperback book. They are now looking for financing for the production of the unit. This may be the forerunner of the pocket computer terminal.

PERSONAL COMPUTER TIMESHARE NETWORK INAUGURATED: Telecomputing Corporation of America, McLean Va, has started a Personal Computer Network which may be accessed by home users with terminals or personal computer systems. They have about 2000 programs and data bases on-line for immediate access. Included is the United Press International (UPI) daily news file, airline schedules and real estate listings. Called "The Source", the service will be available in 200 US cities at \$2.75 per hour from 6 PM to 7 AM, weekends and holidays. The rate during normal working hours will be higher.

DYNAMIC MEMORY AND THE "SOFT ERROR": As programmable memory size increases and memory cell size decreases, users are discovering that programmable memory can have *soft errors* as well as *hard errors*. A *hard error* is when a bit or bits in a given memory location is *stuck* high or low. This kind of error is easily found with a memory test and always has the same effect on the processor.

The introduction of very large-scale integration (VLSI) dynamic-memories with very small cell size has introduced soft errors which cause varying symptoms in the running of a program. A *soft error* is defined as a random, nonrecurring, bit change. The occurrence of soft errors appears to be on the increase and standard memory tests do not appear to help in diagnosing the problem.

The integrated circuit (IC) industry is becoming very concerned with the growing problem. Several integrated circuit makers have intensive research going on to discover the sources of the problem. The chief cause appears to be alpha particle radiation produced by the radioactive trace elements in the metal lids which hermetically seal the integrated circuit cavity. Several measures are being adopted by integrated circuit makers including package redesign, processing changes, and recommending that users employ error correction schemes in their memory boards to cope with the problem.

LEAVE THE DRIVING TO THE MICROCOMPUTER: Several automobile makers have research and development programs aimed at developing computer controlled cars. An example is the LISA system now under development by Volkswagen. A small console will be located on the car's dashboard. It will have a small keyboard, graphics and alphanumeric display controlled by a microprocessor. The driver will key in the code for the town he or she wishes to go to. Then as the car passes over sensor cables imbedded in the road, LISA's microcomputer transmits the car's destination to a master computer and receives instructions on the fastest and least congested route. LISA then displays a map showing the driver where to turn. LISA can be extended to control the car's speed from the information received from the master computer and an on-board radar system. Pretty soon, you will get into your car, buckle your seat belt, turn on the ignition and "leave the driving to LISA."

16-BIT MICROPROCESSORS TO DOMINATE THE 1980s: Most industry experts feel that the dominant microprocessor in personal computing and small business applications will be the 16-bit processor. They feel that prices will drop sharply, substantially reducing the price difference between 8-bit and 16-bit microcomputer systems. 8-bit microprocessors are expected to remain strong into the early 1980s because of the strong software base and significantly lower cost. However, the situation is expected to change by the mid-1980s with the 16-bit processor becoming dominant.

1980 should see at least a dozen 8086 and Z8000 processor and memory cards for the S-100 bus. The Motorola 68000 16-bit entry should make its appearance in personal computing systems by late 1980. It is interesting to note that Motorola in designing their new microcomputer development system are introducing a new Polybus which is upgradable to 32-bit service.

NONIMPACT PRINTERS IMPROVING: Considerable research is being devoted to the improvement of nonimpact printers. These efforts should bear fruit within the next 5 years, and will probably result in higher print quality, increased printing speed and greater capabilities. It is expected that quality will improve to produce type quality equal to Selectric and Diablo type printers. Speed will increase dramatically: 12,000 lines per minute will be common. Further, the printers will have multifont and graphics capabilities. Hence, they will simultaneously print the forms and the data, and put in signatures as well. Also, they will be capable of producing half-tone graphics and some even capable of multicolor printing.

LASER DISK MEMORY SYSTEMS IN DEVELOPMENT: At least 3 companies, Sperry Univac, Nippon Electric Co Ltd and Phillips Research Laboratories, are known to be working on laser disk-type data storage systems. Referred to as optical disks, they employ diode-laser recording systems which can record alphanumeric and image data on tellurium coated disks. They will be capable of substantially greater bit density than present magnetic disks.

PASCAL BEING PUSHED: More and more computer manufacturers are jumping on the Pascal bandwagon. Recently, Digital Equipment Corporation, Data General and Texas Instruments introduced packages for their mini and microcomputer systems. Pascal packages have also been introduced for CPM, North Star, Radio Shack TRS-80 and Apple computers.

Sol Libes
ACGNJ
1776 Raritan Rd
Scotch Plains NJ 07076

MAIL: I receive a large number of letters each month, as a result of this column. If you write to me and wish a response, please include a stamped self-addressed envelope.

SYNCHRO-SOUND

The ORIGINAL Computer People Who KNOW computers and offer EVERYTHING you need in Small Computer Systems

Compare PRICE, QUALITY, DELIVERY, SERVICE and you'll see why you don't have to look anyplace else!



TEXAS INSTRUMENTS
810 Multi-Copy Impact Printer
ONLY **\$1599.00**
SINGLE QUANTITY PRICE

We carry a full line of Texas Instruments products

SUPER SPECIAL!



LA 34
DECwriter IV Teleprinter
\$1095.00
SINGLE QUANTITY PRICE

TERMINALS

LEAR-SIEGLER ADM-3A...
ADM-31...
ADM-42... } **CALL*** for prices



HAZELTINE 1400...
1410...
1500...
Mod 1 Edit... } **CALL*** for prices

PRINTERS

QUME Sprint—5/45 KSR
..... **\$2995.00**
Typewriter Quality Printer Terminal



COMPUTERS

NORTHSTAR Horizon II (kit)..... **CALL*** for price



DIGITAL SYSTEMS

DSC-2.....
Dble Density Dual Drive Disk..... } **CALL*** for prices



TELETYPE

43..... **CALL*** for price



CROMEMCO System 3..... **CALL*** for price



CENTRONICS

Micro.....
779-2..... } **CALL*** for prices
700-2.....
703-0.....



MORE SPECIALS

Okidata SL 125	\$1595.00	44 Column Printer	\$295.00
Qume Sprint 5/45 RO	2795.00	Livermore Acoustic Coupler	249.00
Persci 277 Dble Density	1395.00	Javelin 9" Monitor	159.95
Imsai PCS 80/15	599.00	Centronics Micro Printer	395.00
Anadex DP 8000 Printer	995.00		

* Our prices are too low to advertise. Please call or write. We now carry a full line of Alpha-Micro Products

We have a full staff of Programmers and Computer Consultants to design, configure and deliver a Turnkey Computer System to meet your specific requirements.



SYNCHRO-SOUND ENTERPRISES, INC.

The Computer People
193-25 Jamaica Avenue, Jamaica, New York 11423
TWX 710-582-5886

PHONE ORDERS, CALL:
NEW YORK — 212/468-7067
LOS ANGELES — 213/628-1808
CHICAGO — 312/641-3010
DALLAS — 214/742-6090

Finally, a computer breakthrough that really is a breakthrough!



THE SOURCE is here... the first time-sharing information system devised for home and small business computing!

Now, for the first time in history, you can link your personal computer to a vast, powerful information system that extends to hundreds of major U.S. cities and puts you in control of more than 2,000 different information resources and programs—*for just pennies a minute!*

Pioneered by the Telecomputing Corporation of America, this breakthrough is called THE SOURCE Information Utility, and it is revolutionizing the world of personal computing!

Large system capability from the hardware you're using now!

Any personal computer with a modem can be hooked up to THE SOURCE quickly and easily. Just dial a local phone number and key in your private password, and you'll have the large system capability you've always wanted at a fraction of the usual cost!

THE SOURCE is yours for as little as \$2.75 an hour (4.6¢ a minute)—No CPU charges!

You can access the wealth of information resources and programs in THE SOURCE for an hourly charge of just \$2.75 during non-prime hours*, plus a one-time hookup fee of \$100.00. TCA also provides intelligent terminal software for an additional \$25.00. Your connect time will be automatically recorded by THE SOURCE in one-minute increments and billed to the major credit card account of your choice.

* Non-prime hours are 6 p.m. to 7 a.m. (local time) Monday through Friday, and all day Saturday, Sunday and holidays. Non-prime connect time is \$2.75 an hour. The prime time usage charge is \$15.00 an hour. There is a minimum monthly charge of \$5.00 and disk storage charges are calculated at .033 cents/2,048 character block/day.

Thousands of new capabilities at your fingertips!

Whether you use your personal computer for business, entertainment, education or just plain fun, THE SOURCE will broaden your horizons in any category with thousands of informative, easy-to-use application programs and special system features to benefit every member of your family.

Here's just a quick look at some of the far-reaching capabilities you'll command from your home or office with THE SOURCE!

Electronic Mail

You can send point-to-point or multi-point electronic messages all over the country with THE SOURCE. Just think, now you can exchange software electronically, without regard for the lack of cassette and diskette standards. On the job, you can receive and send important messages instantly, handle information at your convenience, cut down on interruptions and save the time and money of long distance phone calls or letters. THE SOURCE's exclusive *Datapost* service lets you send hard copies of your messages for just pennies apiece—with overnight delivery.

Chatting

Use THE SOURCE to "chat" electronically with friends or business associates in a real time interactive

mode. And you can chat with other SOURCE users all over the country for considerably less than the cost of a long-distance phone call.

Easy To Use

You and THE SOURCE will easily understand each other because all programs and data bases are organized under a unique "key word" indexing system that gives you exactly the information you need in seconds.

Write your own programs . . .

You get all the advantages of timesharing, including complete programming capability in such languages as extended BASIC, FORTRAN IV, PASCAL, Assembly and many more. And you'll have at your command THE SOURCE's powerful text editor and cross assemblers for all popular micro-processors.

. . . Or choose from over 2,000 existing data bases and application packages!

THE SOURCE gives you instant access to an almost unlimited variety of data base information resources and programs that you and your family can use to live better, work better, study better and have more fun. You can turn to THE SOURCE for:

- **News, sports, weather, financials** and features from United Press International's worldwide news service.
- **Major stock exchange information**, including stock market averages, closing statistics, news, quotations and summaries, plus trends and extensive historical data on the market activity of 3400 publicly traded stocks.
- **A library of educational courses** and reviews from kindergarten to post-grad level, including the Dartmouth College educational library.
- **New York Times Consumer Data Bank**, an extract service of over 5,000 topical items appearing in major publications—a powerful and prestigious information and research tool!
- **Entertainment and hobbies**, including theatre and restaurant guides, movie and book reviews, concert and ticket information, and tips on dozens of hobbies

from auto repair to gourmet cooking, plus daily horoscope and biorhythm reports and scores of electronic games for all age levels and interests.

- **Financial information**, including a complete income tax guide, home financial planning, investment assistance, a national real estate buying and selling service, and much more!
- **Business help**, including a complete set of basic business accounting packages, a proven business data base management system, and hundreds of parameter-driven application packages for users in scientific, engineering, government and education fields.
- **Personal and business travel planning**, including airline schedules, reservation and ticket confirmations, plus hotel/motel and car rental reservations.

Available now in 250 major U.S. cities and growing!

When you subscribe to THE SOURCE, you get more than power, you get *reach!* THE SOURCE is now available in over 250 major U.S. cities and the network is growing!

Hook up to THE SOURCE now!

For a one-time hookup fee of just \$100.00, you will get a complete SOURCE Users Guide, a personal TCA identification number and a private password that will deliver the vast information power of THE SOURCE Information Utility to your personal computer.

Don't wait another day to discover the awesome capabilities of THE SOURCE! Complete the order form below *now*, indicating the credit card account to which you would like the service billed. MAIL IT TODAY TO:



Telecomputing Corporation of America
1616 Anderson Road
McLean, Virginia 22102

Give your personal computer the large system information power and communications reach of THE SOURCE—Send this coupon today!

© 1979 Telecomputing Corporation of America

Mail to: Telecomputing Corporation of America
1616 Anderson Road, McLean, Virginia 22102

Yes! Give my personal computer the power of THE SOURCE Information Utility! Please send me my personal TCA identification number, private password and complete User's Guide. I understand that my monthly connect charges (\$2.75/hr. for non-prime use, \$15/hr. for prime time use) will be billed to the account I have indicated. I also understand that I am subject to a \$5.00 minimum monthly charge.

Check one:

- Please charge the account indicated in the amount of \$100 for hookup to THE SOURCE Information Utility.
- Please charge the account indicated in the amount of \$125, which includes hookup to THE SOURCE Information Utility and TCA's intelligent terminal software package. My system configuration is:

Manufacturer: _____
Model # and Description _____
Specific Configuration _____

Credit Card Information (please complete)

VISA MASTER CHARGE AMERICAN EXPRESS

Account #: _____ Exp. Date: _____

Name _____

Address _____

City _____

State _____ Zip Code _____

Signature _____ Date _____



The information innovation you've been waiting for!

B/O

“onComputing™ really makes personal computers easy to understand.”



Written in non-technical language, onComputing™ contains articles on the capabilities of microcomputers, getting started, latest reviews of personal computers, where to purchase and how to use your computer.

An anyone can learn the fundamentals of using a computer. **onComputing** readers receive practical advice and helpful hints on how to get the most out of a personal computer, explanations of computer terminology, and, periodically, an updated list of active computer clubs.

Benefit from the experience of other computer enthusiasts. Articles in **onComputing** are written by well known authors as well as competent amateurs. They share their ideas on how to use the computer as a tool for business, education, home entertainment, laboratory work and other applications.

Computer experts edit **onComputing** for the new user, not the computer professional. The editors combine their esoteric knowledge of computer science and equipment to produce concise, non-technical material which can be readily understood by anyone interested in using a computer— for fun or profit.

onComputing, Inc.
70 Main St., Peterborough, NH 03458

Start your subscription today.

EVERY THREE MONTHS **onComputing** will bring the latest developments in the field of personal computing: use, applications, books, selection—all in an easy-to-read style.

onComputing Subscription Dept. P.O. Box 307, Martinsville, NJ 08836

REGULAR subscription rate:

- U.S. 1 yr. (4 issues) @ \$8.50
- Canada & Mexico, 1 yr. (4 issues) @ \$10.00
- FOREIGN (to expedite service, please remit in U.S. funds drawn on a U.S. bank.)
- Europe (and all other countries, except above), 1 yr. @ \$12.00—surface delivery.
- Start my subscription with current issue. Start with Vol. 1 No. 1
- Bill Visa Bill Master Charge Bill me (North America only)

Card Number _____

Expiration _____

Signature _____

Name (please print) _____

Street/Apartment Number _____

City _____

State/Province/Country Code _____

The TRS-80 Speaks

Using BASIC to Drive a Speech Synthesizer

Tim Gargagliano
Kathryn Fons
24121 Mound Rd
Warren MI 48091

The rapidly increasing family of Radio Shack TRS-80 computer peripherals has recently acquired a voice synthesizer module. Any application of this computer system which involves human interaction can be improved with the addition of computer voice response. Voice can be used as a supplement to the video display or printer (by repeating what has been printed) or used alone when it is undesirable to print (such as for intermittent feedback while printing a long task). A few of the applications of the verbal peripheral are games, clocks, verbal prompting, alarm systems, doorbells, computer-aided instruction, and a blind user's terminal. The intent of this article is to present an overview of the voice synthesizer as a TRS-80 peripheral and to demonstrate the ease with which TRS-80 applications software can be modified to include the voice unit.

Based on electronic *phoneme synthesis*, the voice response system synthesizer is capable of producing virtually any English language word and subsets of many foreign languages. Word production is achieved by sequencing the units of sound produced by the synthesizer, referred to as phonemes. The synthesizer, developed and manufactured by the Votrax Division of Federal Screw Works, produces 62 electronic phonemes. Procedures for sequencing phonemes are discussed in the Phonetic programming section.

The advantage of phoneme synthesis over other forms of speech production is its low data storage requirement. The average data transfer rate is 100 bps. Another advantage resulting from this low data rate is the negligible processor overhead associated with control of the synthesizer. This allows the computer to execute other tasks while it is generating speech. From a memory requirement standpoint, there are not any cumbersome software drivers or data tables.



Photo 1: Radio Shack TRS-80 computer system with the voice synthesizer module sitting on top of the video monitor.

Users of the TRS-80 Level I BASIC will be happy to learn that the voice synthesizer will interface with it, without any hardware modifications. This is possible by use of a special PRINT statement as an output command. (Level I BASIC does not have output commands to any device except the video display and cassette tape drive.) Level II and Disk BASIC users may also use POKE commands to drive the synthesizer.

Device Description

The TRS-80 voice synthesizer is packaged in a silver-gray cabinet with a black front grill, slightly resembling a speaker enclosure. There is a volume control and device select indicator on the front panel next to a speaker. A ribbon cable emerges from the back of the cabinet, and connects directly to the TRS-80 microcomputer keyboard module, or to the screen printer port on the expansion interface. Its length is sufficient to allow the cabinet to be placed on top of the TRS-80 video display unit.

Phonetic Programming

Phonetic programming is the operation performed to construct

About the Authors

Tim Gargagliano and Kathryn Fons are employees of the Federal Screw Works, and work in the research and development laboratory.

TRS-80 SOLUTIONS!

Appointment Log		\$9.95
Payroll	Disk	\$59.95
Mail List I	Disk	\$19.95
Mail List II	Disk	\$99.95
Small Business Bookkeeping		
w/ journal		\$22.00
w/o journal		\$15.00
Small Business Bookkeeping For Disk		
w/ journal		\$31.95
w/o journal		\$24.95
Inventory S	Tape - \$24.95	Disk \$39.95
Electric Pencil		Disk \$150.00
Accounts Receivable II		Disk \$79.95
Inventory System 2.3	32K 2-disk	\$79.95
Periodical Cross Ref.	Tape \$14.95	Disk \$19.95
8080-Z80 Conversion		\$15.00
Basic Statistics		\$20.00
ST80 Smart Terminal		\$49.95
ST80D	Disk	\$79.95
Newdos 3.0		\$49.95
Newdos + 3.0		\$99.95
Slalom		\$7.95
Air Raid		\$14.95
All Star Baseball		\$7.95
Batter Up		\$5.95
X-Wing Fighter II		\$9.95
Ten Pin		\$7.95
Taipan		\$9.95
Balloon Race		\$9.95
Adventures: By Scott Adams		
Land Adventure	Pirate's Cove	
Mission Impossible	Voodoo Castle	
The Count		
Any two on Disk, 32K		\$24.95
Any three on Disk, 32K		\$39.95
On tape, Level II, 16K		\$14.95

WANTED USED TRS-80 EQUIPMENT! We Buy And Sell Used Equipment

Sample Prices

UNIT	BUY	SELL
4K Level I	275	375
16K Level II	500	650
0K Interface	175	240
#1160 Disk Drive	300	399

CALL OR WRITE FOR DETAILS!

NEW! ALL TRS-80 EQUIPMENT, 10% OFF!
Factory sealed, with a Radio Shack sales slip and warranty! 16K Level II - \$764.00, 16K Interface - \$403.00 (plus shipping).

Call Or Write For A Complete Price List.

"NOW AN AUTHORIZED EXIDY DEALER"

Step up the the amazing Exidy Sorcerer. Features high-resolution graphics, 64 x 30 character video, monitor and fast floating point BASIC in ROM, user-definable character set, and the best keyboard of any micro. Sorcerer power can be yours for \$995 (8K RAM), \$1145 (16K), and \$150 per 16K additional. A wide range of system and application software is also available.

<input type="checkbox"/> Journey To The Center Of The Earth	\$7.95
<input type="checkbox"/> Dog Star Adventure	\$9.95
<input type="checkbox"/> Amazin' Mazes	\$7.95

Kamikaze		\$7.95
Space Battles	Tape-\$14.95; Disk -	\$19.95
Electronics Assistant		\$9.95
3-D Tic Tac Toe		\$7.95
Star Trek III.3		\$14.95
End Zone		\$7.95
Cribbage		\$7.95
'Round The Horn		\$9.95

Ham Radio		
Special Disk-enhanced version, 32K		\$24.95
Tape -		\$9.95

Educator Assistant		\$14.95
Typing Tutor		\$19.95
Personal Finance		\$9.95
Advanced Personal Finance	Disk	\$24.95
KVP Extender Tape - \$24.95; Disk		\$29.95
Level III Basic		\$49.95

MMSFORTH		
Cassette version, Level II, 16K		\$39.95
Disk version, Level II, 16K		\$49.95
MicroForth primer		\$15.00

TRS-80 Fortran		\$99.00
TRS-80 Macro Assembler	Disk	\$99.00
Concentration		\$7.95
Safari		\$7.95
Pork Barrel		\$9.95
Backgammon		\$7.95
Chess Companion		\$7.95
Sargon Chess		\$19.95
Mastermind II.2		\$7.95
RPN Calculator		\$9.95
Home Financial Management		\$9.95
Secrets Of The Tarot		\$9.95

SoftSide™

SoftSide is for pioneers . . . those hardy souls who have adopted a TRS-80, installed it in their living-room or office, and unleashed their imaginations.

SoftSide helps you discover the endless variety of tasks your new friend will do for you, as you build a unique partnership of human being and machine.

We publish software for the partners. Every month we publish games, household application programs, educational aids, business programs. We help you realize your expectations, fantasies, and dreams.

SoftSide means Software!

PROG/80

A bi-monthly magazine for the serious programmer who wants to know HOW his computer works and WHY. PROG/80 emphasizes technique rather than canned programs. The subjects include machine language, construction projects and specialized applications software, not just for the advanced computer hobbyist, but for the computerphile who wants the most from his machine.

Apple Seed

If you're an Apple II pioneer, you've been longing for a software publication and hoping someone would get around to it.

We have. Apple Seed is to the Apple II what SoftSide is to the TRS-80. And it's brand new. The first issue will roll off the press in August or September. Apple II enthusiasts will eat up this special introductory offer!

TSE TRS-80 Software Exchange

Our New Watts Line # is
1-800-258-1790

DEALER INQUIRIES INVITED
For more information, please call our
Customer Service Department at:

1-603-673-5144

17 Briar Cliff Drive

Milford, NH 03055

SOFTSIDE

1 Year - 12 issues \$18.00

PROG/80

1 Year - 6 issues \$15.00

APPLE SEED

1 Year - 12 issues \$15.00

PO Box 68 Milford, NH 03055

- USA first class \$25.00 - 1 yr.
- APO/OVERSEAS surface \$25 - 1 yr.
- CANADA/MEXICO \$25 - 1 yr.
- OVERSEAS airmail \$30 - 1 yr.

Exp. Date _____ Interbank # [M/C only] _____

Signature _____

Name _____

Address _____

City _____ State _____ Zip _____

Telephone orders accepted for Master Charge or VISA accounts. Call Monday through
Friday, 9:30 to 5:30 EST at 603-673-5144

VOTRAX	ASCII	DECIMAL	VOTRAX	ASCII	DECIMAL
PA1 *		32	A1	@	64
I2	!	33	AH2	A	65
I	"	34	B	B	66
I3	#	35	CH	C	67
OO	\$	36	D	D	68
OO1	%	37	E1	E	69
Y	&	38	F	F	70
U	'	39	G	G	71
IU	<	40	H	H	72
A2	>	41	I1	I	73
AY	*	42	J	J	74
NG	+	43	K	K	75
AW	,	44	L	L	76
Ø DEC.	-	45	M	M	77
E	.	46	N	N	78
ER	/	47	O1	O	79
PAØ *	Ø	48	P	P	80
AW1	1	49	DT	Q	81
AW2	2	50	R	R	82
EH1	3	51	S	S	83
EH2	4	52	T	T	84
EH3	5	53	U1	U	85
UH1	6	54	V	V	86
UH2	7	55	W	W	87
UH3	8	56	ZH	X	88
AE1	9	57	Y1	Y	89
AE	:	58	Z	Z	90
AH1	;	59	O2	[91
THV	<	60	O	\	92
TH	=	61	AH]	93
SH	>	62	A	^	94
WINDOW	?	63	NULL	_	95

Table 1: Relationship between Votrax phoneme symbols and ASCII characters used by the TRS-80. The decimal value of the ASCII character is also shown. The ASCII character is placed in the output window, and the synthesizer produces the corresponding sound. The synthesizer must use special phoneme characters to represent its sounds because standard alphabet characters often have several different pronunciations assigned to them.

words and phrases from the constituent sounds of a particular human language. These constituent sounds are called phonemes. The machine need produce only a subset of possible human sounds to be intelligible. Comparison of the phoneme subsets of various languages shows that there is a large intersection of phonemes between them. This means that given the phoneme subset of a particular language, several other languages can be produced from the same subset with a high degree of accuracy.

The TRS-80 voice synthesizer is an English language phoneme synthesizer. Table 1 lists all of the phonemes produced by the Votrax phoneme symbols, with the associated ASCII character and decimal code. The ASCII character, hereafter referred to as the *phoneme character*, is used in BASIC statements to select phonemes. The Votrax phoneme symbol is a

mnemonic descriptor, for it spells the sound associated with that phoneme.

There are 62 phonemes from which to select. Several vowel phonemes have multiple listings, such as UH1, UH2, UH3. These are different durations of the "uh" sound. The larger the digit, the shorter the duration of the sound. The range of phoneme duration is 50 to 200 ms. The long duration version of a vowel phoneme (eg: EH1) is used in a word with only 1 vowel, or in the syllable of a word that is accented or stressed (eg: yes, better). Shorter duration versions of the vowel (eg: EH2, EH3) are used in unstressed syllables (eg: seven).

The phonemes listed in table 1 have been broken down into general groupings which are shown in table 2. In a physical sense, *voiced* phonemes can be thought of as those having pitch and amplitude resulting from vocal cord vibrations (such as are produced by humming). *Unvoiced*



By Netronics

ASCII/BAUDOT,
STAND ALONE

Computer Terminal
COMPLETE FOR ONLY \$149⁹⁵

The Netronics ASCII/BAUDOT Computer Terminal Kit is a microprocessor-controlled, stand alone keyboard/terminal requiring no computer memory or software. It allows the use of either a 64 or 32 character by 16 line professional display format with selectable baud rate, RS232-C or 20 ma. output, full cursor control and 75 ohm composite video output.

The keyboard follows the standard typewriter configuration and generates the entire 128 character ASCII upper/lower case set with 96 printable characters. Features include onboard regulators, selectable parity, shift lock key, alpha lock jumper, a drive capability of one TTY load, and the ability to mate directly with almost any computer, including the new Explorer/85 and ELF products by Netronics.

The Computer Terminal requires no I/O mapping and includes 1k of memory, character generator, 2 key rollover, processor controlled cursor control, parallel ASCII/BAUDOT to serial conversion and serial to video processing—fully crystal controlled for superb accuracy. PC boards are the highest quality glass epoxy for the ultimate in reliability and long life.

VIDEO DISPLAY SPECIFICATIONS

The heart of the Netronics Computer Terminal is the microprocessor-controlled Netronics Video Display Board (VID) which allows the terminal to utilize either a parallel ASCII or BAUDOT signal source. The VID converts the parallel data to serial data which is then formatted to either RS232-C or 20 ma. current loop output, which can be connected to the serial I/O on your computer or other interface, i.e., Modem.

When connected to a computer, the computer must echo the character received. This data is received by the VID which processes the information, converting to data to video suitable to be displayed on a TV set (using an RF modulator) or on a video monitor. The VID generates the cursor, horizontal and vertical sync pulses and performs the housekeeping relative to which character and where it is to be displayed on the screen.

Video Output: 1.5 P/P into 75 ohm (EIA RS-170) • Baud Rate: 110 and 300 ASCII • Outputs: RS232-C or 20 ma. current loop • ASCII Character Set: 128 printable characters—



BAUDOT Character Set: A B C D E F G H I J K L M N O P Q R S T U V W X Y Z - ? : * 3 \$ # () . , 9 0 1 4 5 7 ; 2 / 6 8 •
Cursor Modes: Home, Backspace, Horizontal Tab, Line Feed, Vertical Tab, Carriage Return. Two special cursor sequences are provided for absolute and relative X-Y cursor addressing •
Cursor Control: Erase, End of Line, Erase of Screen, Form Feed, Delete • Monitor Operation: 50 or 60Hz (jumper selectable).

Continental U.S.A. Credit Card Buyers Outside Connecticut
CALL TOLL FREE 800-243-7428

To Order From Connecticut Or For Technical Assistance, Etc. Call (203) 354-9375

Netronics R&D Ltd., Dept. PE-9
333 Litchfield Road, New Milford, CT 06776

Please send the items checked below—

- Netronics Stand Alone ASCII Keyboard/Computer Terminal Kit, \$149.95 plus \$3.00 postage & handling.
- Deluxe Steel Cabinet for Netronics Keyboard/Terminal In Blue/Black Finish, \$19.95 plus \$2.50 postage and handling.
- Video Display Board Kit alone (less keyboard), \$89.95 plus \$3 postage & handling.
- 12" Video Monitor (10 MHz bandwidth) fully assembled and tested, \$139.95 plus \$5 postage and handling.
- RF Modulator Kit (to use your TV set for a monitor), \$8.95 postpaid.
- 5 amp Power Supply Kit In Deluxe Steel Cabinet (±8VDC @ 5 amps, plus 6-8 VAC), \$39.95 plus \$2 postage & handling.

Total Enclosed (Conn. res. add sales tax) \$ _____
By _____

Personal Check Cashiers Check/Money Order
 Visa Master Charge (Bank # _____)

Acct. # _____
Signature _____ Exp. Date _____
Print Name _____
Address _____
City _____
State _____ Zip _____

Send Me More Information

(or voiceless) phonemes are those without vocal cord vibrations, where pitch might not be detected. These phonemes are perceived as hissing.

All phonemes except the stop plosives produce their sound shortly after being selected. Vocal parameters at phoneme boundaries do not change abruptly, but smoothly from one set of values to the next. The exception to this is the stop plosives, which do not make any sound until the phoneme following it begins. When a stop plosive is selected, vocal parameters are adjusted for silence until the beginning of the next phoneme. At this time, the stop plosive phoneme explodes into the following phoneme. An example of this is the word *kick*. The phoneme sequence for this word is PA1, K, I2, K, PA1. The timing of these sounds is graphically depicted in figure 1.

Phoneme symbols, with typical examples of English words in which they might be used, are provided in table 3. The English letter combination that the phoneme replaces has been underlined. In addition, table 4 shows phoneme sequences to produce

	Voiced	Unvoiced	Group Name
Consonants	B, D, G	T, P, K, DT	Stop Plosives
	Z, ZH, V, THV, J*	S, SH, F, TH, H, CH*	Fricatives
	M, N, NG		Nasals
Vowels	R, L, W, Y, ER		Semivowels
	A*, E, I, O, U	AW, EH, UH, AH,	
	AE, OO, IU*, AY*, Y1*		

Table 2: *Votrax phoneme groupings. The allophones (phoneme variations) marked with asterisks are phoneme variations which must be combined with another phoneme to complete the production of an English sound unit.*

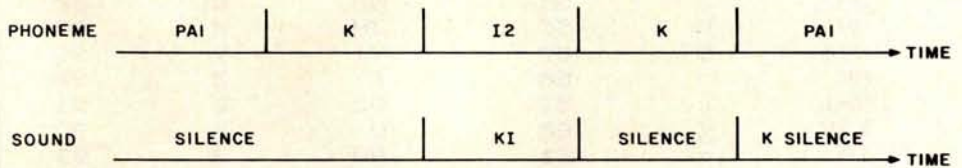

Figure 1: *Progression of stop plosive sequence. The top line shows the phonemes selected during a given instant, and the bottom line shows the sound produced during that instant.*

Omikron transforms TRS-80* into a powerful business system.

STANDARD DRIVES 8" Drives give you 5 times the speed and 3 times the storage of your mini drives! Our system provides a standard Shugart interface so you can use either your 8" drives or ours. Omikron drives are enclosed in an attractive metal cabinet, and include a power supply.

SOFTWARE CP/M* is the most popular operating system for microcomputers. But many high-level languages and advanced business programs cannot run with the special CP/M* designed exclusively for the TRS-80*. The Omikron MAPPER with standard CP/M* allows you to expand your software capability to go beyond the few available TRS-80* compatible packages.

TRS-80* with MAPPER out-performs systems costing \$1000 more!

The MAPPER I and MAPPER II are plug-in modules. They don't require any circuit changes, are easy to install, and they don't interfere with the normal operation of your TRS-80*. All your original software, including Level III BASIC will still run properly. Omikron products require 16K L II BASIC and the TRS-80* Expansion Interface.

★ ★ ★

MAPPER I is a memory management unit which adapts your TRS-80* to run standard CP/M*. Versions for both 5" and 8" drives are available. The package includes CP/M* software on 5" or 8" diskette, and documentation. 5" unit, \$169. 8" unit, with adapter cable, \$199.

MAPPER II includes the MAPPER I package plus a disk adapter module which allows both 5" and 8" drives to run on the same cable. Drive selection is under software control to permit easy file transfer between the drives. With cable, \$249.

CONVERSION —If you purchase MAPPER I or II and plan to use only mini-drives, Omikron will transfer CP/M* files from 8" diskette to a 5". This allows you to run software previously available to only 8" drive owners. \$25 per mini-diskette.

DRIVE — 8" drive, \$849. Additional drive, \$695. **WARRANTY** — 1 year on boards; 90 days on drives. VISA/MasterCharge accepted. Prepaid orders given top priority.

*CP/M is a TM of Digital Research. TRS-80 is a TM of Tandy Corporation.



ComputerLand®

Introducing the Personal Computing Shopping Centers



Off-The-Shelf Software

In the past few years, many fine personal computers have been available, but not much software to use with them. ComputerLand has now taken the lead to make personal computing software available to everyone with Soft Spot™, an exclusive, custom-designed, self-merchandising fixture. You can select off-the-shelf programs for personal use in finance, time-budgeting, education, sophisticated games, stock portfolio evaluation and much, much more.

Soft Spot™ will assist you in quickly selecting the educational, recreational, and practical software you want, starting at \$7.95 from major suppliers like Apple Computer, Inc., Personal Software, Program Design, Inc., Commodore, Powersoft, Softape, and others. Stop in today at ComputerLand's Soft Spot™, and choose from a wide variety of the finest software available.

A Storehouse of Knowledge

Main Brain™ is your one-stop center for books, self-study courses and other educational media on personal computing. Self-study cassettes, video tape courses, "in-person" lecture programs and more is available to you from well-known publishers such as Sybex, Osborne and Associates, and Hayden.

Main Brain™ has self-service instructions to assist you in choosing from a variety of desired multi-media products from "introductory" through "hands-on" to "in-depth" levels. It's all available to you at ComputerLand's Main Brain™, your one-stop center for educational media on personal computing.



Available at all participating ComputerLand stores

Huntsville, AL
Phoenix, AZ
Little Rock, AR
Belmont, CA
Dublin, CA
El Cerrito, CA
Hayward, CA
Lawndale, CA
Los Altos, CA
Los Angeles, CA
Pasadena, CA
Sacramento, CA
Saddleback Valley, CA
San Bernardino, CA
San Diego, CA
San Diego East, CA
San Francisco, CA

San Jose, CA
San Rafael, CA
Santa Maria, CA
Santa Rosa, CA
Thousand Oaks, CA
Tustin, CA
Walnut Creek, CA
Colorado Springs, CO
Denver, CO
North Denver, CO
Fairfield, CT
Hartford, CT
Newark, DE
Boca Raton, FL
Ft. Lauderdale, FL
Jacksonville, FL
Miami, FL

Tampa, FL
Atlanta, GA
Honolulu, HI
Arlington Heights, IL
Downers Grove, IL
Mundelein, IL
Niles, IL
Oak Lawn, IL
Peoria, IL
Indianapolis, IN
Overland Park, KS
Louisville, KY
Boston, MA
Rockville, MD
Grand Rapids, MI
Rochester, MI
Southfield, MI

Bloomington, MN
Hopkins, MN
Independence, MO
Springfield, MO
St. Louis, MO
Omaha, NE
Nashua, NH
Cherry Hill, NJ
Bergen County, NJ
Morristown, NJ
Buffalo, NY
Ithaca, NY
Nassau County, NY
Charlotte, NC
Cleveland East, OH
Cleveland West, OH
Columbus, OH
Oklahoma City, OK

Portland, OR
Harrisburg, PA
Lehigh Valley, PA
Paoli, PA
Austin, TX
Dallas, TX
South West Houston, TX
Houston Bay Area, TX
Salt Lake City, UT
Tyson's Corners, VA
Bellevue, WA

Federal Way, WA
Tacoma, WA
Madison, WI
Milwaukee, WI
INTERNATIONAL
Adelaide, Australia
Brisbane, Australia
Melbourne, Australia
Perth, Australia
Sydney, Australia
Brussels, Belgium

Burlington, Canada
Calgary, Canada
Toronto, Canada
Winnipeg, Canada
Copenhagen, Denmark
Paris, France
Manila, Philippines
Singapore
Stockholm, Sweden
and other
locations worldwide.

Product availability may vary by regional location

ComputerLand®

WE KNOW SMALL COMPUTERS

14400 Catalina St., San Leandro, CA (415) 895-9363

multisound units, referred to as diphthongs. Again, the letters in the example word showing where the diphthong goes have been underlined. To give examples of phonetic programming, some commonly used computer words have been listed in table 5.

Basic Operation

Output to the voice synthesizer is accomplished by executing a PRINT AT statement (or PRINT@ for Level II), coupled with the device select/deselect character. Referring to figure 2, an imaginary box enclosing the last 32 positions of the video display is shown. This box defines a window through which printed characters are sent to the voice synthesizer. The sending of a character to the synthesizer happens when the window is open. If the window is closed, any character printed within cannot affect the synthesizer. Opening and closing the window is controlled by printing a "?" within the window. The "?"

printed inside the window is considered a device select/deselect character.

As phoneme characters are printed into the open window, they are also shifted into a 32-stage first-in first-out (FIFO) buffer. This buffer is in the synthesizer interface and is address mapped into the last 32 locations of the video-display refresh memory. Phoneme characters in this buffer determine which sounds the synthesizer produces. Each phoneme duration is timed by the synthesizer. The next phoneme character is removed from the buffer at the end of each cycle. This continues until the buffer is emptied. The synthesizer will continue to process the last character entered in the buffer. This last character should be a pause (or silent) phoneme. This will prevent any sound phoneme from being produced while the synthesizer is in an unused state.

It is a good practice to set up the synthesizer output command in a

subroutine. This subroutine should contain the following sequence of operations:

- Open the window (print a "?" in the window).
- Print a " " (use space bar) in the window to synchronize the synthesizer when it has been in an idle state (" " is a pause phoneme).
- Print phoneme characters in the window in the sequence they will be voiced.

Text continued on page 122

Votrax Phonetic Symbol	Key Word
B	<u>bat</u> - <u>rub</u>
D	<u>dad</u> - <u>raid</u>
G	<u>get</u> - <u>log</u>
T	<u>tip</u> - <u>pat</u> - <u>asked</u>
P	<u>pack</u> - <u>flap</u> - <u>happy</u>
K	<u>kill</u> - <u>kick</u>
DT	<u>butter</u>
Z	<u>zap</u> - <u>haze</u> - <u>pans</u>
ZH	<u>pleasure</u> - <u>azure</u>
V	<u>van</u> - <u>pave</u>
THV	<u>the</u> - <u>smooth</u> - <u>mother</u>
J*	<u>job</u> - <u>jazz</u>
S	<u>soup</u> - <u>ask</u> - <u>pass</u> - <u>city</u>
SH	<u>sheep</u> - <u>fish</u> - <u>action</u>
F	<u>fake</u> - <u>cuff</u> - <u>phone</u>
TH	<u>thing</u> - <u>math</u>
H	<u>hoop</u> - <u>have</u>
CH*	<u>cheese</u> - <u>march</u> - <u>match</u>
M	<u>mat</u> - <u>dim</u>
N	<u>no</u> - <u>son</u>
NG	<u>ring</u> - <u>drink</u> - <u>shingle</u>
R	<u>race</u> - <u>hard</u> - <u>hair</u>
L	<u>low</u> - <u>late</u>
W	<u>wake</u> - <u>always</u> - <u>when</u>
Y	<u>yard</u> - <u>berry</u>
A*	<u>tame</u> - <u>pail</u> - <u>make</u>
E	<u>beef</u> - <u>be</u> - <u>even</u>
I	<u>pit</u> - <u>in</u>
O	<u>for</u> - <u>torn</u> - <u>bold</u>
U	<u>move</u> - <u>school</u> - <u>June</u>
AE	<u>dad</u> - <u>plaid</u>
AW	<u>call</u> - <u>paw</u>
EH	<u>ready</u> - <u>leg</u>
ER	<u>third</u> - <u>heard</u> - <u>churn</u> - <u>over</u>
UH	<u>around</u> - <u>undone</u> - <u>friction</u>
OO	<u>took</u> - <u>put</u> - <u>good</u>
IU*	<u>you</u> - <u>music</u>
AY*	<u>jade</u> - <u>made</u> - <u>claim</u>
Y1*	<u>you</u> - <u>music</u>

Table 3: List of Votrax phoneme symbols with examples of the occurrence of the corresponding sound in English words. The English letter combination the phoneme replaces is indicated. The allophones (see table 2) are marked with asterisks.

NEW POWER FOR YOUR APPLE. FROM MOUNTAIN HARDWARE.

ROMPLUS+

Software in firmware.
ROMPLUS+ allows you to add up to 6 individually addressable ROM's or EPROM's to your Apple.*

New Power. Keyboard Filter,** a programmed 2K ROM adds over a dozen useful features to your Apple:

- Upper/lower case letters plus printer output • Keyboard macros. Including BASIC and DOS commands.
- Improved cursor control for editing.
- Multiple user-defined character sets.
- Colored or inverse colored letters.
- Page switching. • Stop list and End list.
- Copy one entire line at a time... and much more.

Features: On board scratch-pad RAM. On-board control ROM handles programs longer than 2K, plus ROM select and memory allocations. Two TTL inputs for control or U/L "shift-key" operation. \$169 complete and tested. Including Keyboard Filter and full documentation.

At your dealer. Now.

Mountain Hardware, Inc.

LEADERSHIP IN COMPUTER PERIPHERALS
300 Harvey West Blvd., Santa Cruz, CA 95060 (408) 429-8600

*Apple is a trademark of Apple Computer Inc.

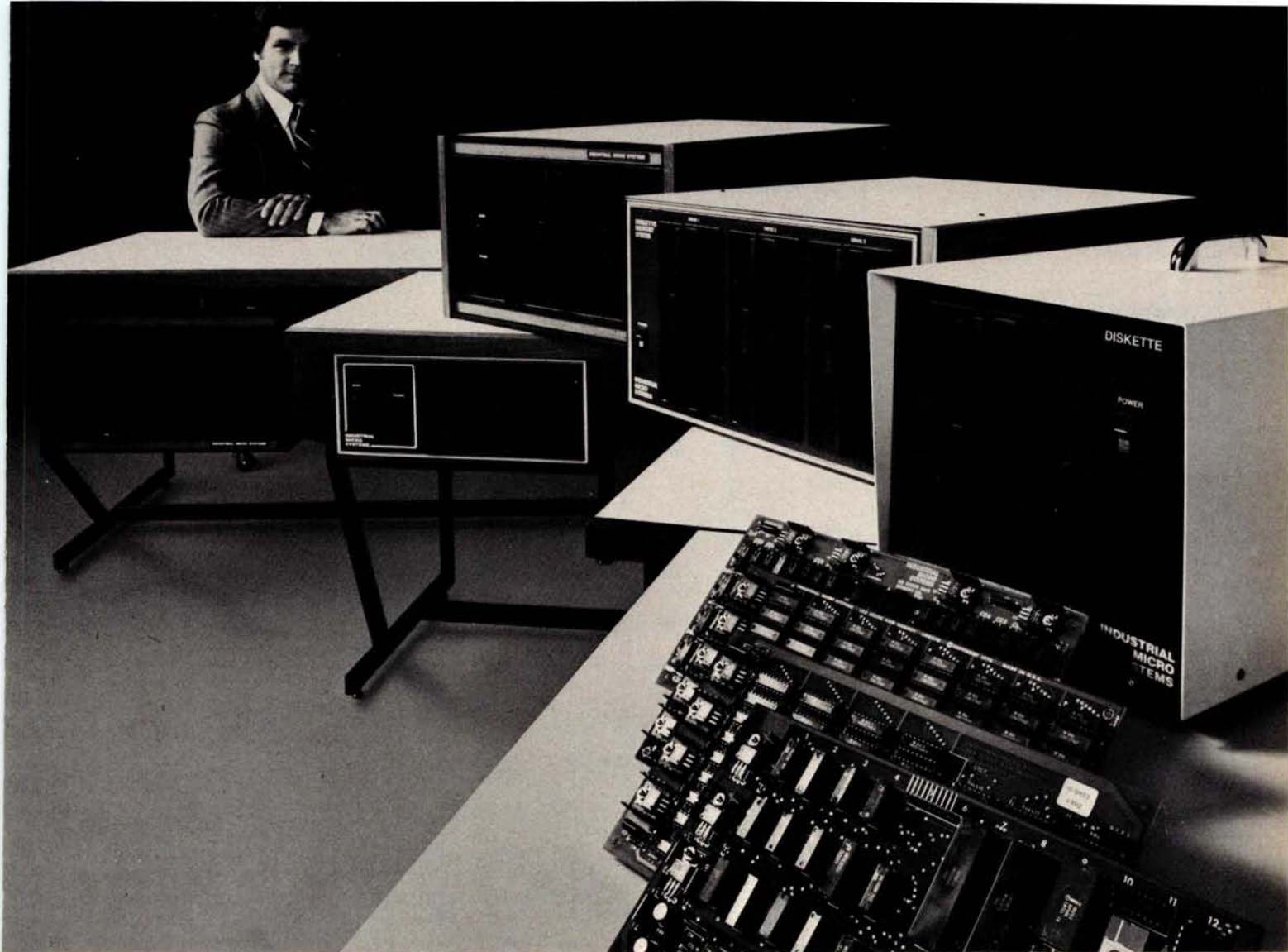

The line your reputation should be on.

When a computer supplier or retailer sells equipment, his reputation is on the line.

And when the customer has to justify his investment decision, his reputation is on the line too.

So, naturally, everybody's a lot better off on a reliable line. Like ours.

With a name like Industrial Micro Systems, we wouldn't think of building anything short of industrial standards... even our S-100 products.

No short cuts or jumpers.

All of our boards — CPU, memory and controllers — are made from real fiberglass instead of a plastic substitute. And contacts are gold plated over a copper-ion barrier of nickel.

Every disk enclosure features a heavy-gauge steel chassis, and a heavy duty power supply. Built to take it.

Then come our complete systems. Aside from the disk drives, we manufacture every component that goes into them. Even the desk that goes around them. So

we can vouch for rugged reliability inside and out.

Two complete systems:

Our new Series 5000 features a megabyte of storage on integral mini-floppies. And our Series 8000 is all business too. It can handle up to three megabytes on 8-inch drives. A large library of software, growing daily, includes CP/M,* PASCAL, and FAMOS.**

Breaking the 64k barrier.

Using Industrial Micro Systems 32k memory boards with Memory Management, our systems can handle up to 576k RAM internally.

More in store.

That's not the end of the line. It's growing all the time, along with our reputation for quality. Put your reputation on the line. Our line.

For more details just call or write. Supplier/dealer inquiries welcomed.

Industrial Micro Systems, 628 N. Eckhoff, Orange, CA 92668. (714) 633-0355.

INDUSTRIAL MICRO SYSTEMS

The great unknown.

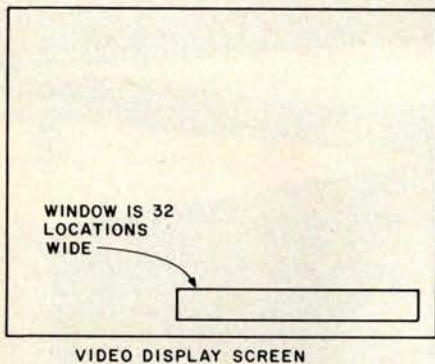

Figure 2: Location of the synthesizer output window on the video display screen. The voice synthesizer continually scans the area of memory corresponding to that region of the screen. When the vocal output is selected (by printing a question mark in the window), any character printed in the window is interpreted as a phoneme representation and is spoken.

Symbol Combination	Key Words
A1, AY	<u>t</u> ame
Y1, IU, U1	<u>y</u> ou - <u>u</u> nit
AH1, I2, E1	<u>c</u> limb - <u>c</u> rime
UH1, AH2, E1	<u>w</u> hite - <u>n</u> ight
O1, U1	<u>b</u> oat - <u>s</u> how
AH1, U1	<u>c</u> ow - <u>s</u> ound
AH2, UH1, U1	<u>m</u> ouse - <u>a</u> bout
O1, UH1, E1	<u>t</u> oy - <u>p</u> oint
A2, EH1	<u>f</u> are - <u>p</u> ear
E1, I1	<u>h</u> ere - <u>b</u> eer

Table 4: Phoneme sequences to produce diphthongs, wherein 2 vowel sounds occur adjacently, with no intervening consonant. The English letters replaced by the phoneme sequence are indicated.

Table 5: Votrax phoneme and ASCII representations of common words in computer applications. The ASCII coding may be entered directly into programs for vocal output.

BUFFER	B	UH3	UH2	F	ER					(VOTRAX)		
	B	8	7	F						(ASCII)		
FULL	F	OO1	OO1	L						(VOTRAX)		
	F	%	%	L						(ASCII)		
RUN	R	UH3	UH1	N	N					(VOTRAX)		
	R	8	6	N	N					(ASCII)		
STOP	S	T	AH1	UH3	P					(VOTRAX)		
	S	T	:	8	P					(ASCII)		
READY	R	EH1	EH3	D	Y					(VOTRAX)		
	R	3	5	D	&					(ASCII)		
SAVE	S	S	A1	AY	Y	V				(VOTRAX)		
	S	S	@	*	&	V				(ASCII)		
HELLO	H	EH1	UH3	L	UH3	O2	U1			(VOTRAX)		
	H	3	8	L	8		U			(ASCII)		
TALK	T	AW2	L	K						(VOTRAX)		
	T	2	L	K						(ASCII)		
YES	Y1	EH2	EH1	S	S					(VOTRAX)		
	Y	4	3	S	S					(ASCII)		
NO	N	UH3	O1	O1	U1					(VOTRAX)		
	N	8	O	O	U					(ASCII)		
CANCEL	K	AE1	EH3	N	S	UH3	L			(VOTRAX)		
	K	9	5	N	S	8	L			(ASCII)		
ADD	AE1	AE1	EH3	D						(VOTRAX)		
	9	9	5	D						(ASCII)		
SUBTRACT	S	UH2	B	PA0	T	R	AE1	AE1	K	PA0	T	(VOTRAX)
	S	7	B	0	T	R	9	9	K	0	T	(ASCII)
MULTIPLY	M	UH2	L	T	UH3	P	L	AH1	Y			(VOTRAX)
	M	7	L	T	8	P	L	:	&			(ASCII)
DIVIDE	D	I2	V	AH2	AH1	EH3	I3	AY	D			(VOTRAX)
	D	!	V	A	:5	#	* D					(ASCII)
EQUALS	E1	AY	K	W	OO1	L	Z					(VOTRAX)
	E	*	K	W	%	L	Z					(ASCII)
ENTER	EH1	N	T	ER								(VOTRAX)
	3	N	T	/								(ASCII)
ZERO	Z	AY	I3	R	UH3	O2	U1					(VOTRAX)
	Z	*	#	R	8		U					(ASCII)
ONE	W	UH3	UH2	UH2	N	N						(VOTRAX)
	W	8	7	7	N	N						(ASCII)
TWO	T	IU	IU	U1	U1							(VOTRAX)
	T	((U	U							(ASCII)

Table 5 continued on page 122

A Challenge to Software Authors

The MicroNET division of CompuServe* is offering an innovative, new concept of program marketing and distribution for personal computer software. Because of this we are continually looking to expand our already extensive library of personal computer programs. This is a unique opportunity for authors of the highest quality programs only. We will consider highly human-engineered software with a wide range of appeal to users, such as:

- Educational Programs
- Personal and Home Applications
- Unique Small Business Programs
- Data Bases
- Entertainment
- Hobby Applications

If you think your program qualifies, send a brief description of the program — including its operating environment, special features and benefits to the user. If your program appears to meet our standards, we will contact you with details of our licensing agreements.

Are you good enough to qualify?

Personal Computing Division of CompuServe
5000 Arlington Centre Blvd.
Columbus, Ohio 43220

MicroNET

* See ad on page 51



We want you to
always have
a perfect
record.

Ours.

Maxell has the best quality control record in the industry. So we're certain to always give you the best Floppy Disks in the world.

Some reasons why Maxell is so good.

Every Maxell Floppy Disk is guaranteed to be perfect. We tolerate no ifs, ands, buts, excuses, or dropouts. It's that simple . . . and that tough.

In fact we have developed innovative manufacturing techniques that actually slow down certain processes, sacrificing speed to gain quality. And our unique binder system, developed by our own engineers, applies the magnetic oxide with amazing uniformity and surface smoothness.

Ten out of ten: a perfect record.

Of course, Maxell Floppy Disks conform to ISO and IBM specifications. They also have been recommended by major OEMs, because Maxell works best with their hardware.

Circle 212 on inquiry card.

So open a box, and know in advance that it holds ten perfect floppys. You're right to not settle for anything less. Neither do we.

Maxell offers the full range of Floppy Disks, from standard 8-inch to 5 1/4-inch, plus Data Cassettes. *Dealer inquiries invited.*



Maxell Corporation of America, Data Products Group
60 Oxford Drive, Moonachie, NJ 07074 Tel. (201) 440-8020

Table 5 continued from page 120:

THREE	TH =	TH =	R R	E .	Y &	(VOTRAX) (ASCII)				
FOUR	F F	O1 O	O1 O	R R		(VOTRAX) (ASCII)				
FIVE	F F	AH2 A	AH1 ;	I3 #	Y &	V V	V V	(VOTRAX) (ASCII)		
SIX	S S	I1 I	I3 #	K K	PA0 0	S S		(VOTRAX) (ASCII)		
SEVEN	S S	EH3 5	EH2 4	V V	EH2 4	N N	N N	(VOTRAX) (ASCII)		
EIGHT	A2)	A2)	AY .	Y &	T T			(VOTRAX) (ASCII)		
NINE	N N	AH1 ;	EH2 4	Y &	N N			(VOTRAX) (ASCII)		
TRS-80	T T	E1 E	E1 E	AH1 ;	UH3 8	R R	EH1 3	S S	S S	PA0 0 (VOTRAX) (ASCII)
	A1 ¼	AY .	Y &	D D	Y1 Y	(VOTRAX) (ASCII)				
VOICE	V V	01 0	UH3 8	EH3 5	Y Y	S S	S S	(VOTRAX) (ASCII)		
SYNTHESIZER	S S	I1 I	N N	TH =	UH3 8	S S	AH1 ;	Y &	Z Z	ER / (VOTRAX) (ASCII)
COMPUTER	K K	UH1 6	M M	P P	Y1 Y	IU (U1 U	T T	ER /	(VOTRAX) (ASCII)
SPEECH	S S	P P	E1 E	Y &	T T	CH C				(VOTRAX) (ASCII)
PHONEMES	F F	02 I	02 I	N N	AY .	Y &	M M	Z Z		(VOTRAX) (ASCII)
OPERATOR	AH1 ;	P P	ER /	A1 ¼	AY .	T T	ER /			(VOTRAX) (ASCII)

```

1000 PRINT AT 992,"? ";A$;" ?";
1010 PRINT AT 992," "
1020 RETURN

1000 PRINT@ 992,"? ";A$;" ?";
1010 PRINT@ 992," "
1020 RETURN

```

Listing 1: Subroutines for synthesizer output in Radio Shack Level I (listing 1) and Level II (listing 1b) BASIC. Line 1000 opens the output window in the video display, sends a pause, sends the phoneme characters stored in A\$, sends another pause, and closes the window. Line 1010 fills the window with 31 spaces to blank out the display. Line 1020 returns to the calling routine.

```

1000 POKE 16383,63 : POKE 16383,32
1010 FOR Y = 1 TO LEN (A$)
1020 POKE 16383, ASC(MID$(A$,Y,1))
1030 NEXT Y
1040 POKE 16383,32 : POKE 16383,63 : POKE 16383,32
1050 RETURN

```

Listing 2: Modified subroutine for synthesizer output for Level II BASIC only. Phoneme characters are taken out of A\$ one at a time, and are POKEd into decimal location 16383, the last location in the output window. This method of output does not disturb the cursor position, thereby saving overhead of restoring the cursor.

Text continued from page 118:

- Repeat last step if multiple messages are desired.
- Print a " " in the window (a pause for silence at the end of the message).
- Close the window (print a "?" in the window).
- Print spaces in the window to blank out the characters in the video display that were sent to the synthesizer.

An example of this sequence is shown in listing 1. A variation on this subroutine which Level II users might consider is shown in listing 2.

The phoneme character strings which form words when sent to the synthesizer may be stored in several ways. The simplest way is to store the phoneme strings in a BASIC string variable and then call the voice driver subroutine. An example is A\$="TUD@Y": GOSUB 1000. This transmits the phoneme characters for the word "today." DATA statements may be used to create a lookup table where the English spelling of a word is stored adjacent to the phoneme character string for that word. This would be useful, for example, in creating a name storage table for a game. A user could enter his or her name from the keyboard, and the computer could search the table for a name match and the associated phoneme characters needed to pronounce the name. It is a funny sensation to be verbally addressed, by name, by a computer.

Summary

Merely reading about how to string phonemes together on a TRS-80 voice synthesizer cannot begin to convey the excitement your friends will experience when your computer talks to them. Applications of a voice response system are exciting and plentiful. Any TRS-80 computer can add this voice synthesizer unit without any hardware modification. Changing existing application software to include voice response requires inserting only a few lines of code. Applications of computers in the home will surely come to rely on voice response as one of the most important output devices. ■

Solve Problems By Simulation...

with simulations of many concepts, including

- wave motion
- flying objects
- artificial intelligence
- electronic circuits
- and robot motion!

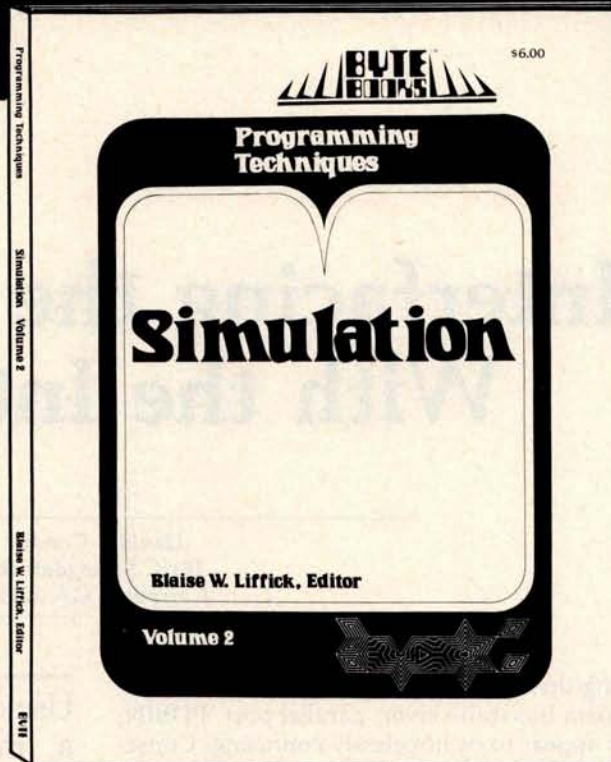

SIMULATION is a collection of the best articles from **BYTE Magazine** on this useful computer technique, plus exciting new material on the subject.

SIMULATION is the second volume in the **Programming Techniques** series on the art and science of computer programming from **BYTE BOOKS**. Editor **Blaise W. Liffick's** selection of material furnishes not only background information from which the personal computer user is able to write and maintain simulation programs, but also actual programs for simulating many situations. Theoretical and practical applications of this technique are explored in articles dealing with specific aspects of simulation.

Learn how to find solutions to your problems through **SIMULATION**.

\$6.00

ISBN 0-931718-13-9

Buy this book at your favorite computer bookstore or order direct from **BYTE BOOKS**.
Add 60¢ per book for postage and handling



"BOOKS OF INTEREST TO COMPUTER PEOPLE"

70 Main Street, Peterborough, New Hampshire 03458

Interfacing the S-100 Bus With the Intel 8255

David L Condra
161-C Springdale Rd
Carrollton GA 30117

Upon entering the world of microcomputers, technical terms such as data bus transceiver, parallel port, PDBIN, and strobe can appear to be hopelessly confusing. Consequently, many people avoid hardware and concentrate their efforts on software, feeling that it is easier to understand. However, as with software, if a hardware project is broken down into manageable modules, it can be easily designed and understood. This is particularly true with the new large-scale integration devices that are available today. Use of these parts almost forces a modular approach to a design problem.

When faced with the job of designing an interface for a Diablo printer, I began looking at the available interface parts. I was amazed at how simple these devices can make an interface design project. In this article I will discuss the Intel 8255 programmable peripheral interface, and its use for interfacing to the S-100 bus. My objective, both in designing the interface and writing this article, is to reduce the problem to its simplest and most essential elements.

I learn easily and enjoy the learning more when I am working on a specific application, rather than merely reading technical material or doing routine experiments. Therefore, this discussion is offered as a simple I/O (input/output) interface design that will allow the nonhardware-type person to build a working interface and gain some basic understanding of the functions of hardware in a microcomputer. This is not intended to be a straight hardware tutorial; additional study in some areas may be required to fully understand what is happening.

Intel 8255 Description

The 8255 is one of a later group of interface integrated circuits which Intel Corp introduced to support the 8080 and related processors. It is a general purpose program-

.....
Use of large-scale integration parts forces a modular approach to a hardware design problem.
.....

mable device with 24 pins that may be programmed in a variety of configurations. A programmable device can have its operating characteristics modified by a processor command. For example, in a programmable serial interface, a single output command can set data rate, number of stop bits, and parity status.

In a parallel interface part like the 8255, a single output command can define how the 24 programmable I/O pins are to be used. Such uses include input, output, handshaking, and interrupts. The 8255 is normally set up so that its control register looks like an I/O port to the processor. The processor sends a specific data byte to that port to determine the mode of operation.

The 8255 modes are as follows:

- Mode 0: (Basic I/O) Each group of 12 I/O pins may be programmed in sets of 4 and 8 to be input or output.
- Mode 1: (Strobed I/O) Each group of 12 I/O pins may be programmed to have 8 lines of input or output with the remaining 4 pins in each group being used for handshaking and interrupt control signals.
- Mode 2: (Strobed Bidirectional Bus I/O) This is a bidirectional bus mode which uses 8 lines for a bidirectional I/O bus and 5 lines for handshaking.

In addition, there is a bit set and reset feature that allows the setting and resetting of any 1 of 8 output bits

PIN CONFIGURATION

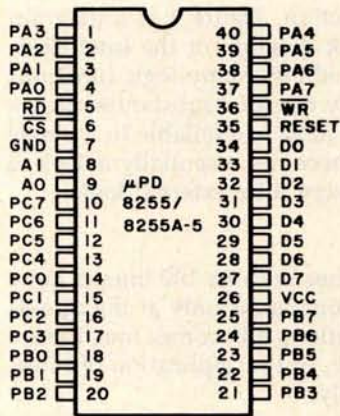

PIN NAMES

D7-DO	DATA BUS (BI-DIRECTIONAL)
RESET	RESET INPUT
\overline{CS}	CHIP SELECT
\overline{RD}	READ INPUT
\overline{WR}	WRITE INPUT
AO-A1	PORT ADDRESS
PA7-PA0	PORT A (BIT)
PB7-PB0	PORT B (BIT)
PC7-PC0	PORT C (BIT)
VCC	+5V
GND	0V

BLOCK DIAGRAM

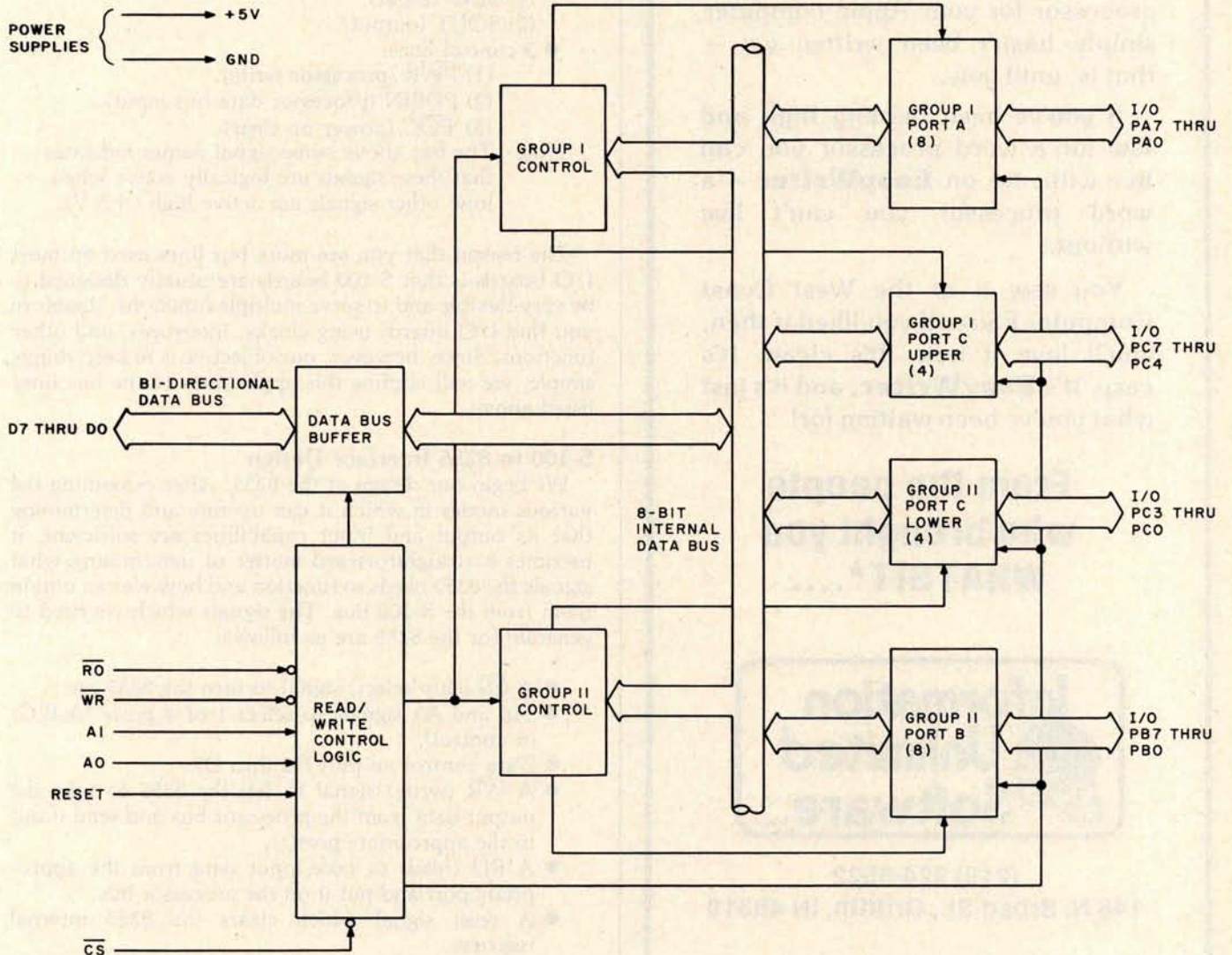

Figure 1: Configuration and names of pins of the Intel 8255 programmable peripheral interface and block diagram of its functional parts.

Writin' easy
with
EasyWriterTM
a
word processor
for your
Apple II

Let's face it, there are many good word processing programs for other micro computers -- they're almost a dime a dozen. But a good word processor for your Apple computer simply hasn't been written yet -- that is, until now.

If you've been hunting high and low for a word processor you can live with, try on **EasyWriter** -- a word processor you can't live without.

You saw it at the West Coast Computer Faire. If you liked it then, you'll love it now. It's clean. It's easy. It's **EasyWriter**, and it's just what you've been waiting for!

From the people
who brought you
WHATSIT*....



(219) 924-3522
146 N. Broad St., Griffith, IN 46319

WHATSIT is a trademark of Computer Headware
EasyWriter is a TRADEMARK OF Cap'n. Software

using a single output instruction. Figure 1 is a diagram showing pinouts and a block diagram of the Intel 8255. As can be seen, the 8255 combines many logic functions which would have previously required substantial design effort themselves. Since the 8255 is available in a single package form, however, it becomes essentially a 1-piece parallel interface requiring very little external logic.

S-100 Bus Description

At first glance, the S-100 bus with its 100 lines is quite overpowering. However, if one looks only at the signals needed for a specific application, it becomes much more understandable. For example, in the application of interfacing the 8255, we need only:

- Lower 8 address lines (A0 thru A7).
- 8 data-in lines (DI0 thru DI7).
- 8 data-out lines (DO0 thru DO7).
- 2 status lines:
 - (1) SINP (input).
 - (2) SOUT (output).
- 3 control lines:
 - (1) $\overline{\text{PWR}}$ (processor write).
 - (2) PDBIN (processor data bus input).
 - (3) $\overline{\text{POC}}$ (power on clear).

Note: The bar above some signal names indicates that these signals are logically active when low; other signals are active high (+5 V).

The reason that you see more bus lines used on most I/O boards is that S-100 boards are usually designed to be very flexible and to serve multiple functions; therefore you find I/O boards using clocks, interrupts, and other functions. Since, however, our objective is to keep things simple, we will confine this application to the bus lines listed above.

S-100 to 8255 Interface Design

We begin our design at the 8255. After examining the various modes in which it can operate and determining that its output and input capabilities are sufficient, it becomes a straightforward matter of determining what signals the 8255 needs to function and how we can obtain them from the S-100 bus. The signals which we need to generate for the 8255 are as follows:

- A $\overline{\text{CS}}$ (chip select) signal to turn the 8255 on.
- A0 and A1 signals to select 1 of 4 ports (A,B,C, or control).
- Data control on pins D0 thru D7.
- A $\overline{\text{WR}}$ (write) signal to tell the 8255 to take the output data from the processor bus and send it out to the appropriate port(s).
- A $\overline{\text{RD}}$ (read) to take input data from the appropriate port and put it on the processor bus.
- A reset signal which clears the 8255 internal registers.

Our problem becomes how to generate these signals using the S-100 bus lines defined above.

Text continued on page 129

A hot collector's item.
(from the popular series which appeared in BYTE)

\$8.00

BYTE BOOKS

Ciarcia's Circuit Cellar

BY STEVE CIARCIA



ISBN 0-931718-07-4

\$8.00

Buy this book at
your favorite com-
puter bookstore
or direct from
BYTE BOOKS.™

Add 60¢ per book for
postage and handling

The marvelous
computer projects that
Steve Ciarcia has constructed in his
cellar are explained in detail so that you
can make your microcomputer perform the same
useful functions. Each article is a complete tutorial,
presented in such an easy-going style that even
beginners can understand and enjoy.

BYTE BOOKS™

"BOOKS OF INTEREST TO COMPUTER PEOPLE"

70 Main Street Peterborough, New Hampshire 03458

Turning computer programmers into computer composers!

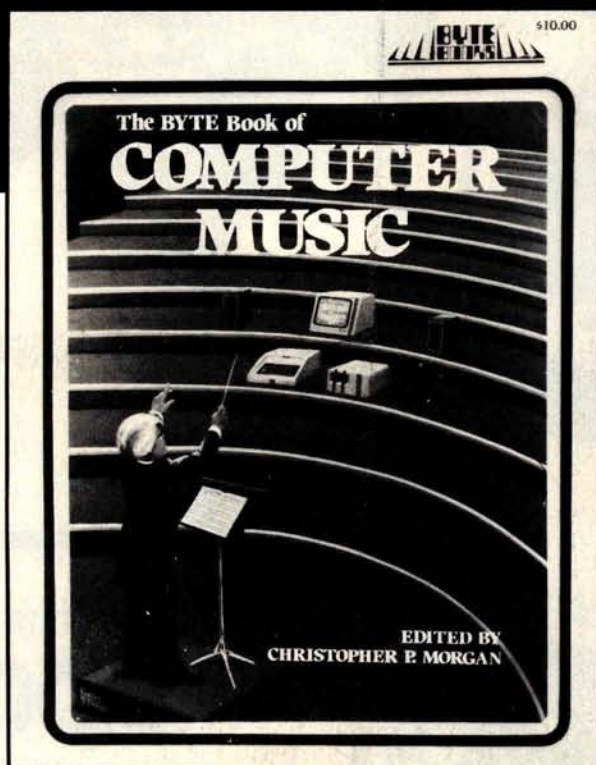

For the first time:
Hard-to-obtain
computer music
material has been
collected into one
convenient, easy-to-
read book.

The BYTE Book of
Computer Music com-
bines the best from
past issues of BYTE

magazine with exciting new material
of vital interest to computer experimenters.

The articles range from flights of fancy about the reproductive systems of pianos to Fast Fourier transform programs written in BASIC and 6800 machine language. Included in this fascinating book, edited by Christopher P. Morgan, are articles discussing four-part melodies, a practical music interface tutorial, electronic organ chips, and a remarkable program that creates random music based on land terrain maps!

ISBN 0-931718-11-2

\$10.00

Buy this book at your favorite computer book
store or order direct from BYTE BOOKS
Add 60¢ per book for postage and handling



"BOOKS OF INTEREST TO COMPUTER PEOPLE"

70 Main Street Peterborough, New Hampshire 03458

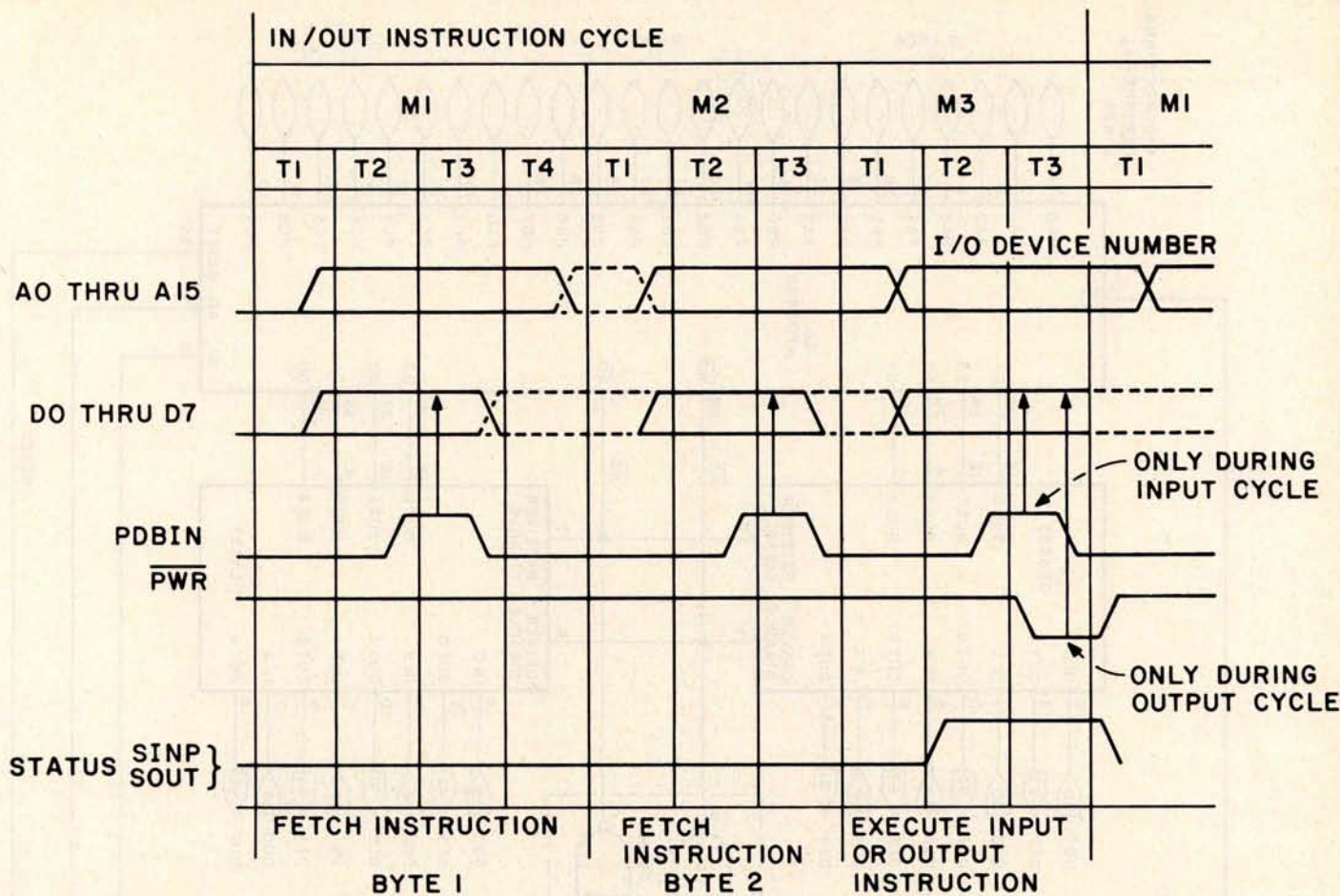

Figure 2: Timing diagram showing signals on the S-100 bus during a data transfer instruction.

.....
 An understanding of timing diagrams is essential in designing any hardware interface.

Chip Select Signal

The CS (chip select) signal is basically an on/off signal for the 8255. To avoid stray data being output or input when not desired, the 8255 device is kept disabled until the processor commands that the data be input or output through one of the 8255's ports. To do this, we must understand the definition of the S-100 bus signals which we need to use. This is best explained through the use of a timing diagram as shown in figure 2.

In most respects the S-100 bus timing is based on the 8080 processor signals. These diagrams indicate the state of the bus lines with respect to time and their interaction with each other. Most confusing, at first glance, are the data and address signals which appear to be high and low at the same time. This, of course, merely represents the idea that some of the bits may be high and some may be low when valid and active.

Starting at the bottom of the timing diagram, we see that the S-100 status signals SINP and SOUT are inactive in a low-logic state anytime except during the third machine cycle of an input or output instruction, respectively. By using a simple OR gate (such as the one shown

as IC2a in the circuit diagram of figure 3), we can turn on the 8255 programmable peripheral interface whenever the SINP or SOUT signal is high. The inverters IC1a and IC1b are used for convenience and to minimize the number of integrated circuit packages used. They also serve as bus receivers, allowing these signals to drive other circuitry on the same board.

The SINP and SOUT signals could be used to turn on the 8255 every time the processor executes an input or output instruction; however, we want the 8255 to pass data only when it is specifically addressed. To be more exact, we want the 8255 to take action only when a specific port on it is addressed by the processor. Therefore, we need to know when the processor is addressing one of these ports.

The upper and lower bytes of the address bus lines will contain the address of the I/O port during the third

Table 1: Power supply connections for integrated circuits in figure 3.

Number	Type	+5 V	GND
IC1	74LS04	14	7
IC2	74LS00	14	7
IC3	DM8131	16	8
IC4	DS8833	16	8
IC5	DS8833	16	8
IC6	μPD8255	26	7

Figure 3: Schematic diagram of an interface circuit using the 8255 device. All numbered connections refer to pins on the S-100 bus. A suitable power supply is assumed, with connections for integrated circuits given in table 1.

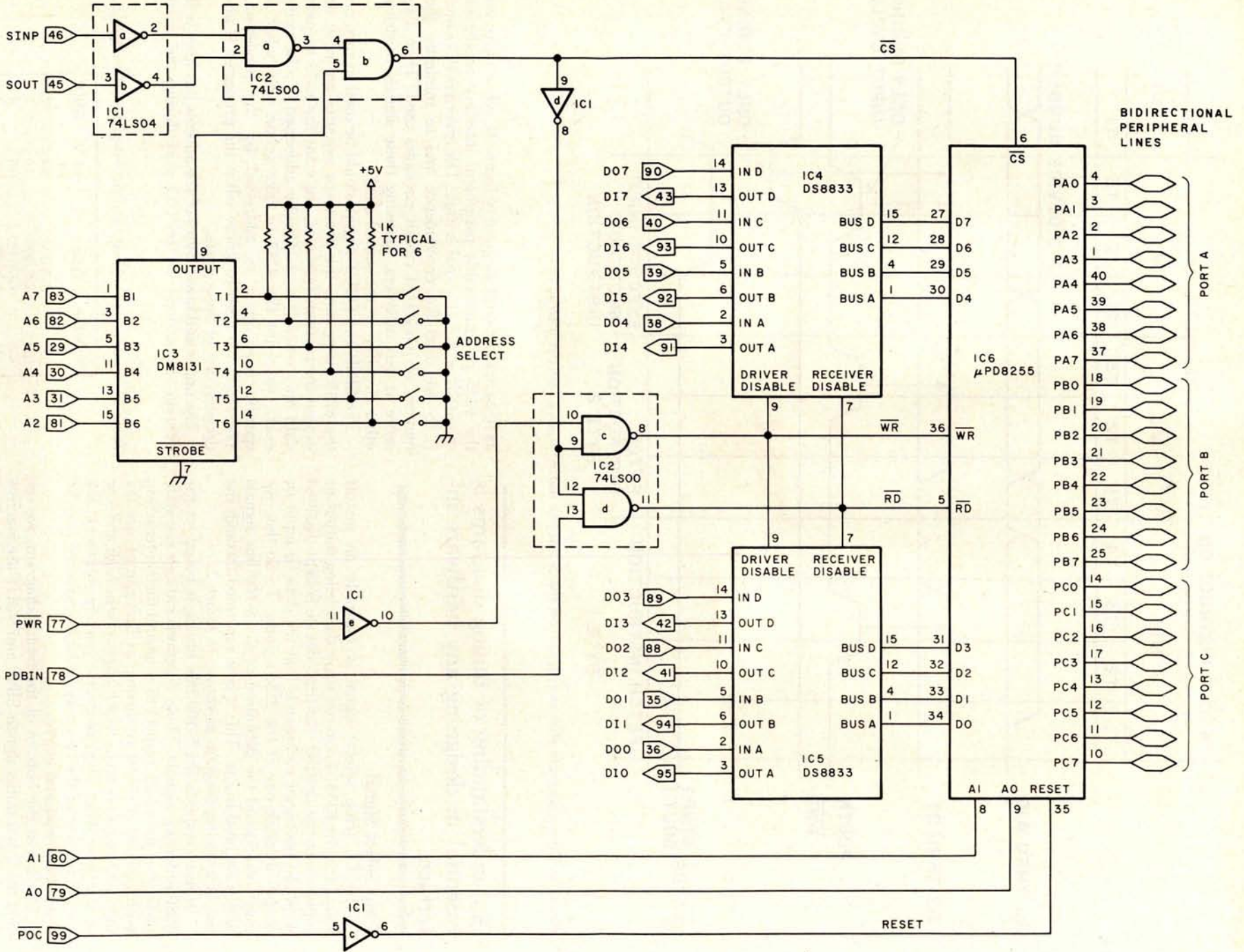

WHEN THE FUN AND GAMES ARE OVER you shouldn't have to surrender to the built-in limitations of your microcomputer. With **Outpost 11**, you won't. When it's time to get down to business, **Outpost 11** performs like a soldier. It's a ruggedly-built unit which will do much of your serious computing in a stand-alone mode. And so much more. Consider: develop your own software using available **BASIC** or **STRUBAL+**; collect, process and store data from remote sensors; batch data to or from a host computer to cut time-sharing costs; or, communicate with a remote host on-line in an interactive mode; add on communications and control modules; run a small automation control system; integrate with a distributed processing system; etc.; etc.; etc. All this and more at only **\$2,595**, suggested retail price. See **Outpost 11** at a dealer listed or write us for the name of a dealer near you.

TANO Corporation,
4301 Poche Court West,
New Orleans, La. 70129



THE SERIOUS MICROCOMPUTER



Dealers: ATLANTA, GA, Magaro and Associates — 404-252-6609, Professional Indexing — 404-572-4177 • BEAVERTON, OR, DataTools International — 503-645-4604 • BEND, OR, Control Industries — 503-389-1969 • COOKEVILLE, TN, Cumberland Computers — 615-526-7651 • DADE CITY, FL, Sabatelli Computer System Inc. — 904-567-7777 • DALLAS, TX, Eclectic Corp. — 214-358-1307 • DES MOINES, IA, H. Allen Hanna — 515-283-5130 • ELK GROVE VILLAGE, IL, Kramer DataPower Inc. — 312-894-0554 • GREENVILLE, SC, Plus Inc. — 803-242-9090 • HOUSTON, TX, Eclectic Corp. — 713-228-7798 • IDAHO FALLS, ID, Great Plains Computer Co. — 208-529-3210 • LONG BEACH, CA, CTI Data Systems Inc. — 213-426-7375 • MOBILE, AL, Railway Express — 205-661-8889 • NEW ORLEANS, LA, TANO Corp. — 504-254-3500 • NEWTON CENTRE, MA, Daner-Hayes Inc. — 617-969-4650 • PARKER, CO, Western Marketing Assoc. — 303-841-2788 • SALT LAKE CITY, UT, Home Computer Store — 801-484-6502 • SAN JOSE, CA, PBC Associates — 408-377-7001 • SEAFORD, DE, Robert Underwood — 302-629-8438 • SEATTLE, WA, Empire Electronics — 206-244-5200 • WALTHAM, MA, Computer Mart Inc. — 617-899-4540 • WESTFORD, MA, Thorstensen Labs — 617-692-2051 • ONTARIO, CANADA, Combined Systems — 416-549-2900 • GOUDHURST, KENT, ENGLAND, Warren Woodfield Assoc. Ltd. — 05-803-590 • DEALER INQUIRIES INVITED — 504-254-3500. TWX 810-591-5229

machine cycle of an I/O instruction. Therefore, what we want to do is decode the lower 8 address lines continuously. When one of the ports on the 8255 is selected, we want an *enable* signal which we can combine, using a logical AND, with the status signal to turn on the 8255.

A simple method of decoding the address bus is to use a comparator (such as the 6-bit comparator 8131) which will take the enable pin (pin 9) low when the input signals from the bus match the pattern set as the port address. In this case, we are using only the upper (most significant) 6 bits of the port address, since the lower 2 bits will be used to select 1 of 4 ports on the 8255 itself.

We can set up the port address by tying the appropriate lines on the 8131 comparator to either high or low-logic levels as required to match the address. We now have circuitry which will provide a \overline{CS} (chip select) signal whenever the processor is in an input or output instruction cycle, and whenever any of the port numbers assigned to the 8255 have been addressed by the processor.

Address Lines A1 and A0

As can be seen, pins 9 and 8, carrying low-order address signals A0 and A1, can now be tied directly to the lines A1 and A0 on the S-100 bus. This will allow the processor to select port A, B, C, or control function.

Data Transfer

We have now enabled the 8255 at the appropriate time. The remaining task is to supply the data to the data pins on the 8255 or retrieve the data from the appropriate data pins on the 8255 when the processor is doing an output or

input instruction with this port.

The data pins on the 8255 are bidirectional (ie: they will take data from the bus and output it to the appropriate port when the \overline{WR} signal is active, or will take data from the port and put it on the bus data lines when the \overline{RD} signal is active). Since the S-100 bus is divided into 8 unidirectional lines of *data in* (DI0 thru DI7) and 8 unidirectional lines of *data out* (DO0 thru DO7), we need a means of tying both of these sets of lines to the 8 data pins on the 8255 and selectively enabling either the S-100 data input or data output bus lines.

An easy way to accomplish this is with the 8833 bus transceiver integrated circuit which can be connected as shown in the circuit diagram of figure 3. When pin 9 on the 8833 is active, the data will be passed from the data output bus to the 8255, and when pin 7 is active, the data will pass from the 8255 to the data input bus of the processor. The S-100 bus provides 2 simple signals with which to achieve this result.

The \overline{WR} Signal

The \overline{PWR} signal, as shown on the timing diagram (figure 2), will go low when valid data is presented on the data output lines. We can use this signal to enable the 8833 bus transceivers and to strobe (send a pulse to) the 8255 pin \overline{WR} to pass the data to the appropriate output port.

The \overline{RD} Signal

Conversely, we see from the timing diagram that the S-100 signal \overline{PDBIN} is active in a high-logic state when valid data can be accepted on the data input line. We can use this signal to generate the \overline{RD} signal for the 8255 to pass the data from the appropriate 8255 input ports to the data pins, and to enable the 8833 bus transceivers so that the data is passed directly to the data-in bus in the processor.

One other provision which we want to include in our design is that the \overline{RD} and \overline{WR} signals should not be allowed to go active unless the \overline{CS} (chip select) signal is also active. This provision is primarily for the purpose of keeping extraneous data which might be on the 8255 data lines from being transferred to the data-in (DI) bus at any time that the \overline{PDBIN} signal is active. We can achieve this by using the AND gates IC2c and IC2d to generate the \overline{RD} and \overline{WR} signals *only when* the 8255 has been selected *and* the appropriate \overline{PWR} or \overline{PDBIN} signal is simultaneously active.

Reset Signal

This leaves us with one simple signal which is needed by the 8255. Since the 8255 can start in an undefined state when power is first supplied to it, a reset signal is necessary to bring it to a known state for further use. Fortunately the S-100 bus provides us with a very convenient POC (processor on clear) signal that can be tied through an inverter to the reset pin. This arrangement will apply a reset signal to the 8255 whenever power is applied to the processor.

We have now designed a simple but powerful interface circuit. As you can see, the parts count of 6 integrated circuits is quite low. The circuit could conceivably be put on a simple piece of perforated circuit board and hung onto an existing S-100 board. The total cost should not exceed

Now learn the electronics of microprocessing.

Enjoy the challenge and excitement of learning about microprocessing hardware — how it functions and how to repair it — by actually building your own equipment as you learn.



Heath H-8 Computer and H-9 Video Terminal

National Technical School's Microcomputer Division offers three such learn-by-doing courses that you can enjoy at home, in your spare hours. Each combines clear, concise lessons with Heath and NTS-designed digital equipment — a combination our students tell us makes for "lively" home study. Find out more about these valuable NTS Microcomputer Courses. Send today for our colorful 65-page catalog — it's FREE!

No obligation. No salesman will call. Approved for veteran training.

NATIONAL TECHNICAL SCHOOLS

TECHNICAL TRADE TRAINING SINCE 1905
Resident and Home-Study Schools
4000 South Figueroa St., Los Angeles, Calif. 90037

Clip And Mail Today!

NATIONAL TECHNICAL SCHOOLS Dept. 252-109
4000 South Figueroa Street • Los Angeles, California 90037
Please rush your FREE 65-page color catalog

Name _____
Address _____
City _____
State _____ ZIP _____

Check if interested in G.I. Bill information.
 Check if interested ONLY in classroom training in Los Angeles.

Get Ready to Make Your Own Magic

Announcement I. The first eight Personal Programs[®] from Aladdin Automation are waiting for you now at your neighborhood computer retailer or direct from Aladdin.

Now you can get your full share of Aladdin magic in every one of these Personal Programs[®]:

Math-Ter-Mind[®] A delightful, educational learning experience for your pre-school child. Watch the smile on your child's face as a correct answer makes the mathematician smile on the screen before you. A nursery song also serves as a reward for learning elementary addition and subtraction. With Aladdin's Math-Ter-Mind[®] your child's pathway to learning will be fun-filled . . . for both of you. Math-Ter-Mind[®]. The first release from the Aladdin Education[®] Series. (nursery song currently available only on Apple II[®] program)

Lunar Lander In a controlled descent, you're just seconds away from your first landing on the cold, forbidding surface of the moon. As you navigate your delicate spacecraft downward to the safety of Moonbase, you must be ever watchful of the dangers rising to meet you with each passing moment: a fuel level fast approaching zero; deadly meteor showers that come from any direction, at any time; sheer-faced rock cliffs and rough terrain; choosing the correct landing pattern and rate of descent. Aladdin's Lunar Lander. Your chance to reach out and touch the stars . . . without leaving the safety and comfort of your own chair. The first release from the Aladdin Simulation[®] Series.

Craps All eyes in the casino are on you. The dice are in your hands. Lady Luck sits at your shoulder, whispering . . . "Just one more time. Try your luck just one more time." You throw . . . and watch the dice tumbling on the screen. With Aladdin's Craps you play against the computer, so it's awfully tough to win. But when you do, it's an experience you're likely never to forget. Craps. An exciting, heart-pounding Personal Program[®]. The first release from the Aladdin Las Vegas[®] Series.

Mastermind A challenging game of intrigue, centuries old, that will give you full chance to test your powers of logic, deduction and reason. And test them you will, as you try and solve the computer's puzzle, using clues as they're provided one-by-one. You control the degree of difficulty in this classic Personal Program[®] that offers one simple, yet all-consuming challenge: beat the Mastermind in a direct, one-on-one battle of wits. Aladdin's Mastermind. The first release from the Aladdin Old Favorites[®] Series.

Tic-Tac-Toe Five different levels of difficulty allow a person of any age or skill to take part in this relaxing, enjoyable game that can act as a learning tool, as well. Level I, for example, is suitable for children and is excellent also for teaching simple mathematics. The computer plays just about perfectly at Level V. Just about, that is, so go ahead and take your best shot. See if you can beat the computer in this traditional favorite of young and old alike. Tic-Tac-Toe. Another first release from the Aladdin Old Favorites[®] Series.

Jungle Island[®] Shipwrecked in a raging storm at sea, miraculously you survive only to find yourself stranded on a seemingly deserted jungle island. Without food, water or supplies of any kind, you begin to try and find your way to safety. The computer will be your eyes and ears as you explore your jungle island and all the mysteries and dangers that lie in wait for you. Jungle Island[®]. A captivating first release from the Aladdin Adventure[®] Series.

Stix[®] Aladdin's Stix[®] can be played with 2 to 5 piles of sticks and between 1 and 19 sticks in each pile. The object: to be the one to pick up the last stick. Sounds simple? Yes, but you're playing against the computer. Take heart, though, because you can control the degree of difficulty in this update of the ancient game of Nim. Stix[®]. Another first release from the Aladdin Old Favorites[®] Series.

Super Pro Football[®] Here's your chance to be more than just an armchair quarterback. With Aladdin's Super Pro Football[®] you can replay any Super Bowl game, from the first, between Green Bay and Oakland, to last year's classic victory by Pittsburgh over Dallas. For once you can turn back the clock and go for that one big play that made the difference between victory and defeat in pro football's biggest game of all. Super Pro Football[®]. The first exciting release from the Aladdin Super Pro[®] Series.

Visit your neighborhood computer retailer or contact Aladdin direct to get your full share of the magic in Announcement I, the first eight Personal Programs[®] from Aladdin Automation.

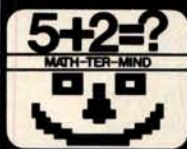

Math-Ter-Mind[®]



Lunar Lander

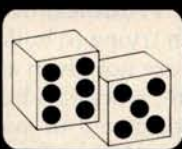

Craps



Mastermind

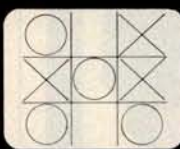

Tic-Tac-Toe



Jungle Island[®]

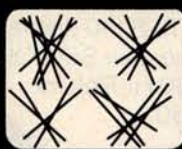

Stix[®]



Super Pro Football[®]

Welcome to the All-New World of Aladdin. And Get Ready to Make Your Own Magic

Circle 3 on inquiry card.



ALADDIN AUTOMATION, INC.
A DIVISION OF
ALADDIN COMPUTER CORP.

3420 Kenyon Street, Ste. 131, San Diego, CA 92110

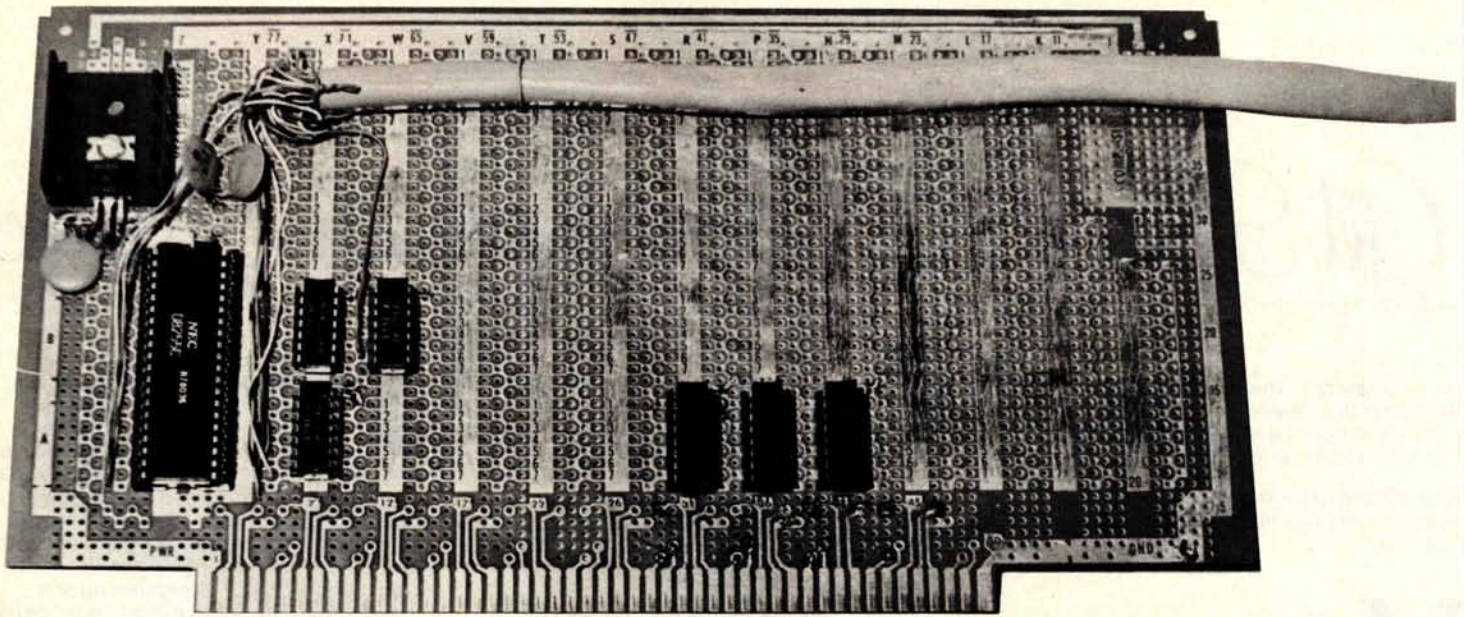

Photo 1: The author's prototype of the interface circuit, built on an S-100 prototype board. The bus transceiver and decoding integrated circuits are located on the bottom of the board. An extra 7400 NAND gate package was added for a special application.

Any 1 line on the S-100 bus must be connected to only 1 TTL integrated circuit on any 1 circuit board.

\$20. This mounting would not be advisable, due to space and maintenance problems. I would recommend using an S-100 prototype board such as one provided by Vector Electronics, which has provisions for a voltage regulator plus power and ground distribution buses on board.

The wiring can then be done point-to-point with wire wrap. There will also be plenty of available room and power for additional circuitry on board. Circuits for other functions would be very easy and economical to add, since we have already provided for data bus transceiving, and we can use many of the same bus interface integrated circuits to add additional circuitry to the board.

One caution — be aware that the S-100 bus expects to see only 1 TTL (transistor-transistor logic) "fan-out" load per board, which means that any given bus line must be tied to the input of *only 1* TTL device on the board. The bus line should not be driving 2 or more TTL devices simultaneously. Therefore, if additional circuitry uses the same bus signals, a bus receiver (7404 hex inverter) or driver (8T97 3-state buffer) must be used between the bus lines and the board circuitry.

Check-Out and Troubleshooting

One problem in trying to build other people's designs is that usually you are not given any troubleshooting information. Therefore, when it is built and does not run, you have to learn it inside out to make it run. You do learn a lot in the process, but a few guidelines, such as the following, can speed up the process considerably:

- Buy a computer with front panel lights and switches. Although manufacturers seem to be drifting away from making true front-panel controls, they are invaluable if you are going to do any hardware design or debugging. A single-step capability alone can help a great deal, but for my money give me as many switches and lights as possible.

It's **sub** LOGIC for graphics!

3D GRAPHIC SOFTWARE

for Apple II, TRS-80, 8080 and Z80, M6800, and BASIC.

Plus **Graphic Drivers** for Dazzler, Matrox ALT-256 and 512, and Vector Graphics.

HARDWARE

Matrox ALT-256 and ALT-512 S100 displays, and the new SubLOGIC 50/T80 Hi-Res for TRS-80.



We're open 9 to 6, Monday thru Friday, central time. Give us a call.

The engineering & graphics people

(217) 359-8482

sub LOGIC
Box V, Savoy, IL 61874

“..... fresh off the drawing board”.

(at a price you won't believe!!!)



THE BASE 2 MODEL 800 IMPACT PRINTER

SPECIFICATIONS

PRINTING METHOD

7 wire dot matrix, bi-directional, impact

PRINT AREA

8.0 inches (203 mm)

THROUGHPUT SPEED

60 lines per minute

LINE SPACING

6 lines per inch

COLUMN CAPACITY

72, 80, 96, 120 or 132

switch or program selectable

CHARACTER HEIGHT

.104 inches (2.6 mm)

CHARACTER WIDTH

.08 inches (2.0 mm) at 80 col.

PAPER WIDTH

9.5 inches maximum

RIBBON

.5 inch (13 mm) cartridge (5M chars)

INPUT/OUTPUT PROVISIONS

- a) RS-232
- b) 20 ma current loop
- c) IEEE - 488 type
- d) Centronics* parallel

BAUD RATES

fifteen rates from 110 to 19,200

CHARACTER FONT

5x7 96 character ASCII

LINE BUFFER

two lines plus space for second character font

SIZE

3 inches high (75.2 mm)

10 inches deep (254 mm)

14 inches wide (355.6 mm)

WEIGHT

9 pounds (4.1 Kg.)

OPERATING CONDITIONS

40°-120°F (4°-49°C)

10%-90% relative humidity

POWER

115 VAC or 230 VAC (switch select)

50 or 60 Hz

EXTERNAL CONTROLS

- power on-off
- self-test
- baud-rate
- line/buffer length
- I/O mode select

OPTIONS

- "M"—2K RAM buffer
- "S"—high speed paper advance and graphics
- "T"—tractor feed

UNIT PRICING

standard MODEL 800	\$ 499
option "M"	\$ 50
option "S"	\$ 50
option "T"	\$ 50

(By the time you read this, Base 2 will have commenced volume shipments of the MODEL 800. We regret that we cannot accept responsibility for any inconvenience this causes our competitors.)

Dealer and distributor inquiries invited

base 2. inc.

P.O. Box 3548 • Fullerton, Calif. 92634
(714) 992-4344

CA residents add 6% tax

MC/BAC accepted • FOB — U.S. destination

**WE ARE KNOWN FOR OUR PROMPT,
COURTEOUS SERVICE**

TELETYPE MODEL 43

- 4320 AAA (TTL interface) \$985
- 4320 AAK (RS232 interface) \$1,085
with transformer to operate on 50Hz, 220v, installed
inside cabinet add \$50
We stock paper and ribbon for the Teletype Model 43

**PET, NEC SPINWRITER, DIABLO, CENTRONICS
and TRS-80 now available**

- HAZELTINE 1500** (assembled only) \$945
- 1510 \$1,085
- with 50Hz, 220v current adaptation \$100
- also available with Danish, German or French
character sets add \$60

- INTERTUBE SUPER BRAIN** \$2,885
- Dual Z80, dual floppy double density, 64K RAM,
4Mhz., CP/M, FORTRAN, COBOL, BASIC,
Assembler, Language. Contained in Intertube II.

- INTERTUBE II** \$800

MARINCHIP SYSTEMS

M9900-CPU-S-100 COMPATIBLE.

Network operating system, PASCAL, Extended precision commercial BASIC, FORTH, META & applications package. Complete kit and DISCEX software \$550; Assembled \$700. We configure systems to meet your budget & your needs. Hard Disk interface (with software) available.

- IMS MEMORY, 16K Fully static, 250 ns** \$280

TEI S-100 Mainframes

- 12 slot — MCS 112 \$433
- 22 slot — MCS 122 \$609
- These mainframes are completely assembled, tested
and contain everything required for plug-in operation.

- TARBELL Floppy Disk Controller** \$255
- Other Tarbell products available.

- KONAN HARD DISK CONTROLLER** \$1,550
- S-100 compatible, plugs into S-100 mainframe.
Controls 1-4 disk drives.

- IMS 5000 SERIES,
COMPLETE Z80 SYSTEM** \$2,170
- 2 I/O ports, 1 K EPROM bootstrap loader, double
density, dual 5 1/4" disks, S-100, 12 slot mainframe.
A new rising star! No waiting.

- PER SCI FLOPPY DISK DRIVES**
- 277 DUAL DISK, Single Sided \$1,210

- SIEMENS DRIVES**
- 8" Double Density, Shagart Compatible \$420

- MODEM: "THE CAT" from Novation** \$190
- Originate/Answer. 300 baud.

TO ORDER: We ship within 24 hours after receipt of certified check, money order or cashiers check. Credit cards: add 4%. Personal checks: allow ten days. \$12 shipping for terminals. \$3 for memories and modem. New York residents include sales tax. Prices and availability subject to change without notice.

— WE EXPORT TO ALL COUNTRIES —
— OVERSEAS CALLERS USE (212) 448-6298 ONLY —

We have no reader inquiry number. Please call or write.

JOHN D. OWENS ASSOCIATES INC.

12 SCHUBERT STREET (New Address)
STATEN ISLAND, NEW YORK 10305

DAY, EVENING, WEEKEND, HOLIDAY CALLS WELCOME!
(212) 448-6283 (212) 448-6298

- Get an extender board so that you can place your circuit board where you can get at it. For tracing circuits, checking power supplies, and other general debugging, it is indispensable.

- Test power supply connections to the circuit board before plugging integrated circuits into their sockets. (Use sockets!) Plug in the integrated circuits and recheck power and ground on each one. Then single-step through an output instruction using one of the I/O port numbers you have assigned to the 8255.

When the *out* status light on the front panel (or on a logic probe you are holding on pin 45 of the S-100 bus) comes on, the processor is in the output phase of its instruction cycle and you have static conditions to check out the circuitry. By looking at the circuitry you can see that CS should be low, WR should be low, and there should be some data on the data pins of the 8255 (ie: either highs or lows, but not open circuits). If these conditions do not exist, trace back through the circuit to the bus and find the problem.

- Once you are able to output data to the 8255, you can proceed to check it out according to specifications given in the application data. For a start, you can output the hexadecimal value 94 to the control register port, which will set port A for input and port B for output. Then you can try input and output commands as you would a normal port.

You will probably experience some frustrations in trying to make the interface work. However, when you finish you will probably know more about how your computer works than you ever thought possible.

Applications

Typical applications for such an interface include peripheral devices where up to 24 I/O bits are required. This might be as simple as an 8-bit parallel interface needing only a strobe and acknowledge signal (which is a clearly defined mode 1 for the 8255), or as complex as the Diablo printer interface which requires 12 data lines, 6 status lines and 6 strobes. In fact, it is difficult to conceive a parallel device which could *not* be interfaced with this circuit.

In conclusion, for any interface application you have in mind, check first to see what special large-scale integration devices are available. You might find that the entire design can be accomplished through the use of one of these special parts. For more data I recommend the 8080 series applications manuals from Intel Corp, National Semiconductor, and Texas Instruments, and also Don Lancaster's *TTL Cookbook* and manufacturers data sheets on the 8833 and 8131. Good luck! ■

REFERENCES

1. *Intel MCS-80 Users Manual*, October 1977, Intel Corp.
2. Lancaster, D, *TTL Cookbook*, Howard W Sams and Co, Indianapolis, 1974.

We're about to make a new name for ourselves.

Not that the old one was so bad. As Ithaca Audio, we've made quite a name for ourselves. As the source for CPU, memory, video display and disk controller boards to upgrade other makers' mainframes and peripherals. The company that makes those neat little RAM expansion kits. And the folks behind the world's only Z-80 Pascal compiler.

But as much as we've enjoyed improving other people's equipment, we've been quietly moving towards larger endeavors, with a lot of encouragement from our customers. Listening to people's problems, as well as their needs. And, as a prime mover behind the IEEE S-100 Bus Standard, answering some really knotty questions.

One of the results is our new identity. And our first new product: the Intersystems DPS-1. An IEEE S-100 compatible mainframe with features that live up to its looks. Dependable operation to 4 MHz. Twenty-card capacity. A modular power

supply. And something no one else has — built-in breakpoints to give you a faster, more powerful tool for testing software as well as hardware. *Directly* accessible from an easy-to-use front panel that's as *reliable* as it is functional. In short, an intelligently-designed computer for the intelligent user.

There's a lot more to Intersystems. In hardware. And software. All available through the nationwide dealer network we're now assembling.

You can watch this magazine for updates. Or contact us directly for straight, friendly answers and detailed information from key staff people. Just the way you always have. Because even though we're making a new name for ourselves, we'll never forget who made it possible.

Intersystems

Ithaca Intersystems Inc.
1650 Hanshaw Road/P. O. Box 91
Ithaca, NY 14850/607-257-0190



**NEECO PROUDLY
ANNOUNCES THE
COMPUTHINK**

MINIMAX

"FULLY INTEGRATED COMPUTER SYSTEM"



MINIMAX SERIES COMPUTER



**THE MINIMAX SERIES WAS DESIGNED
TO OFFER THE MARKET MINICOMPUTER
CAPABILITIES AT MICROCOMPUTER PRICES.
COMPARE THE CAPABILITIES & PRICE!**

CONTACT NEECO FOR FULL SPECS - FREE MINIMAX MANUAL.

MEET THE MINIMAX COMPUTER

**THE MINIMAX SERIES COMPUTER WAS DESIGNED BY INDUSTRY PROFESSIONALS.
COMPARE THE PRICE AND FEATURES TO ANY OTHER COMPUTER IN ITS CLASS!**



**MINIMAX I - .8 MEGABYTE
ON LINE MINIFLOPPY STORAGE
MINIMAX II - 2.4 MEGABYTE
ON LINE 8" FLOPPY STORAGE**

**MINIMAX I - \$4495
MINIMAX II - \$5995**

PRINTER NOT
INCLUDED IN PRICE

• THE MINIMAX SERIES COMPUTER IS AN INTEGRATED, COMPACT UNIT CONTAINING THE CPU, DUAL DENSITY DISK STORAGE, 12 INCH CRT, AND FULL STYLE KEYBOARD, WITH SEPARATE NUMERIC ENTRY PAD. ALL KEYS (INCLUDING CURSOR) WITH FULL REPEAT • HYBRID 2 MEGAHERTZ 6502 CPU • 108K SYSTEM RAM (48K USER) • FASTEST FLOPPY DISK ACCESS (24K LOADS IN 4.2 SECONDS) • 16K ROM CONTAINS COMPUTHINK BASIC (AN EXTENDED MICROSOFT BASIC) WITH EXTENDED PRECISION, DOS INCLUDES COMPLETE FILE I/O WITH FULL RANDOM ACCESS, COMPLETE MONITOR WITH DEBUG & TRACE, AND TINY 6502 ASSEMBLER • COMPLETE HIGH RESOLUTION GRAPHICS WITH INDIVIDUAL DOT (240x512) POINT SCREEN ADDRESSABILITY • FULL SCREEN TEXT EDITING WITH OVERWRITE, INSERTION OR DELETION • SPLIT SCREEN/WINDOW MODES • INDIVIDUAL FIELD EDITING WITH FIELD PROTECT AND AUTO SKIP TO NEXT FIELD • DISK STORAGE SYSTEM TRANSFERS 6K PER SECOND WITH AUTO VERIFY AND PARITY CHECK • 12 INCH CRT-64 CHARACTERS BY 30 LINES. UP TO THREE PROGRAMMABLE CHARACTER FONTS FOR LANGUAGES OR SPECIAL CHARACTERS • •• SWITCHABLE 110 OR 220V OPERATION • •• HYBRID CPU IS MICROPROGRAMMABLE WITH 64 USER DEFINABLE OPCODES. CHOICE OF 800K OR 2.4 MEGABYTE DISK STORAGE • FULL SERIAL RS-232C PORT WITH PROGRAMMABLE BAUD RATES AND MODEM CONTROL SIGNAL • DEDICATED DISK PORT • PRINTER PORT SUPPORTS PARALLEL COMMERCIAL PRINTERS • 24 PIN I/O USER PORT • PAGEMATE DATABASE AVAILABLE • PLM COMPILER AVAILABLE • BUSINESS PACKAGES AVAILABLE • COMPLETE DIAGNOSTICS & SCHEMATICS INCLUDED • COMPLETE USER MANUAL INCLUDED

**SPECIAL DEALER PRICING AVAILABLE ON DEMONSTRATION
MINIMAX AND SOFTWARE PACKAGES TO QUALIFIED
SELECTED DEALERS. CONTACT NEECO FOR INFO.**

**THE MINIMAX WAS DESIGNED AND IS MANUFACTURED BY COMPUTHINK
COMPUTER CORP. DISTRIBUTED IN EUROPE AND THE EASTERN U.S. BY NEECO.**

IN ADDITION TO HARDWARE CAPABILITIES THAT ARE UNMATCHED IN THE INDUSTRY, THE MINIMAX COMPUTER SUPPORTS A COMPLETE DATA BASE SYSTEM (PAGEMATE), CONTAINING FULL STATISTICAL, SORTING, AND EDIT FUNCTIONS. A PLM COMPILER IS AVAILABLE, FULL BUSINESS SUPPORT SOFTWARE IS AVAILABLE AND MORE!—FULL DEALER SUPPORT IS AN IMPORTANT PART OF OUR MARKETING. CONTACT NEECO FOR FURTHER INFORMATION.

**THE MINIMAX IS NOW AVAILABLE FOR QUANTITY DELIVERY. DOMESTIC DEALERSHIPS AVAILABLE.
EUROPEAN DISTRIBUTORSHIPS/DEALERSHIPS AVAILABLE TO QUALIFYING COMPANIES WITH
SUPPORT CAPABILITIES. SOFTWARE HOUSES AND OEM INQUIRIES INVITED. CONTACT NEECO.**

NEECO

**NEW ENGLAND ELECTRONICS CO., INC.
679 HIGHLAND AVE., NEEDHAM, MA 02194
MON-FRI, 9:00-5:30, E.S.T.**

(617) 449-1760

TELEX 951021, ANSWERBACK "NEECO"

NEECO

PROUDLY ANNOUNCES THE NEWEST PET MICROCOMPUTERS BY COMMODORE!

PET 2001 — 32K

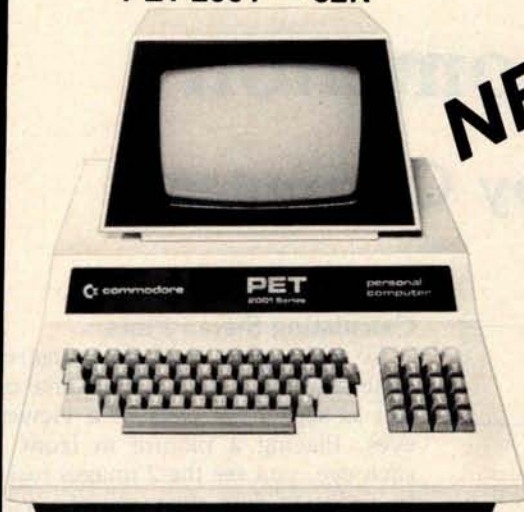

NEW!

The PET™ is now a truly sophisticated
Business System with the
announcement of these Peripherals.

The PET™, incorporated with the Floppy Disk and Printer makes an ideal business system for most professional and specialized fields: medicine, law, dental, research, engineering, toolmaking, printing, education, energy conservation, etc. The PET™ Business System as a management tool, delivers information to all levels of Business, previously attainable only with equipment many times more expensive. The PET™ Business System is one of the most cost efficient business tools

today. It offers a wide range of applications from logging management strategy in major corporations to organizing accounts and inventory control of small businesses. Here are just a few of the cost-saving uses in the corporation, professional office or small business: stock control, purchasing, forecasting, manufacturing costing, customer records, mailing lists, etc. The PET™, Floppy Disk and Printer, a compatible business system at a reasonable price — Take a closer look at these Peripherals.

PRODUCT	DESCRIPTION	PRICE	AVAILABILITY
PET 2001—4K	4K RAM	\$ 595	IMMEDIATE
PET 2001—8K	8K RAM	\$ 795	IMMEDIATE
PET 2001—16KN (Large Keys)	16K RAM*	\$ 995	IMMEDIATE
PET 2001—32KN (Large Keys)	32K RAM	\$1295	IMMEDIATE
PET 2023 PRINTER	ROLL FEED	\$ 850	IMMEDIATE
PET 2022 PRINTER	TRACTOR/ROLL	\$ 995	IMMEDIATE
PET 2040A	SINGLE FLOPPY	\$ 895	JUNE/JULY
PET 2040	DUAL FLOPPY*	\$1295	IMMEDIATE
PET C2N	2nd Cassette	\$ 100	IMMEDIATE

*The 16K/32K (large keyboard) units do not include a cassette drive. Order C2N Cassette. 2040 Floppy Drive requires a 16K or 32K unit. 8K RAM Retrofit available July.

LARGE TYPEWRITER KEYBOARDS NOW AVAILABLE!

ALL UNITS ARE FULLY TESTED BY NEECO BEFORE SHIPMENT. ALL PET'S ARE WARRANTED (BY NEECO) FOR 1 FULL YEAR! NEECO IS A FULL CUSTOMER-ORIENTED BUSINESS. PLEASE CALL FOR ADDITIONAL INFORMATION. ALL UNITS ARE IN STOCK & READY TO SHIP. FULL SOFTWARE AVAILABLE!



COMPUTHINK .4 & .8 MEGABYTE DISK DRIVES FOR THE NEW 16/32K PETS!

DISK SYSTEMS INCLUDE DISKMON OPERATING
SYSTEM IN ROM AND INTERFACE TO 16/32 PETS!

FOR 8K PETS
(small keyboards)
.4 Megabytes of Disk
Storage for 8K PETS!
(Requires Expandamem)
400K-8S DISK SYSTEM INCLUDES RANDOM
ACCESS IN DOS-LOADS 20K IN 4 SECONDS!
24K Expandamem Memory *525
32K Expandamem Memory *615 **\$1295**

- Dual Minifloppy Drives with 200K per diskette side for total 400K/800K on line.
- 800K model accesses all 4 diskette sides via dual read and write arm system.
- Dual Density Hardware and DOS loads 20K (with verification) in 4.2 seconds complete.
- DISKMON (DOS) adds 17 commands to BASIC including Random Access and printer support.
- System comes complete with plug in internal board containing 8K RAM, DOS, and Disk Controller Hardware—Board plugs directly onto internal memory expansion pins.
- System does not utilize IEEE or USER Port, system functions directly from memory port.
- All DISKMON DOS commands reside interactively with BASIC—disk directory command and format command do not interfere with program in RAM—DOS command were designed for simplicity of use. System was manufactured for heavy commercial use.
- System installs completely in less than ten minutes—immediately ready for use.
- *1295 and *1595 prices include all hardware, DOS, complete user manual, and demo/utility diskette.
- Available software includes PLM Computer (*250), Relocatable Assembler (*70), Source-Editor Program (*70), Autolink Linking Loader (*70), and a complete Database system (Pagemate *495).
- Call or write for complete product information and specifications—User manual *10

(PRODUCT AVAILABILITY IS AUG/SEPT—CALL FOR INFO)

ALL 16/32K MODELS INCLUDE AN	400K-16N	\$1295
INTERNAL PLUG-IN INTERFACE	400K-32N	\$1295
BOARD CONTAINING DOS, 8K OF	800K-16N	\$1595
RAM, AND CONTROLLER	800K-32N	\$1595

CALL OR WRITE FOR A FREE COPY OF OUR NEW JULY CATALOG!

NEW CENTRONICS 730 PRINTER FOR PET!

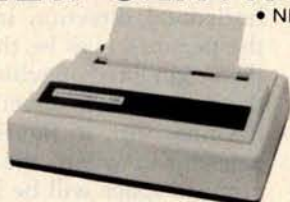

- NEWEST TECHNOLOGY FROM CENTRONICS • 50 CPS • 80 CHARACTER LINE
- 10 CPI • 7x7 DOT MATRIX • HANDLES ROLL FEED, PIN FEED PAPER • UPPER & LOWER CASE—*1099 PRICE INCLUDES INTERFACE TO IEEEPORT. AVAILABLE AUG/SEPT.

\$1099

TRS-80 USERS!—THE
MODEL 730 IS AVAILABLE FOR USE WITH
THE TRS-80. PRICE
INCLUDES CABLE **\$995**
only

WE CANNOT LIST ALL OF OUR SOFTWARE AND HARDWARE PRODUCTS
CALL OR WRITE FOR OUR *FREE* SOFTWARE/HARDWARE DIRECTORY
ALL NEECO PETS CARRY A FULL ONE-YEAR NEECO WARRANTY.

NEECO

NEW ENGLAND ELECTRONICS CO., INC.
679 HIGHLAND AVE., NEEDHAM, MASS. 02194
MON. - FRI. 9:30 - 5:30, EST.

(617) 449-1760
MASTERCARD OR VISA ACCEPTED
TELEX NUMBER 951021, NEECO

The XYZ Phenomenon

Stereoscopic Plotting by Computer

When I was small, I visited my grandmother's house on a hill in Salem, Oregon. The house was just below a peak of the steep hill, and on the peak was a large fir tree. From high in that tree, using my uncle's binoculars (not authorized for use in trees!), I could look out over Salem on a summer day and see Mt Hood floating above the horizon. Its white cone was hazy and immense. Between me and the mountain lay 60 miles of town and country, looking like artificial scenery painted on layers of glass, one stacked close behind another. The binoculars compressed perspective, just as they magnified lateral dimensions, squeezing those 60 miles of hills, ridges, and forest into what looked like about a thousand yards.

Inside my grandmother's house was another marvel, also a binocular device: a stereopticon and a huge collection of pictures to look at. The effect was just the opposite of the scene from the tree with the binoculars. A card holding 2 flat and apparently identical pictures was slipped into the frame. Holding the device by its wooden handle and slipping the cupped eyeshield over my eyes, I saw the flat pictures turn into startling solid objects in a world that lay beyond the translucent frame of the pictures, extending from arm's reach to at least the distance of Mt Hood. Some were frightening views down cliffs in the mountains of Switzerland, where my grandmother was born.

I was about 6 or 7 when I discovered the stereopticon, and was soon told that using it so much was bad for my eyes. When that pronouncement was made, the viewer was put away. However, I knew where the pictures were, and quickly

William T Powers
1138 Whitfield Rd
Northbrook IL 60062

developed a skill that was probably worse for my eyes. I learned to look at them walleyed, and to fuse the pictures without the viewer. You can learn to see the stereo pairs described in this article that way if you like; you can also do it by crossing your eyes. It takes patience and practice, since you have to uncouple the focus of your eyes from their convergence (normally, when we converge our eyes to see something close, the lenses automatically focus for near distance). In a stereo pair of pictures, all the objects are at the same distance, and you have to learn to keep them in focus independently of the convergence of your eyes. I learned to do that when I was 7, so you can probably learn to do it, too. In case it is too much of a strain, we will have a look at a simple viewer that is easy to put together. I use the viewer because it gives better depth.

Illinois in the winter of 1978 was a long way from the clear, warm summer days in Oregon in the early 1930s. However, when I bent over the drawings my computer had produced (using the objective lenses from an inexpensive pair of binoculars balanced on a pair of rulers as a viewer), and saw the tangled lines sink below the paper and stand in space above it, I felt a pang of joy that connected me instantly with that small boy in Oregon long ago. We get bigger and change shape, but the important things stay the same. That is the real reason for writing this article. It is for phenomenon fans.

Calculating Stereo Plots

To make a stereo picture, construct 2 views of the same 3-dimensional object as seen from each of a viewer's eyes. Placing a picture in front of each eye, you see the 2 images fused. In order to fuse near objects, your eyes have to converge just as for the real object, since near objects are displaced more (to the side opposite the viewing eye) in the 2 pictures, than are the actual far objects. The most natural viewing requires using 2 identical lenses, one in front of each eye, and a cardboard shield to keep each eye from noticing the wrong picture.

Stereo effects arise from image displacements left and right; in the vertical dimension, stereo pictures are essentially identical. The *size* of the vertical dimension shrinks as the distance to the object increases, but by the same amount for both eyes.

Figure 1 shows the situation from the top of the viewer's head. The actual pictures will be at some fixed distance, Z_0 , from the person's eyes or the lenses of the viewer. Letting the horizontal direction in the plane of the person's eyes be the X axis (with the origin lined up with the nose), and the Z axis be the direction away from the nose (up, in figure 1), it can be determined where the image of any point in space will be in the picture.

The coordinates of a point (X,Z) are shown in figure 1. This point forms the farthest corner of a right triangle, the other far corner being directly ahead of the person's left eye, and a distance E left of the Z axis (for this eye, E will be a negative number, being to the left). The length of the far side of the right triangle is thus (X-E).

The corresponding point on the paper is (X1, Z0). X1 is the X position

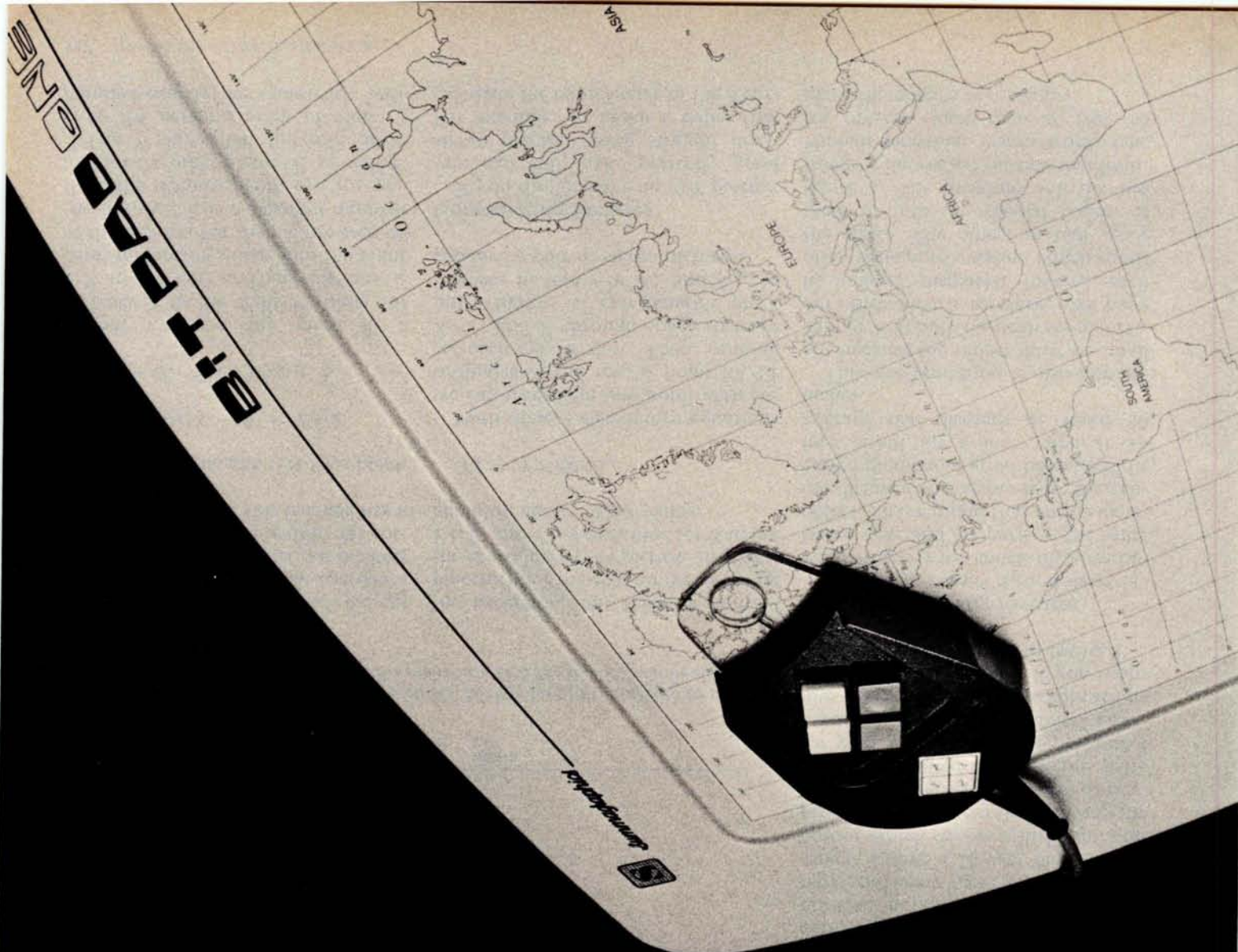

Bit by bit, the world is coming to Bit Pad One.

Bit Pad One™ is the small, low-cost digitizer that lets you add a graphics or menu capability to any data processing system. It's perfect for data entry, CRT cursor control, games, mapping and countless business applications like order entry and inventory control. Bit Pad One is small in size, but big in reliable capability.

The 11" x 11" active area has a resolution of 0.005" which is comparable to digitizers found in expensive turnkey graphic design systems. Best of all, Bit Pad One is designed and built by Summagraphics, the leading manufacturer and OEM supplier of data tablets and digitizers. Bit Pad One. It's bringing digitizing down to earth.

Central Office: 3785 Varsity Dr., Ann Arbor, MI 48104, (313) 973-1710.
Western Office: 1102 West 17th St., Santa Ana, CA 92706, (714) 541-8261.
European Office: 14 rue de l'Ancien-Port, 1201 Geneva, Switzerland.
phone 022/31 39 40.
Circle 342 on inquiry card.

35 Brentwood Ave., Box 781
Fairfield, CT 06430
(203) 384-1344.
Summagraphics
corporation



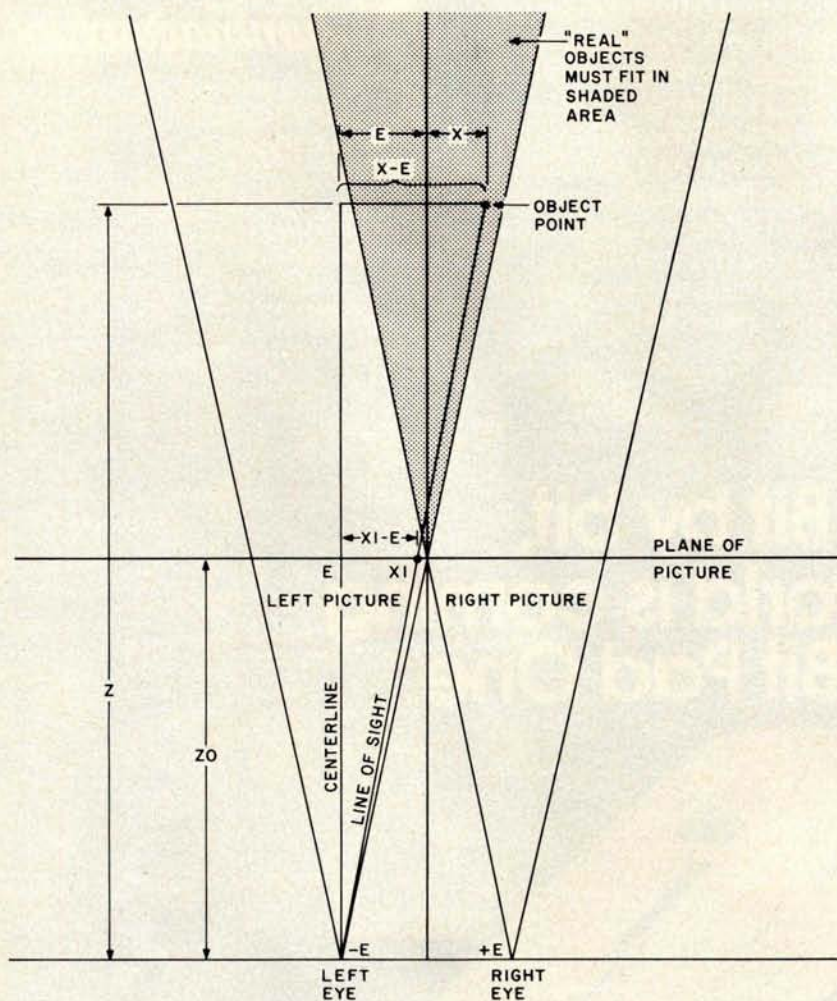

Figure 1: Geometry of generating stereo pictures. Each point of the object to be pictured is projected along the line of sight to the plane in which the picture will be drawn.

where the line of sight to (X, Z) pierces the picture. A smaller right triangle is formed, with $(X1, Z0)$ as the farthest corner and $(E, Z0)$ as the other far corner. The far side of this triangle has a length of $(X1 - E)$.

By similar triangles, we thus have:

$$(X1 - E)/(X - E) = Z0/Z$$

or

$$X1 = (X - E) \times Z0/Z + E$$

That transfers any point at a distance X to the right of center (or $-X$ to the left) and any distance Z from the person's nose into the plane of the picture. For the picture seen by the left eye, E is a negative number (half the distance from eye to eye), and for the other picture E is positive.

The Y dimension (up and down from the person's point of view) is handled exactly the same way, with

the exception that there is no displacement of the eyes above or below the centerline of the picture; in effect, E is 0, and Y is substituted for X in the equation above. That yields:

$$Y1 = Y \times Z0/Z$$

With these 2 elementary equations we can transform any point with coordinates X, Y, Z into a point $X1, Y1$ for each eye to view. Then, running X, Y , and Z through space to trace out a figure, we can generate the 2 pictures in terms of $X1$ and $Y1$, to produce a pair of stereo pictures.

Constructing Pictures

If you do not have an X, Y plotter, you can still make perfectly good stereo pictures using straight lines. For example, to make a cube, first calculate the coordinates of the 8 cor-

ners of the cube as X, Y, Z coordinates. Then apply the above equations to convert each X, Y, Z triple into an $X1, Y1$ pair. Do this twice, once with E set to about -1.25 inches and then with it set to $+1.25$ inches (a typical interocular [between the eyes] distance is about 2.5 inches, close enough). $Z0$ is set to the viewing distance you plan to use, or the focal length of the viewing lenses. Plot the 2 sets of points on graph paper. A simple BASIC program will make the conversions easy.

Finally, and with great care, use a felt-tipped pen or pencil and ruler to connect the points that correspond to edges of the cubes in the 2 views; straight lines are transformed into straight lines. Voilà! View the pictures stereoscopically, and you have a 3-dimensional cube. Thick lines work better than thin ones, but try to keep the width uniform.

If you have a high-resolution graphic display such as the Apple computer has (and if the display is not too nonlinear), you can make plots and view them directly on the screen. I have a 15 year old X, Y pen plotter which shakes a little, but still produces fairly accurate lines, and the program given here is for that device. I have computed a few stereo pairs for your amazement. The program I used can make 3-dimensional Lissajous figures with a few modifications you can easily enhance, if you wish. This program is shown in listing 1.

Tips on Producing Pictures

It is difficult to get a good stereo effect if there is too much distance between near and far parts of the same object. I have found that with a viewing distance of 6 inches from the generated pictures, a good object will fit into about an 8 inch cube at an average *real* distance of about 30 inches.

This size limitation is also important because the object must be small enough that both eyes can see all of it. An object that is too large will have its images displaced toward each other enough to overlap, which spoils the effect. The object in real space must fit into the shaded region of figure 1. The program will do odd things if figures get outside that limit. Human binocular vision works best for objects closer than 20 feet, so place the objects accordingly.

"How I Spent My Summer Vacation"



"My father brought home a computer. It was fun. The computer was like a teacher. I learned how to do graphs and lots of other things too. I had a really good time."

Sonja Richman—Age 9

Sonja used Program Design educational software on her TRS-80. PDI programs and games teach subjects like programming, reading, and grammar. Kids and adults like PDI because the programs keep them involved and entertained while they learn.

PDI has courses for all ages. Some of Sonja's favorite courses are **Graph Builder**, **Story Builder**, and **Memory Builder: Concentration**. For her parents, we have courses like **Step By Step** to teach them programming and **Spelling Builder**.

Guaranteed-to-load cassettes for APPLE, PET, TRS-80 Level II, ATARI

Send for our flyer. And see Program Design software at participating Computerlands and other fine computer stores.



Program Design, Inc., 11 Idar Court, Greenwich, CT 06830 (203) 661-8799

Listing 1: Stereo plotting program in North Star BASIC. The picture coordinates are first generated and stored, then the stored list of coordinates is scanned and plotted.

```

10 REM PROGRAM FOR GENERATING 3D STEREO IMAGE PAIRS
20 REM WILLIAM T. POWERS, DECEMBER 1978
30 REM
40 REM
50 REM SET Z0 TO FOCAL LENGTH OF VIEWING LENSES OR
60 REM VIEWING DISTANCE FROM EYES IF NO LENSES USED
70 REM
80 Z0=6
90 H=100\K=3.141592654/180\K1=100\K2=2*3.141592654\0=2.5\M1=0
100 DIM M$(3000)\!%#9F2
110 REM * * * * *
120 REM DEVICE 31= PEN LIFT
130 REM DEVICE 30= Y OUTPUT
140 REM DEVICE 29= X OUTPUT #1
150 REM DEVICE 28= X OUTPUT #2
160 REM * * * * *
170 REM
180 REM * * * * *
190 REM SET PLOTTING PARAMETERS
200 REM * * * * *
210 REM
220 OUT 31,0\Z9=SIN(SIN(SIN(1)))
230 INPUT "X, # CYCLES: ",N1\N1=N1*K2/100
240 INPUT " PHASE: ",B1\B1=B1*K\IF B1<0 THEN B1=B1+K2
250 INPUT " SIZE: ",S1\S1=S1/2
260 INPUT " POSITION: ",D1
270 INPUT "Y, # CYCLES: ",N2\N2=N2*K2/100
280 INPUT " PHASE: ",B2\B2=B2*K\IF B2<0 THEN B2=B2+K2
290 INPUT " SIZE: ",S2\S2=S2/2
300 INPUT " POSITION: ",D2
310 INPUT "Z, # CYCLES: ",N3\N3=N3*K2/100
320 INPUT " PHASE: ",B3\B3=B3*K\IF B3<0 THEN B3=B3+K2
330 INPUT " SIZE: ",S3\S3=S3/2
340 INPUT " POSITION: ",D3
350 INPUT " LINEAR,K4*T: ",K4
360 INPUT "SIZE FUNCTION: S(1+K5T). K5= ",K5
370 Q=127\GOSUB 960\INPUT "SET PEN, HIT RETURN",AS
380 REM
390 REM * * * * *
400 REM FIGURE GENERATION
410 REM * * * * *
420 REM
430 FOR E=-0/2 TO 0/2+.01 STEP 0
440 OUT 31,0\Z9=SIN(SIN(SIN(1)))
450 P1=B1\P2=B2\P3=B3\T=0\D=0\M1=0
460 G=1+K5*T
470 Z=S3*G*SIN(N3*T+P3)+D3+K4*T
480 X=S1*G*SIN(N1*T+P1)+D1
490 Y=S2*G*SIN(N2*T+P2)+D2
500 GOSUB 770\T=T+D\IF T>100+D THEN 510 ELSE 460
510 GOSUB 570\Q=128\NEXT\OUT 31,0\ GOTO 220
520 REM
530 REM * * * * *
540 REM PLOT STORED IMAGE
550 REM * * * * *
560 REM
570 P=0\OUT 31,0\FOR J=1 TO 10\Z9=SIN(1)\NEXT
580 FOR J=1 TO M1-1 STEP 2
590 X=ASC(M$(J,J))-128\Y=ASC(M$(J+1,J+1))-128
600 REM ADJUSTMENT FOR TWO'S COMPLEMENT OUTPUT
610 IF X<0 THEN X=256+X\ IF Y<0 THEN Y=256+Y
620 REM ANALOG OUTPUTS
630 OUT 29,X\ OUT 30,Y\ IF P=1 THEN 690
640 REM IF PEN IS UP, OUTPUT X AND Y SEVERAL TIMES
650 REM TO ALLOW D/A CONVERTERS TIME TO CATCH UP.
660 REM PAUSE BEFORE LOWERING PEN.
670 FOR L=1 TO 15\OUT 29,X\OUT 30,Y\OUT 28,Q\NEXT
680 FOR L=1 TO 5\Z9=SIN(1)\ NEXT\P=1
690 OUT 31,40\OUT 28,Q\NEXT\RETURN
700 REM

```

Listing 1 continued on page 146

The maximum horizontal dimension in inches for an object at a distance of Z inches is:

$$X_{\max} = 2.5 \times (Z - Z_0) / Z_0.$$

For $Z_0=6$ inches, as in my system, this works out to a width of 10 inches at 30 inches distance, 20 inches at 54 inches distance, and 30 inches at 78 inches distance.

How to View Stereo Pairs

The easiest viewing method is to cross the eyes or let them diverge (either will work, although the picture turns inside out if you cross the eyes). This requires practice, and I suppose it is bad for the eyes. (I am not an ophthalmologist and neither was my grandmother.) It is less of a strain to use a pair of lenses; here is a way to do it.

To make my kludge-variety viewer, I unscrewed the objective lenses from a pair of Squire 7 by 35 binoculars. These lenses have about a 6 inch focal length. You can measure the focal length with a ruler, measuring from the lens to a sharp image of a distant scene on a sheet of paper. Support the 2 lenses above the plane where the generated stereo pair is to be placed, the distance being the focal length of the lenses. This distance becomes Z_0 in the equations, in inches. Any pair of lenses about 1 to 2 inches in diameter and having about a 4 to 10 inch focal length will do. View with your eyes as close to the lenses as possible.

I supported the lenses by laying 2 rulers across 2 stacks of books, far enough apart to support the lenses without obscuring too much of the field. I taped the ends of the rulers to pieces of cardboard, so they could be moved as a unit with the lenses supported over the gap. Sliding the 2 lenses together and apart permits fairly major adjustments to be made. This will accommodate different interocular distances to get the best stereo effect with the least effort. Of course, if you have steady hands you can just hold the lenses.

It is essential to have the pictures aligned in the vertical direction, which is done by tilting your head left or right, or by moving a lens slightly up, while moving the other slightly down. Once the images are fused in your perception, you can tolerate

ALTOS COMPUTER SYSTEMS PROUDLY ANNOUNCES

SUN-SERIES

ACS8000-6

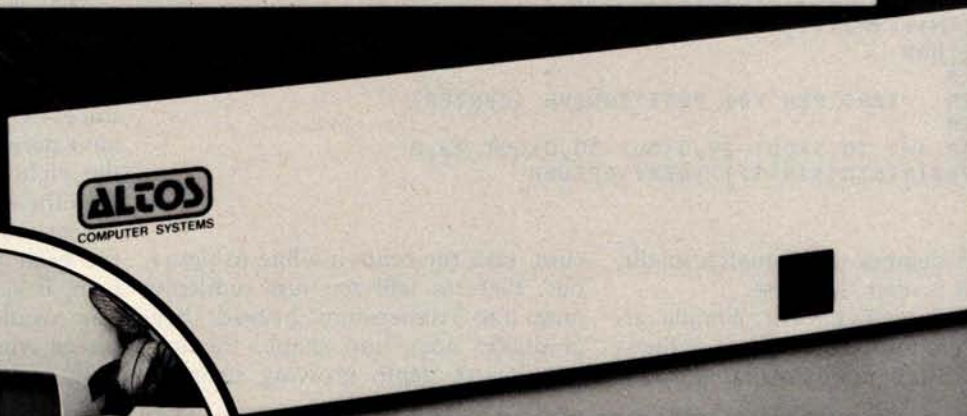
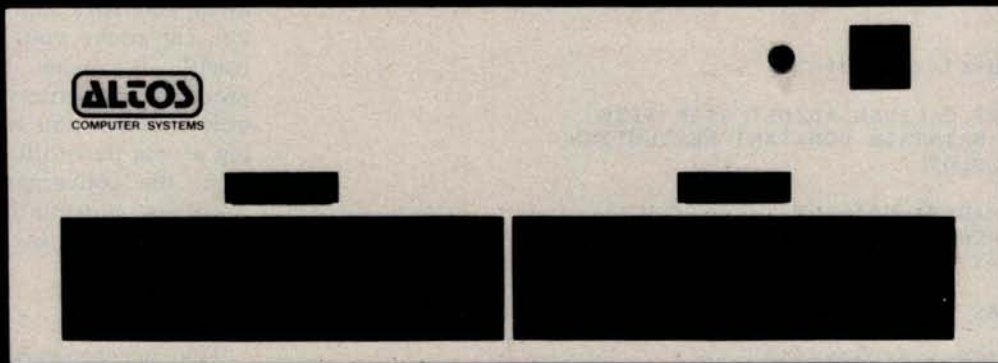

THE VERY FIRST

Double Density Z80 Micro-Computer
plus Twin 8" Floppies
plus 14.5Mb Winchester Disk
for under \$9,500!

And more! 4 user CP/M® for under \$12,000!

*CP/M is a registered trademark of Digital Research, Inc.

ALTOS COMPUTER SYSTEMS, LEADER IN SINGLEBOARD TECHNOLOGY
DOES IT AGAIN WITH ITS SINGLEBOARD ACS8000-6. TOTAL BUSINESS COMPUTER

HIGH TECHNOLOGY AGAIN

The new ACS8000-6 single board computer is packed with ultra-high technology: Z80 double-density computer, 208Kb of high speed RAM, Floppy-disk and Winchester Hard Disk controllers, DMA, 6 serial/2 Parallel I/O, 32 bit floating point processor . . . All on One Board, fully socketed, fully documented reliable and maintainable.

ADVANCED MULTI-USER SOFTWARE

Our new ALTOS Multi-User Executive (AMEX) supports four independent CP/M compatible programs in any of six languages: Basic, Fortran, Cobol, Pascal, APL, C, and a wealth of complete business application packages.

WINCHESTER MASS STORAGE

We're staying with Shugart for both floppies and Winchester hard disk. Why? Simple, low price, solid reliability and they're our next door neighbor. Our single board computer supports up to 4 Mbytes of floppies and 58 Mbytes of Winchester running under AMEX.

MINI PERFORMANCE FOR 1/2 COST

Prices you will love. Entry level ACS8000-6 Hard Disk System \$9,450
2 users \$10,670, 4 users \$11,960,
AMEX separate at \$250.

AVAILABLE NOW!

Call for your nearest Altos dealer. (408)
244-5766. Telex 171562 ALTOS SNTA.
Circle 6 on inquiry card.

ALTOS

COMPUTER SYSTEMS

2338-A Walsh Avenue
Santa Clara, Ca. 95050

Listing 1 continued:

```

710 REM      * * * * *
720 REM      STORE IMAGE POINTS AS ASCII STRING
730 REM      * * * * *
740 REM
750 REM      NEXT TWO LINES PLOT STEREO POSITION
760 REM
770 U=Z0/Z
780 X=(X-E)*U*K1\ Y=Y*U*K1
790 REM
800 REM      NEXT 3 LINES ADJUST STEP SIZE
810 REM      TO MAINTAIN CONSTANT RESOLUTION
820 REM      ON PLOT
830 REM
840 D=D+(2.8-ABS(X-L1)-ABS(Y-L2))/K1
850 IF D<0 THEN D=0
860 L1=X\ L2=Y
870 REM
880 REM      BIAS X AND Y FOR CONVERSION TO ASCII
890 REM
900 X=INT(X+128)\Y=INT(Y+128)
910 M1=M1+1\M$(M1,M1)=CHR$(X)\M1=M1+1\M$(M1,M1)=CHR$(Y)
920 RETURN
930 REM
940 REM      ZERO PEN FOR POSITIONING (CENTER)
950 REM
960 FOR J=1 TO 5\OUT 29,0\OUT 30,0\OUT 28,0
970 Z9=SIN(SIN(SIN(1)))\NEXT\RETURN

```

about 5 degrees of mismatch in tilt, but that is *after* they fuse.

Do not be impatient. Simple artificial pictures, which lack richness of detail and nonbinocular distance

clues, take the brain a while to figure out. Pictures will not just suddenly jump into 3 dimensions. Instead, they gradually ooze into shape, the impression of depth growing stronger

the longer you look. It gives interesting insight into the depth perception process used by the brain. Once the depth appears, you can look away and back and not lose it, and you can move your eyes all around freely. It seems that the brain gradually constructs a model of the object. When you switch from looking at one part to looking at another part, the convergence of the eyes becomes automatic, anticipating what is required for various parts of the picture.

Program Notes

The accompanying program of listing 1 is written in North Star BASIC. In order to make the plotting pen move fast enough to make clean traces without spreading the ink, I have done the process in 2 stages: first the picture is generated and stored; then the stored list of X,Y coordinates is scanned and plotted. This is done for each picture, left and right, in turn. If you want to plot directly (as you would do on a video display screen where plotting speed is essentially instant), you can eliminate the storage phase (GOSUB 770 in line 500) and substitute a call to the plotting subroutine. You would also delete the GOSUB 570 in line 510. The plotting subroutine would consist of lines 770 and 780 followed by the commands to plot X and Y, and a RETURN statement — much simpler.

My analog output is generated with a Cromemco D+7A board, which can produce 7 independent outputs. The digital-to-analog converters (DACs) have only 8 bits of resolution, and my plotter can plot about 100 points per inch. To get the maximum possible resolution I have used 2 analog outputs for the X axis. One, device 28, simply puts out either -2.56 V or +2.56 V; the other, device 29, puts out the same range of voltages representing the variations in Y. This makes it possible to plot each picture, left and right, with the full resolution of 256 elements. The recorder has a voltage differential input, so device 28 goes to the negative input and device 29 to the positive input.

In lines 370 and 510 you will observe a variable Q that is set to 127 for the left picture and 128 for the right picture. A value of 127 output to a converter corresponds to the maximum *positive* voltage of 2.55V.

↓ Make your own interface easily for Apple II¹ and Superkim² with Vector 4609 Universal Plugbord!

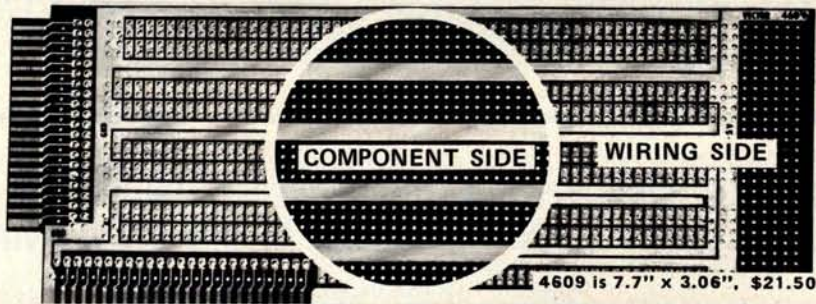

HIGH CAPACITY:

22 16-pin DIPs or 2 40-pin plus 18 sixteen-pin DIPs.

VERSATILE

.1 inch grid; .042 inch diameter holes.

- Extra I/O connector—gold plated.

- Extended length! Extra area! No interference.

- Wrap wire or solder.

- Quick solder mounting of any IC sockets.

- Hot tinned 2 ounce copper power & ground buses between IC leads for easy connection.

Vector Electronic Company
INCORPORATED

12460 Gladstone Avenue, Sylmar, California 91342
phone (213) 365-9661, TWX (910) 496-1539

1 T. M. APPLE COMPUTER, Inc. 680679

2 T. M. MICROPRODUCTS

Radio Shack introduces its second TRS-80™ computer breakthrough. A small-business computer for people who like to pay less than the "going price".

Why Radio Shack's "going price" is so much lower

There's TRS-80 Model I. Systems start at \$499. Last year they started at \$599, but now we're down the learning curve while others are just starting up. This ad, of course, is not about Model I. It's about Model II. Model II systems start at \$3450. It's an all 8" floppy disk system: one built in, room for three more. True 12" monitor, twice the size of the IBM 5110, for example. Twice the operating speed of Model I. Upper and lower case. New state-of-the-art 76-key keyboard. Level III expanded BASIC. And here's what's so incredible: comparable systems (like IBM 5110) cost roughly 33% to 66% more. We said we'd tell you why; it's a mix of three possibilities: (1) they have higher selling costs, (2) they have higher manufacturing costs, (3) we have lower gross margins.

A small business may be a small part of a large business, right?

Most businesses, small or large, have a tendency to buy too much computer for their job. We learned about this with

TRS-80 Model I; in fact Model I is too little computer for many business applications. So we designed Model II to be "just enough computer" for most micro/mini applications. And here's a promise: we'll sell you what you need, not less, not more, and you will SAVE MONEY.

Does a retailer belong in the business-computer business?

The competition would like you to believe computers can't be sold over the counter like typewriters. They're right! Business computers like TRS-80 Model II have to be sold where computers and software are sold, where computers are serviced, where computer advice is available directly from the manufacturer. That, friend, is exactly what Radio Shack is all about.

How we sold over 100,000 TRS-80 Model I Systems

This is probably the most interesting computer story never told. We did not know—repeat NOT know—there was a

big market for personal computers. So we put 20 people on the job. Shortly thereafter we had over 700 people on the job. The over 100,000 system sales came from getting off our behinds FAST and meeting demand by building computers (instead of talking about them).

Radio Shack deserves to be your small-computer company!

Simply because we offer 5-figure computing power at a 4-figure price—with five business software packages ready to "go to work" immediately—with your existing personnel. Plus, modular design means easy expandability with plug-in printers, additional disk drives and more! You can order a TRS-80 Model II (or I) in over 7300 locations worldwide. And, over 100 USA Computer Sales/Service centers are ready to stand behind your computer with service (and training classes, if you wish). There's so much to tell about TRS-80 II, we urge you to come in today and get all the facts, firsthand!

* Retail prices may vary at individual stores and dealers.

½-Megabyte Basic System \$3450*

2-Megabyte System \$8737*

(as illustrated)



Radio Shack®
The biggest name in little computers™

Mail to: Radio Shack, Dept. CE-203
1300 One Tandy Center, Fort Worth, TX 76102

"yes"

- Send me your new 1980 TRS-80 Computer Catalog
 I'd like more facts — have a representative call me

Name _____

Title _____

Company _____

Street _____

City _____ State _____ Zip _____

Applied to the *negative* recorder input, this biases the pen to the left. A value of 128 (hexadecimal 80) corresponds to -2.56 V, and biases the pen to the right.

Lines 770 and 780 do the actual conversion from X,Y,Z coordinates to X,Y stereo coordinates. You will notice that the equation for the stereo value of X is not quite the same as the above equation; the added constant E has been left off. This results in the picture being plotted relative to the point straight ahead of the relevant eye in the X direction; this permits the highest possible resolution. The auxiliary X output from device 28 inserts the missing value of E into the plot. If you are plotting on a high-resolution video display, you can write the *first* statement in line 780 as:

$$X = ((X - E) \times U + E) \times K1$$

and eliminate all statements involving Q (in lines 370, 510, 670, and 690). At the same time, the scale factor K1 (line 90) should be adjusted to reflect the actual number of points per inch on the display. I ran the recorder at 2 V per inch, which works out to K1 =

100; if I had not used device 28, I would have run at 1 V per inch and used K1 = 50.

The plotting parameters are set in lines 220 to 360. For X, Y, and Z the program asks for the number of full sine wave cycles to be plotted, the phase angle at which each variable is to start (in degrees), the size of each plot in inches (from left edge to right edge, bottom to top, or near to far), and the position of the *center* of the range of variation of each plot.

For the Z axis only, there is also a

linear term that is requested: the constant K4 sets it. For every plot, the parameter T runs from 0 to 100, and the Z coordinate has the amount $K4 \times T$ added to it. Thus if K4 is 1, the Z coordinate will have 100 inches added to it by the time the plot finishes. If the Z size is set to 0, the Z coordinate will move linearly away from the viewer during the plot.

The last item requested is a size factor. The size of the pattern for all 3 variables is multiplied by a variable G, computed from $G = 1 + K5 \times T$,

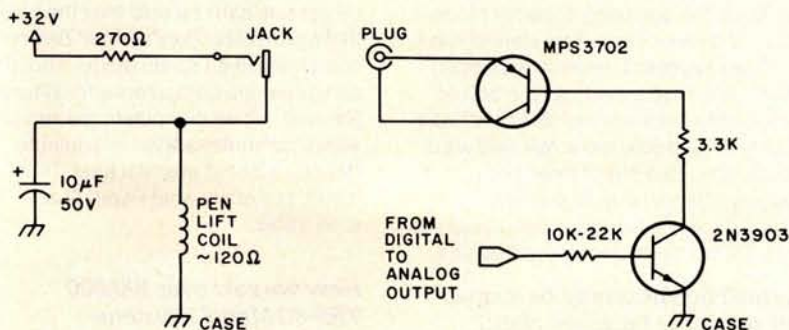

Figure 2: Pen lift circuit for use with digital-to-analog converter driver. The PNP transistor serves as switch; NPN driver transistor amplifies low-level input for high-voltage switch.

∞ INFINITE BASIC ∞™

**RELOCATABLE MODULES FOR THE TRS LEVEL II AND DOS SYSTEMS
LOAD ANY OR ALL MODULES. FOR \$49.95 THE CORE PACKAGE INCLUDES:**

∞ MATRIX PACKAGE ∞

Over 30 BASIC commands including:

- ∞ Matrix Read, Inverse, Transpose, and Identity. Simultaneous Equations!!!
- ∞ Add, Subtract, or Multiply Scalars, Vectors, or Multi-dimension arrays!!!
- ∞ Dynamically Reshape, Expand, Delete Arrays, Change arrays in mid-program.
- ∞ Copy array elements, set arrays to scalar, zero arrays, move arrays.
- ∞ Tape array read and write including string arrays.

FOR \$29.95 more get the ∞ BUSINESS PACKAGE ∞

- ∞ Eliminate round-off error!!! Multiple precision packed decimal arithmetic. 127-digit max. accuracy
- ∞ Binary search or sorted arrays. Insert new elements in sorted arrays!!!
- ∞ Automatic page headings, footings, and pagination. Includes forced end-of-page.
- ∞ Automatic hash for record retrieval!!! And more for your professional packages.

COMMAND PROCESSOR 'COMPROC' for \$19.95 (DOS only)

Extend DOS-AUTO command to perform multiple steps either at power-up or as a user command. Execute a script consisting of a sequence of commands or data from a BASIC command file.

REMODEL + PROLOAD for \$34.95 (Specify 16, 32, or 48K version)

REnumber any section of a program, MOver program segments, DElete program lines. Combine programs with renumber and merge. Load or save any portion of program from tape.

DISK SORT PROGRAM 'DOSORT' for \$34.95 (Specify 32 or 48K, minimum 2 disk system)

SO RT/MERGE multi-diskette sequential files. Multiple variables and keys. Includes machine language in-memory sorts, comparators and string handling.

COPY SYSTEM TAPES with 'COPSYS' for \$14.95 (Non-DOS)

∞ STRING PACKAGE ∞

Over 40 BASIC commands including:

- ∞ Left and right justify, truncate, rotate. Text justification. String centering.
- ∞ Delete or insert substring, Pack strings, Convert to upper or lower case.
- ∞ Translate characters, Reverse strings, Verify function, Number of occurrences.
- ∞ Masked string searches for simple or array variables. Encrypt or decrypt strings.
- ∞ Compress/uncompress character string arrays to 6 bits or less per character.
- ∞ AND the famous RACET machine language SORTS. Multi-key multivariable and string. Sort 1000 elements in 9 sec!!!

FUTURE ∞ ADD-ON PACKAGES ∞ will include ∞ STATISTICS ∞ INPUT/OUTPUT ∞ GRAPHICS ∞

Attn: TRS Add-On OEM's: We can support your special hardware add-ons with direct BASIC commands. System Houses: We license System House usage of ∞ INFINITE BASIC ∞ modules.

Check, VISA, M/C C.O.D.
Calif. residents add 6%

Telephone Orders Accepted
(714) 637-5016

WHEN ORDERING PLEASE
ADVISE PUBLICATION SOURCE

RACET COMPUTES
702 Palmdale, Orange CA 92665

where K5 is the size factor. If K5 is -0.01, G will range from 1 to 0 during each plot. That means the picture will start out full-size, and shrink to a point just as the plot finishes. If K5 is 0, there will be no change in size.

Use of String Variables

Some plots take many points; I have allowed for 3000, or 1500 X,Y pairs. A floating-point representation

would need 15,000 bytes of storage. That is more than I have, so I converted each variable to character format and stored the results as a character string, 1 byte per coordinate instead of 5. The function CHR\$ will convert a floating-point number between 0 and 255 to the character format needed for strings. The ASC function will perform the reverse operation. The program

scales X and Y to a positive or negative number (you must pick sizes and distances to keep this number within the range of -128 to +127 units, or 1/K1th of that amount in "real space"). This number is biased up by 128 (has 128 added to it), which is subtracted out when the stored number is recovered.

Miscellany

Before each plot begins, there is a pause to allow the pen to be set (with the positioning controls) to a point midway between the 2 pictures that will result. One run plots both pictures, the pen lifting as necessary. You will need some type of circuit to allow one analog output to operate the pen lift; mine is shown in figure 2.

Lines 840 thru 860 in listing 1 are a little feedback "circuit" that adjusts the step size in T (the parameter that runs from 1 to 100 during a plot) to maintain about 2 resolution elements of step size on the final plot. If the difference between the current and the last positions of the pen is larger than 2, the step size decreases. If the difference is less than 2, the step size increases. Rather than computing the square root of the sum of the squares of X and Y steps to get the actual step size, I merely summed the absolute values of the step sizes, which is close enough and much faster. This saves time that would otherwise be wasted plotting the same point over and over.

Even so, this is a very slow program. A plot with 6 loops in it takes about 10 minutes to store. Then a picture is plotted, and you must wait the same length of time for the second picture to be plotted. Practical production of 3-dimensional motion pictures requires a faster program.

Suitable lenses can be bought from the American Science Center, 5700 Northwest Hwy, Chicago IL 60646. The stock number is 95-697, which gets you a pair of lenses 23 mm in diameter and having a focal length of 136 mm (that gives a Z0 of 5.35 inches). The price is \$2.70. Cash orders require a minimum of \$5.00 and a flat handling charge of \$1.00, so you will want to order with a friend or get something else from this very interesting catalog. Edmund Scientific Co, 300 Edscorp Bldg, Barrington NJ 08007 also carries these items. ■

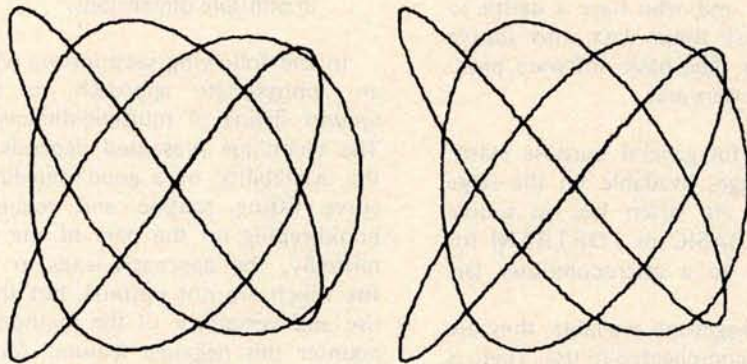

Figure 3: Plot of Lissajous pattern produced by BASIC program of listing 1, driving an analog recorder. Parameters follow in the order requested by the program. For X: cycles=3, phase=0, size=8, position=0; for Y: cycles=8, phase=0, size=8, position=0; for Z: cycles=5, phase=0, size=8, position=30, linear=0; size factor=0.

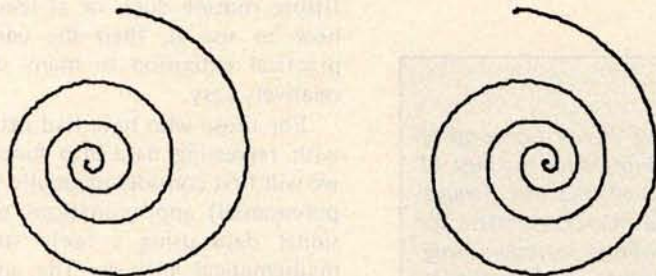

Figure 4: Spiral plot. Parameters in order are, for X: cycles=4, phase=0, size=8, position=0; for Y: cycles=8, phase=90, size=8, position=0; for Z: cycles=0, phase=0, size=0, position=30, linear=0.5; size factor=-0.01.

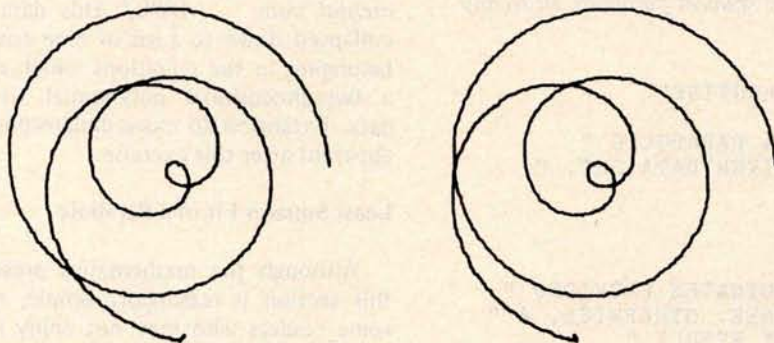

Figure 5: Plot with cardioid. Parameters are, for X: cycles=3.25, phase=0, size=9, position=0; for Y: cycles=3.25, phase=90, size=9, position=0; for Z: cycles=0, phase=0, size=0, position=30, linear=0.3; size factor=-0.03.

Curve Fitting with Your Computer

Fred R Ruckdeschel
773 John Glenn Blvd
Webster NY 14580

This article is dedicated to the small system users who are faced with multiple variable data tables and who have a desire to curve fit (regress) these data into simple functional forms. The basic software problems facing such users are:

1. The powerful general purpose statistical packages available on the large computers are often not in source code (eg: BASIC or FORTRAN) for translation to a microcomputer language.
2. If the packages are available, they are often very complicated to use. There is a human language barrier.
3. The large machine software may not be directly compatible with translation to a small machine language (eg: there may be calls for matrix inversions which are not internal functions in the small system).

About the Author

Dr Ruckdeschel is a principal scientist at the Xerox Corporation in Webster, New York, where he has been employed for the past 11 years. During this time he has been involved in physics and management. Recently he has turned his interests to microcomputers for both data acquisition and personal use. His hobbies include sailing, woodworking, digital electronics, programming, and haunting computer stores.

Listing 1: BASIC program for calculating a least squares parabolic fit to any data set having more than three points.

```
30 PRINT "LEAST SQUARES CURVE FIT ROUTINE"  
40 PRINT  
50 PRINT "THIS PROGRAM CALCULATES A PARABOLIC "  
60 PRINT "LEAST SQUARES FIT TO A GIVEN DATA SET. "  
70 PRINT  
80 PRINT "INSTRUCTIONS"  
90 PRINT "-----"  
100 PRINT  
110 PRINT "THE NUMBER OF DATA COORDINATES PROVIDED "  
120 PRINT "MUST BE GREATER THAN THREE. OTHERWISE, A "  
130 PRINT "DIVIDE BY ZERO ERROR MAY RESULT."  
140 PRINT  
150 PRINT "INPUT THE NUMBER OF DATA POINTS: ",  
160 INPUT I
```

Listing 1 continued on page 152

4. There are limitations in the types of functions fitted (eg: polynomials only) in multiple dimensions.

In the following sections we will discuss an approximate approach to the *least squares* fitting of multiple-dimension data. The technique presented depends only on the availability of a good one-dimensional curve fitting routine and requires some bookkeeping on the part of the user. Admittedly, the approach leads to statistical fits which are not optimal, but the ease of use and versatility of the method strongly counter this negative feature. An example will be given which quantitatively indicates the magnitude of the shortfall of the fit; the results are encouraging.

A significant advantage to the method to be discussed is that it is *simple*. If users understand what their one-dimensional curve fitting routine does, or at least understand how to use it, then the conceptual and practical extension to many dimensions is relatively easy.

For those who have had little experience with regressing data into functional forms, we will first consider parabolic (second order polynomial) approximations to one-dimensional data using a fairly straightforward mathematical analysis. The analysis results will then be converted into a simple computer program which will in turn be used to treat a noisy two-dimensional data set consisting of 121 data points. [*Noise results from the random fluctuation of experimental data. . . .BWL*] This data will be collapsed down to a set of nine coefficients belonging to the equations which represent a two-dimensional polynomial fit to the data. Extension to more dimensions will be apparent after this exercise.

Least Squares Fit of a Parabola

Although the mathematics presented in this section is reasonably simple, there are some readers who may not enjoy it. Those people may advance to the next section without great loss. For those interested in Nth order polynomial fits, see *BASIC Programming for Scientists and Engineers* by

THERE'S A BRAIN IN THIS BEAUTIFUL BODY.



ANNOUNCING COMPANION I & II.

Beneath this beautiful teakwood roll-top desk exterior, there beats a heart of pure Radio Shack TRS-80 Microcomputer.

But don't let the good looks fool you. This beauty's got a brain that's right at home in your office, home, classroom or laboratory.

Two versions are available; each designed around the TRS-80 system with video monitor, keyboard, cassette recorder, expansion interface, mini-disk system and printer. Both include the latest version of the TRS-80 disk operating system, disk BASIC and Level II BASIC as well as the assurance of Radio Shack's reputation, warranty and national service network.

The Companion I features 16K of memory, the TRS-80 Quick Printer I and a single mini-disk drive.

The Companion II highlights include 32K of memory, the TRS-80 tractor feed line printer and dual mini-disk drives.

Either version can be expanded to accommodate additional memory and mini-disk drives.

And we haven't forgotten the brain food either. A full set of cassettes, diskettes and paper accompanies the clear and concise instructions of the Companion User's Guide. All this brain matter comes pre-assembled in a body you can love and live with.

The perfect companions from PRODATA.

PRODATA, INC.

These packages are competitively priced at \$3,495 and \$4,995 FOB Ft. Worth, Texas, and ready for immediate delivery. We'll pay the air freight charges on all prepaid orders within the Continental U.S.A. For more information, write or call PRODATA, Inc., 98-1122 Kahapili Street, Aiea, Hawaii 96701, Telephone: 808-488-5348. Assembly Office: 3260 Lake Pontchartrain Drive, Arlington, Texas 76016. *Dealer inquiries invited.*

```

170 IF I<3 THEN GOTO 110
180 DIM X(I),Y(I)
190 PRINT
200 PRINT "THERE ARE TWO INPUT OPTIONS. ONE (1) "
210 PRINT "INPUTS THE DATA POINTS IN COORDINATE "
220 PRINT "PAIRS, AND THE OTHER (2) ALLOWS ONE TO "
230 PRINT "FIRST INPUT THE INDEPENDENT VARIABLE "
240 PRINT "VALUES, LATER FOLLOWED BY THE DEPENDENT "
250 PRINT "WHICH MODE DO YOU DESIRE? (1 OR 2): ",
260 INPUT Z
270 IF Z=2 THEN GOTO 300
280 IF Z=1 THEN GOTO 390
290 GOTO 250
300 FOR M=0 TO I-1
310 PRINT M+1,
320 INPUT X(M)
330 NEXT M
340 FOR M=0 TO I-1
350 PRINT M+1,
360 INPUT Y(M)
370 NEXT M
380 GOTO 430
390 FOR M=0 TO I-1
400 PRINT M+1,
410 INPUT X(M),Y(M)
420 NEXT M
430 REM BEGINNING OF LEAST SQUARE CALCULATION
440 A0=1\A1=0\A2=0\A3=0\A4=0
450 REM U,V,W ARE THE DESIRED COEFFICIENTS
460 U=0\V=0\W=0
470 D=0
480 FOR M=0 TO I-1
490 A1=A1+X(M)
500 A2=A2+X(M)*X(M)
510 A3=A3+X(M)*X(M)*X(M)
520 A4=A4+X(M)*X(M)*X(M)*X(M)
530 B0=B0+Y(M)
540 B1=B1+Y(M)*X(M)
550 B2=B2+Y(M)*X(M)*X(M)
560 NEXT M
570 A1=A1/I\A2=A2/I\A3=A3/I\A4=A4/I
580 B0=B0/I\B1=B1/I\B2=B2/I
590 D=A0*(A2*A4-A3*A3)-A1*(A1*A4-A3*A2)+A2*(A1*A3-A2*A2)
600 U=B0*(A2*A4-A3*A3)+B1*(A3*A2-A1*A4)+B2*(A1*A3-A2*A2)
610 U=U/D
620 V=B0*(A3*A2-A1*A4)+B1*(A0*A4-A2*A2)+B2*(A2*A1-A0*A3)
630 V=V/D
640 W=B0*(A1*A3-A2*A2)+B1*(A1*A2-A0*A3)+B2*(A0*A2-A1*A1)
650 W=W/D
660 PRINT\PRINT\PRINT
670 PRINT "FITTED EQUATION IS: "
680 PRINT
690 PRINT " Y= ",%8F4,U," ",
700 IF V>=0 THEN PRINT "+",
710 PRINT %8F4,V,"*X ",
720 IF W>=0 THEN PRINT "+",
730 PRINT %8F4,W,"*X*X"
740 REM EVALUATION OF STANDARD DEVIATION
750 S=0
760 FOR M=0 TO I-1
770 T=Y(M)-U-V*X(M)-W*X(M)*X(M)
780 S=S+T*T
790 NEXT M
800 S=S/(I-1)
810 PRINT\PRINT
820 PRINT "STANDARD DEVIATION OF FIT: ",
830 PRINT %8F4,SQRT(S)
840 PRINT\PRINT\PRINT
850 END
READY

```

W N Hubin (Prentice-Hall, Englewood Cliffs NJ, 1978).

The purpose of doing a particular one-dimensional least squares example is to show how a curve fitting routine may generally be developed using brute force (no tricks) techniques which require little deep thought, just competent algebra.

It is always possible to *exactly* fit a reasonably well-behaved data set using a carefully chosen polynomial of the proper *degree* (highest *power*). For example, if the independent continuous variable is x (eg: age), and the resultant dependent variable response is $y = f(x)$ (eg: height), it is legitimate to write (assuming that the "true" function has no poles or discontinuities):

$$y \cong f(x) = \sum_{m=0}^{M-1} a_m x^m \quad (1)$$

To be sure that this approximation works well we may have to let M become infinitely large. However, for an I component data set, (y_i, x_i) , where x_i is the particular independent variable value (eg: the age of a specific person) and y_i the particular response (corresponding height of that person), the data may be *exactly* fitted using a polynomial of degree $M-1 = I-1$.

The proof of this assertion is simple. Assume we do not know the coefficients a_m . However, for each of the I data points we have:

$$y_i = \sum_{m=0}^{I-1} a_m x_i^m \quad (2)$$

Each y_i is known. Each x_i^m is known. There are thus I (simultaneous) equations in I unknowns (the a_m), and equation (2) may be exactly satisfied with a proper (and unique) choice of a_m values (coefficients). Thus the data is fitted exactly.

Although the above conclusion is very powerful, it lacks direct applicability in many real life statistical situations. For example, if there are 20 pieces of data containing noise, it would be a little foolish to fit a 19th degree polynomial to the data. Usually the objective is to smooth out large and noisy data sets into curves having only a few descriptive constants (coefficients). We will consider here *only* the second degree polynomial (parabolic) case:

$$y \cong f(x) = a_0 + a_1 x + a_2 x^2 \quad (3)$$

The approximation sign is used, since we will usually not be able to fit the data exactly, given such a restriction on the

NEW FROM MOUNTAIN HARDWARE. THE APPLE CLOCK.

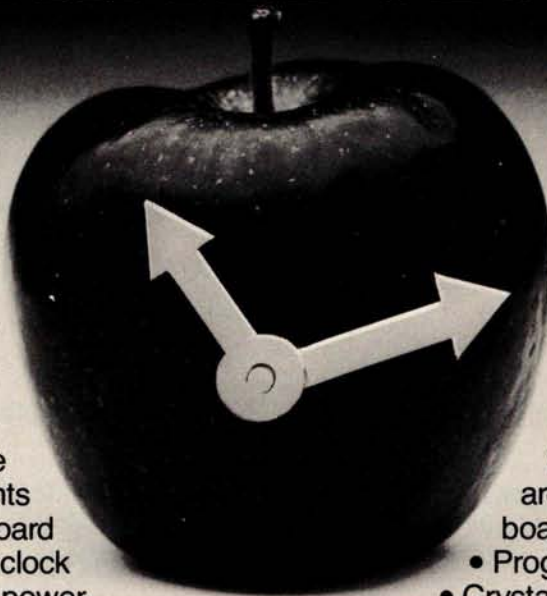

NEW UTILITY FOR YOUR COMPUTER.

Until now, there hasn't been a Real-Time Clock for the Apple II*. The Apple Clock from Mountain Hardware keeps time and date in 1mS increments for over one year. On-board battery backup keeps the clock running in the event of power outage. Software controlled interrupts are generated by the clock. That means you can call up schedules, time events, date printouts ...all in real time on a programmed schedule.

EASY TO USE.

The Apple Clock is easily accessed from BASIC using routines carried in on-board ROM. With it, you can read time and program time-dependent functions for virtually any interval. From milliseconds to days, months or a year.

PLUG IN AND GO.

Plug the Apple Clock into a peripheral slot on your Apple II and you're ready to go.

FEATURES.

- Time and date in 1mS increments for periods as long as one year.
- Software for calendar and clock routines, as well as an event timer are contained on on-board ROM.
- Program interrupts.
- Crystal controlled accuracy of $\pm .001\%$.
- On-board battery backup keeps your clock in operation even during power outage.

REAL TIME AT THE RIGHT PRICE.

At \$199 assembled and tested, it's the clock your Apple has been waiting for. And, it's available now through your Apple dealer. Drop in for a demonstration. Or return the coupon below.

A COMPLETE LINE.

Mountain Hardware also offers a complete line of peripheral products for many fine computers.

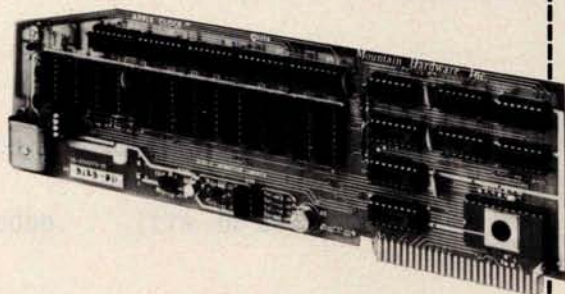

Mountain Hardware, Inc.

300 Harvey West Blvd., Santa Cruz, CA 95060
(408) 429-8600

Sounds great.

____ Send me everything I'll need to know about the Apple Clock.
____ I've got a _____ computer. Send me information.

Name _____

Address _____

City _____ State _____ Zip _____

*Apple II is a trademark of Apple Computer, Inc.

degree of the polynomial. That is, in general $y_i \neq f(x_i)$. However, intuitively we know that there must be a best choice for a_0 , a_1 and a_2 , given some fitting criteria. The criteria often used is *least squares*. We define the least squares error as:

$$E(a_0, a_1, a_2) = \sum_{i=0}^{l-1} \{y_i - f(x_i)\}^2 \quad (3a)$$

where, in this particular case,

$$f(x_i) = a_0 + a_1x_i + a_2x_i^2 \quad (3b)$$

The object is to find a choice for the a_m which gives a minimum value for E . By separately taking partial derivatives of equation (3a) with respect to a_0 , a_1 and a_2 we get the following three equations in the three unknowns, a_0 , a_1 and a_2 :

$$0 = \sum_{i=0}^{l-1} y_i - a_0 - a_1x_i - a_2x_i^2 \quad (4a)$$

$$0 = \sum_{i=0}^{l-1} \{y_i - a_0 - a_1x_i - a_2x_i^2\} x_i \quad (4b)$$

Listing 2a: Sample run of listing 1 in which the data was created using $y=x$.

RUN

LEAST SQUARES CURVE FIT ROUTINE

THIS PROGRAM CALCULATES A PARABOLIC LEAST SQUARES FIT TO A GIVEN DATA SET.

INSTRUCTIONS

THE NUMBER OF DATA COORDINATES PROVIDED MUST BE GREATER THAN THREE. OTHERWISE, A DIVIDE BY ZERO ERROR MAY RESULT.

INPUT THE NUMBER OF DATA POINTS: ?10

THERE ARE TWO INPUT OPTIONS. ONE (1) INPUTS THE DATA POINTS IN COORDINATE PAIRS, AND THE OTHER (2) ALLOWS ONE TO FIRST INPUT THE INDEPENDENT VARIABLE VALUES, LATER FOLLOWED BY THE DEPENDENT WHICH MODE DO YOU DESIRE? (1 OR 2): ?1

1?0,0
2?1,1
3?2,2
4?3,3
5?4,4
6?5,5
7?6,6
8?7,7
9?8,8
10?9,9

FITTED EQUATION IS:

Y= .0000 + 1.0000*X + .0000*X*X

STANDARD DEVIATION OF FIT: .0000

READY

Listing 2b: Sample run similar to listing 2a, but with $y=x^2$.

RUN

LEAST SQUARES CURVE FIT ROUTINE

THIS PROGRAM CALCULATES A PARAPOLIC LEAST SQUARES FIT TO A GIVEN DATA SET.

INSTRUCTIONS

THE NUMBER OF DATA COORDINATES PROVIDED MUST BE GREATER THAN THREE. OTHERWISE, A DIVIDE BY ZERO ERROR MAY RESULT.

INPUT THE NUMBER OF DATA POINTS: ?10

THERE ARE TWO INPUT OPTIONS. ONE (1) INPUTS THE DATA POINTS IN COORDINATE PAIRS, AND THE OTHER (2) ALLOWS ONE TO FIRST INPUT THE INDEPENDENT VARIABLE VALUES, LATER FOLLOWED BY THE DEPENDENT WHICH MODE DO YOU DESIRE? (1 OR 2): ?1

1?1,1
2?2,4
3?3,9
4?4,16
5?5,25
6?6,36
7?7,49
8?8,64
9?9,81
10?10,100

FITTED EQUATION IS:

Y= .0000 + .0000*X + 1.0000*X*X

STANDARD DEVIATION OF FIT: .0000

READY

$$0 = \sum_{i=0}^{I-1} \{y_i - a_0 - a_1 x_i - a_2 x_i^2\} x_i^2 \quad (4c)$$

These simultaneous equations can be solved using Cramer's Rule (see texts on matrix algebra) to give:

$$a_0 = \{B_0(A_2 A_4 - A_3^2) + B_1(A_3 A_2 - A_1 A_4) + B_2(A_1 A_3 - A_2^2)\} / D \quad (5a)$$

$$a_1 = \{B_0(A_3 A_2 - A_1 A_4) + B_1(A_0 A_4 - A_2^2) + B_2(A_2 A_1 - A_0 A_3)\} / D \quad (5b)$$

$$a_2 = \{B_0(A_1 A_3 - A_2^2) + B_1(A_1 A_2 - A_0 A_3) + B_2(A_0 A_2 - A_1^2)\} / D \quad (5c)$$

where:

$$D = A_0(A_2 A_4 - A_3^2) - A_1(A_1 A_4 - A_3 A_2) + A_2(A_1 A_3 - A_2^2) \quad (5d)$$

and:

$$A_0 = 1$$

$$A_s = \sum_{i=0}^{I-1} x_i^s / I$$

$$B_s = \sum_{i=0}^{I-1} y_i x_i^s / I$$

These equations are encoded into the program shown in listing 1. Listing 2a shows a sample run in which the relation $y=x$ was used to create the data. The program correctly interpreted the data and returned $y=x$ as the fitted function. In this example there was no x^2 term. Listing 2b demonstrates a similar test run, but this time using $y=x^2$ to create the data. Again, the program returns the proper coefficients.

Listing 2c displays a least squares fit to data generated using the function $y=x+\epsilon$, where ϵ flips back and forth between +1 and -1; very noisy data. The regression program indicates the fitted functional form to be linear with a first power (linear) coefficient near unity, and with a standard deviation approximately equal to ϵ . When the same data sets are run through a standard Nth order regression routine, the coefficient values obtained were approximately the same as shown in listings 2a and 2b. However, significantly different coefficients are obtained for the case corresponding to listing 2c. The fitted equation given by the

Listing 2c: Least squares fit to a noisy line: $y=x+\epsilon$.

RUN

LEAST SQUARES CURVE FIT ROUTINE

THIS PROGRAM CALCULATES A PARABOLIC LEAST SQUARES FIT TO A GIVEN DATA SET.

INSTRUCTIONS

THE NUMBER OF DATA COORDINATES PROVIDED MUST BE GREATER THAN THREE. OTHERWISE, A DIVIDE BY ZERO ERROR MAY RESULT.

INPUT THE NUMBER OF DATA POINTS: ?10

THERE ARE TWO INPUT OPTIONS. ONE (1) INPUTS THE DATA POINTS IN COORDINATE PAIRS, AND THE OTHER (2) ALLOWS ONE TO FIRST INPUT THE INDEPENDENT VARIABLE VALUES, LATER FOLLOWED BY THE DEPENDENT WHICH MODE DO YOU DESIRE? (1 OR 2): ?1

1?0,-1
2?1,2
3?2,1
4?3,4
5?4,3
6?5,6
7?6,5
8?7,8
9?8,7
10?9,10

FITTED EQUATION IS:

Y= -.2727 + 1.0606*X + .0000*X*X

STANDARD DEVIATION OF FIT: 1.0380

READY

Poole-Borchers regression is (when run on North Star BASIC, Release 2, Version 3):

$$y = 0.34545452 + 0.8015152x + 0.02727268x^2 \quad (6)$$

These coefficients have some interesting repeating number sequences, but that is not a good reason to condemn them. However, using the above regression equation and calculating the standard deviation between the fit predictions and the input data gives a standard deviation of 1.0869, as compared with a value of 1.0380 obtained using the Cramer's Rule algorithm shown in listing 1.

It is apparent that the program given in this article provides a better fit than that of Poole and Borchers. The discrepancy is probably due to the errors which occur when the square is evaluated using $x \wedge 2$ (as in Boolean-Borchers algorithm) instead of $x * x$, which is more accurate.

It is also interesting to note that although the two sets of coefficients obtained from the two different algorithms are quite disparate, the fits (as measured by the standard deviation) are similar. When data is very noisy, a range of equations may fit the data to similar precision; the polynomial coefficients obtained should not be treated as significant to very many decimal places.

<p>X= 0</p> <table border="0"> <thead> <tr> <th>Y</th> <th>Z</th> </tr> </thead> <tbody> <tr><td>.0000</td><td>-1.8770</td></tr> <tr><td>.1000</td><td>-1.4777</td></tr> <tr><td>.2000</td><td>-1.2124</td></tr> <tr><td>.3000</td><td>-.6021</td></tr> <tr><td>.4000</td><td>-.1597</td></tr> <tr><td>.5000</td><td>.6029</td></tr> <tr><td>.6000</td><td>1.4153</td></tr> <tr><td>.7000</td><td>2.1712</td></tr> <tr><td>.8000</td><td>3.0442</td></tr> <tr><td>.9000</td><td>4.0435</td></tr> <tr><td>1.0000</td><td>5.0899</td></tr> </tbody> </table>	Y	Z	.0000	-1.8770	.1000	-1.4777	.2000	-1.2124	.3000	-.6021	.4000	-.1597	.5000	.6029	.6000	1.4153	.7000	2.1712	.8000	3.0442	.9000	4.0435	1.0000	5.0899	<p>X= .3</p> <table border="0"> <thead> <tr> <th>Y</th> <th>Z</th> </tr> </thead> <tbody> <tr><td>.0000</td><td>-2.5664</td></tr> <tr><td>.1000</td><td>-2.2315</td></tr> <tr><td>.2000</td><td>-1.7197</td></tr> <tr><td>.3000</td><td>-1.1910</td></tr> <tr><td>.4000</td><td>-.6178</td></tr> <tr><td>.5000</td><td>-.0026</td></tr> <tr><td>.6000</td><td>.5297</td></tr> <tr><td>.7000</td><td>1.3222</td></tr> <tr><td>.8000</td><td>2.2567</td></tr> <tr><td>.9000</td><td>3.1909</td></tr> <tr><td>1.0000</td><td>4.0585</td></tr> </tbody> </table>	Y	Z	.0000	-2.5664	.1000	-2.2315	.2000	-1.7197	.3000	-1.1910	.4000	-.6178	.5000	-.0026	.6000	.5297	.7000	1.3222	.8000	2.2567	.9000	3.1909	1.0000	4.0585	<p>X= .6</p> <table border="0"> <thead> <tr> <th>Y</th> <th>Z</th> </tr> </thead> <tbody> <tr><td>.0000</td><td>-3.1383</td></tr> <tr><td>.1000</td><td>-2.8093</td></tr> <tr><td>.2000</td><td>-2.2651</td></tr> <tr><td>.3000</td><td>-1.8521</td></tr> <tr><td>.4000</td><td>-1.1915</td></tr> <tr><td>.5000</td><td>-.4113</td></tr> <tr><td>.6000</td><td>.3657</td></tr> <tr><td>.7000</td><td>1.0686</td></tr> <tr><td>.8000</td><td>2.1812</td></tr> <tr><td>.9000</td><td>3.0908</td></tr> <tr><td>1.0000</td><td>4.3529</td></tr> </tbody> </table>	Y	Z	.0000	-3.1383	.1000	-2.8093	.2000	-2.2651	.3000	-1.8521	.4000	-1.1915	.5000	-.4113	.6000	.3657	.7000	1.0686	.8000	2.1812	.9000	3.0908	1.0000	4.3529	<p>X= .9</p> <table border="0"> <thead> <tr> <th>Y</th> <th>Z</th> </tr> </thead> <tbody> <tr><td>.0000</td><td>-3.7272</td></tr> <tr><td>.1000</td><td>-3.3490</td></tr> <tr><td>.2000</td><td>-2.8361</td></tr> <tr><td>.3000</td><td>-2.3384</td></tr> <tr><td>.4000</td><td>-1.5902</td></tr> <tr><td>.5000</td><td>-.7453</td></tr> <tr><td>.6000</td><td>.2876</td></tr> <tr><td>.7000</td><td>1.4160</td></tr> <tr><td>.8000</td><td>2.6644</td></tr> <tr><td>.9000</td><td>3.9098</td></tr> <tr><td>1.0000</td><td>5.4958</td></tr> </tbody> </table>	Y	Z	.0000	-3.7272	.1000	-3.3490	.2000	-2.8361	.3000	-2.3384	.4000	-1.5902	.5000	-.7453	.6000	.2876	.7000	1.4160	.8000	2.6644	.9000	3.9098	1.0000	5.4958
Y	Z																																																																																																		
.0000	-1.8770																																																																																																		
.1000	-1.4777																																																																																																		
.2000	-1.2124																																																																																																		
.3000	-.6021																																																																																																		
.4000	-.1597																																																																																																		
.5000	.6029																																																																																																		
.6000	1.4153																																																																																																		
.7000	2.1712																																																																																																		
.8000	3.0442																																																																																																		
.9000	4.0435																																																																																																		
1.0000	5.0899																																																																																																		
Y	Z																																																																																																		
.0000	-2.5664																																																																																																		
.1000	-2.2315																																																																																																		
.2000	-1.7197																																																																																																		
.3000	-1.1910																																																																																																		
.4000	-.6178																																																																																																		
.5000	-.0026																																																																																																		
.6000	.5297																																																																																																		
.7000	1.3222																																																																																																		
.8000	2.2567																																																																																																		
.9000	3.1909																																																																																																		
1.0000	4.0585																																																																																																		
Y	Z																																																																																																		
.0000	-3.1383																																																																																																		
.1000	-2.8093																																																																																																		
.2000	-2.2651																																																																																																		
.3000	-1.8521																																																																																																		
.4000	-1.1915																																																																																																		
.5000	-.4113																																																																																																		
.6000	.3657																																																																																																		
.7000	1.0686																																																																																																		
.8000	2.1812																																																																																																		
.9000	3.0908																																																																																																		
1.0000	4.3529																																																																																																		
Y	Z																																																																																																		
.0000	-3.7272																																																																																																		
.1000	-3.3490																																																																																																		
.2000	-2.8361																																																																																																		
.3000	-2.3384																																																																																																		
.4000	-1.5902																																																																																																		
.5000	-.7453																																																																																																		
.6000	.2876																																																																																																		
.7000	1.4160																																																																																																		
.8000	2.6644																																																																																																		
.9000	3.9098																																																																																																		
1.0000	5.4958																																																																																																		
<p>X= .1</p> <table border="0"> <thead> <tr> <th>Y</th> <th>Z</th> </tr> </thead> <tbody> <tr><td>.0000</td><td>-2.1727</td></tr> <tr><td>.1000</td><td>-1.6902</td></tr> <tr><td>.2000</td><td>-1.3769</td></tr> <tr><td>.3000</td><td>-.7970</td></tr> <tr><td>.4000</td><td>-.3682</td></tr> <tr><td>.5000</td><td>.3858</td></tr> <tr><td>.6000</td><td>.9656</td></tr> <tr><td>.7000</td><td>1.8338</td></tr> <tr><td>.8000</td><td>2.6107</td></tr> <tr><td>.9000</td><td>3.7345</td></tr> <tr><td>1.0000</td><td>4.6834</td></tr> </tbody> </table>	Y	Z	.0000	-2.1727	.1000	-1.6902	.2000	-1.3769	.3000	-.7970	.4000	-.3682	.5000	.3858	.6000	.9656	.7000	1.8338	.8000	2.6107	.9000	3.7345	1.0000	4.6834	<p>X= .4</p> <table border="0"> <thead> <tr> <th>Y</th> <th>Z</th> </tr> </thead> <tbody> <tr><td>.0000</td><td>-2.6813</td></tr> <tr><td>.1000</td><td>-2.4391</td></tr> <tr><td>.2000</td><td>-2.0129</td></tr> <tr><td>.3000</td><td>-1.3930</td></tr> <tr><td>.4000</td><td>-.8603</td></tr> <tr><td>.5000</td><td>-.3129</td></tr> <tr><td>.6000</td><td>.5422</td></tr> <tr><td>.7000</td><td>1.2312</td></tr> <tr><td>.8000</td><td>2.0625</td></tr> <tr><td>.9000</td><td>3.0280</td></tr> <tr><td>1.0000</td><td>4.0109</td></tr> </tbody> </table>	Y	Z	.0000	-2.6813	.1000	-2.4391	.2000	-2.0129	.3000	-1.3930	.4000	-.8603	.5000	-.3129	.6000	.5422	.7000	1.2312	.8000	2.0625	.9000	3.0280	1.0000	4.0109	<p>X= .7</p> <table border="0"> <thead> <tr> <th>Y</th> <th>Z</th> </tr> </thead> <tbody> <tr><td>.0000</td><td>-3.3040</td></tr> <tr><td>.1000</td><td>-2.8519</td></tr> <tr><td>.2000</td><td>-2.4128</td></tr> <tr><td>.3000</td><td>-1.8814</td></tr> <tr><td>.4000</td><td>-1.2392</td></tr> <tr><td>.5000</td><td>-.5648</td></tr> <tr><td>.6000</td><td>.2919</td></tr> <tr><td>.7000</td><td>1.0987</td></tr> <tr><td>.8000</td><td>2.1666</td></tr> <tr><td>.9000</td><td>3.3581</td></tr> <tr><td>1.0000</td><td>4.5745</td></tr> </tbody> </table>	Y	Z	.0000	-3.3040	.1000	-2.8519	.2000	-2.4128	.3000	-1.8814	.4000	-1.2392	.5000	-.5648	.6000	.2919	.7000	1.0987	.8000	2.1666	.9000	3.3581	1.0000	4.5745	<p>X= 1</p> <table border="0"> <thead> <tr> <th>Y</th> <th>Z</th> </tr> </thead> <tbody> <tr><td>.0000</td><td>-3.8650</td></tr> <tr><td>.1000</td><td>-3.5359</td></tr> <tr><td>.2000</td><td>-3.0804</td></tr> <tr><td>.3000</td><td>-2.4238</td></tr> <tr><td>.4000</td><td>-1.5126</td></tr> <tr><td>.5000</td><td>-.5842</td></tr> <tr><td>.6000</td><td>.3587</td></tr> <tr><td>.7000</td><td>1.7134</td></tr> <tr><td>.8000</td><td>3.0229</td></tr> <tr><td>.9000</td><td>4.4793</td></tr> <tr><td>1.0000</td><td>6.0015</td></tr> </tbody> </table> <p>READY</p>	Y	Z	.0000	-3.8650	.1000	-3.5359	.2000	-3.0804	.3000	-2.4238	.4000	-1.5126	.5000	-.5842	.6000	.3587	.7000	1.7134	.8000	3.0229	.9000	4.4793	1.0000	6.0015
Y	Z																																																																																																		
.0000	-2.1727																																																																																																		
.1000	-1.6902																																																																																																		
.2000	-1.3769																																																																																																		
.3000	-.7970																																																																																																		
.4000	-.3682																																																																																																		
.5000	.3858																																																																																																		
.6000	.9656																																																																																																		
.7000	1.8338																																																																																																		
.8000	2.6107																																																																																																		
.9000	3.7345																																																																																																		
1.0000	4.6834																																																																																																		
Y	Z																																																																																																		
.0000	-2.6813																																																																																																		
.1000	-2.4391																																																																																																		
.2000	-2.0129																																																																																																		
.3000	-1.3930																																																																																																		
.4000	-.8603																																																																																																		
.5000	-.3129																																																																																																		
.6000	.5422																																																																																																		
.7000	1.2312																																																																																																		
.8000	2.0625																																																																																																		
.9000	3.0280																																																																																																		
1.0000	4.0109																																																																																																		
Y	Z																																																																																																		
.0000	-3.3040																																																																																																		
.1000	-2.8519																																																																																																		
.2000	-2.4128																																																																																																		
.3000	-1.8814																																																																																																		
.4000	-1.2392																																																																																																		
.5000	-.5648																																																																																																		
.6000	.2919																																																																																																		
.7000	1.0987																																																																																																		
.8000	2.1666																																																																																																		
.9000	3.3581																																																																																																		
1.0000	4.5745																																																																																																		
Y	Z																																																																																																		
.0000	-3.8650																																																																																																		
.1000	-3.5359																																																																																																		
.2000	-3.0804																																																																																																		
.3000	-2.4238																																																																																																		
.4000	-1.5126																																																																																																		
.5000	-.5842																																																																																																		
.6000	.3587																																																																																																		
.7000	1.7134																																																																																																		
.8000	3.0229																																																																																																		
.9000	4.4793																																																																																																		
1.0000	6.0015																																																																																																		
<p>X= .2</p> <table border="0"> <thead> <tr> <th>Y</th> <th>Z</th> </tr> </thead> <tbody> <tr><td>.0000</td><td>-2.2148</td></tr> <tr><td>.1000</td><td>-1.9373</td></tr> <tr><td>.2000</td><td>-1.5422</td></tr> <tr><td>.3000</td><td>-1.0575</td></tr> <tr><td>.4000</td><td>-.4524</td></tr> <tr><td>.5000</td><td>.1243</td></tr> <tr><td>.6000</td><td>.8916</td></tr> <tr><td>.7000</td><td>1.6626</td></tr> <tr><td>.8000</td><td>2.3359</td></tr> <tr><td>.9000</td><td>3.2565</td></tr> <tr><td>1.0000</td><td>4.3737</td></tr> </tbody> </table>	Y	Z	.0000	-2.2148	.1000	-1.9373	.2000	-1.5422	.3000	-1.0575	.4000	-.4524	.5000	.1243	.6000	.8916	.7000	1.6626	.8000	2.3359	.9000	3.2565	1.0000	4.3737	<p>X= .5</p> <table border="0"> <thead> <tr> <th>Y</th> <th>Z</th> </tr> </thead> <tbody> <tr><td>.0000</td><td>-2.9732</td></tr> <tr><td>.1000</td><td>-2.5161</td></tr> <tr><td>.2000</td><td>-2.2357</td></tr> <tr><td>.3000</td><td>-1.5418</td></tr> <tr><td>.4000</td><td>-1.0049</td></tr> <tr><td>.5000</td><td>-.4632</td></tr> <tr><td>.6000</td><td>.3524</td></tr> <tr><td>.7000</td><td>1.1281</td></tr> <tr><td>.8000</td><td>2.0464</td></tr> <tr><td>.9000</td><td>2.9854</td></tr> <tr><td>1.0000</td><td>4.0366</td></tr> </tbody> </table>	Y	Z	.0000	-2.9732	.1000	-2.5161	.2000	-2.2357	.3000	-1.5418	.4000	-1.0049	.5000	-.4632	.6000	.3524	.7000	1.1281	.8000	2.0464	.9000	2.9854	1.0000	4.0366	<p>X= .8</p> <table border="0"> <thead> <tr> <th>Y</th> <th>Z</th> </tr> </thead> <tbody> <tr><td>.0000</td><td>-3.5062</td></tr> <tr><td>.1000</td><td>-3.0467</td></tr> <tr><td>.2000</td><td>-2.6141</td></tr> <tr><td>.3000</td><td>-2.1694</td></tr> <tr><td>.4000</td><td>-1.5072</td></tr> <tr><td>.5000</td><td>-.6622</td></tr> <tr><td>.6000</td><td>.3193</td></tr> <tr><td>.7000</td><td>1.3245</td></tr> <tr><td>.8000</td><td>2.4790</td></tr> <tr><td>.9000</td><td>3.5361</td></tr> <tr><td>1.0000</td><td>4.8953</td></tr> </tbody> </table>	Y	Z	.0000	-3.5062	.1000	-3.0467	.2000	-2.6141	.3000	-2.1694	.4000	-1.5072	.5000	-.6622	.6000	.3193	.7000	1.3245	.8000	2.4790	.9000	3.5361	1.0000	4.8953																									
Y	Z																																																																																																		
.0000	-2.2148																																																																																																		
.1000	-1.9373																																																																																																		
.2000	-1.5422																																																																																																		
.3000	-1.0575																																																																																																		
.4000	-.4524																																																																																																		
.5000	.1243																																																																																																		
.6000	.8916																																																																																																		
.7000	1.6626																																																																																																		
.8000	2.3359																																																																																																		
.9000	3.2565																																																																																																		
1.0000	4.3737																																																																																																		
Y	Z																																																																																																		
.0000	-2.9732																																																																																																		
.1000	-2.5161																																																																																																		
.2000	-2.2357																																																																																																		
.3000	-1.5418																																																																																																		
.4000	-1.0049																																																																																																		
.5000	-.4632																																																																																																		
.6000	.3524																																																																																																		
.7000	1.1281																																																																																																		
.8000	2.0464																																																																																																		
.9000	2.9854																																																																																																		
1.0000	4.0366																																																																																																		
Y	Z																																																																																																		
.0000	-3.5062																																																																																																		
.1000	-3.0467																																																																																																		
.2000	-2.6141																																																																																																		
.3000	-2.1694																																																																																																		
.4000	-1.5072																																																																																																		
.5000	-.6622																																																																																																		
.6000	.3193																																																																																																		
.7000	1.3245																																																																																																		
.8000	2.4790																																																																																																		
.9000	3.5361																																																																																																		
1.0000	4.8953																																																																																																		

Listing 3: Two-dimensional data set containing noise. This set was created in a well-defined way such that the fit obtained could be compared against the original function.

SPECIAL DELIVERY

CENTRONICS MODEL 730 MINIPRINTER

A totally new printer has arrived. It delivers some special advantages to small business and home computer systems. New, expanded paper-handling capabilities. Excellent print quality and long-run reliability. All these high quality features at an affordable price is indeed *special delivery*.

3-in-1 Paper Handling Model 730's exclusive three-in-one paper handling system gives you built-in flexibility. Payroll checks on pre-printed continuous forms. Inventory listings on fanfold. Direct mail on cut sheets. General information on roll paper. The 730 does it all.

Exceptional Print Quality Model 730's 7 x 7 dot matrix prints clear, legible characters — even when printing multiple copies. The adjustable print head utilizes the same free-flight technology as Centronics' 700 Series — the most

successful line of dot matrix printers in the world — to give you longer head life and smoother operation.

Outstanding Reliability The simplicity of the Model 730's design employs fewer parts for higher reliability and less maintenance. You get more in-service time for your money.

Compact Design Model 730 packs all this performance capability into a stylish unit that can fit right on your desktop. It's no larger than a portable typewriter and weighs less than 10 pounds.

For all its features, Model 730 is priced within the budget of even the most cost-conscious systems owner. For more information on the Model

730, other products or employment opportunities, write or call today: Centronics Data Computer Corporation, Hudson, NH 03051, (603) 883-0111.



CENTRONICS PRINTERS DELIVER THE WORD

TRS-80 BUSINESS PROGRAMS

So good, they're guaranteed!!!

These are the best . . . & we're willing to back them up with our software guarantee! *
Created by Data Access' professional staff, our programs are versatile, comprehensive,
AND easy to use.

Using BASIC and ASSEMBLER, they're fast ready to "RUN". They are powerful tools that
can expedite clerical tasks, and expand management reporting.

All programs:

- + Have Data Base Management System
- + Use ISAM or Hash Access Techniques
- + Give Instant Record Retrieval
- + Have Interactive Screen Displays
- + Use Error Trapping Entry Procedures
- + Include Thorough Documentation
- + Provide Comprehensive Reporting
- + Utilize Fast Assembler Routines
- + Run under DOS 2.2
- + Include Complete Support
- + Run On 2, 3, or 4 Disk Drives

On-Line Inventory	\$600
Up to 1800 Items on 4 Drives. Distributor/Jobber orientation. Includes invoice printing!	
Point of Sale w/Inventory Control	\$750
Complete retail inventory management system. On the Screen: builds sales ticket, price items, checks for sale prices and qty's, interactive low stock alerts, allows price & qty changes (w/audit), Cash, Check, 6 Credit Cards or Company Charge, & Reporting: Daily Ticket Journal, Inventory Transaction Journal, Salesman's Report, Stock Status, Profit, & Low Stock Reports. MORE!	
Accounts Receivable	\$500
Up to 1200 accounts on 4 Drives. Full Trial Balance, Aging, Credit Checking, Monthly Statements. Also prints mailing labels for accounts!	
General Ledger w/Check Writer	\$500
Prints Checks in Cash Disbursements JLI! 600 Accounts & 2100 Transactions/Month on 3 Drives; 300/900 on 2! Supports multiple cost/profit centers, user has complete control of formatting. Prints Balance Sheet, Income Statement (P&L), Ledgers, Journals, Transaction Reports, Posting Reports . . . A Total General Ledger System!	
Payroll	\$500
Up to 600 employees on 4 Drives! Handles Federal, State, Tips, Dues & Deductions. Complete user control of all payroll functions. Prints on the same check as the General Ledger!	
Mailing List	\$200
Up to 1800 Names on 4 Drives! Six character alphanumeric key & 4 character select code for each record. Sort by key, name, state or ZIP code!	
MANUALS ONLY	\$20 each
WRITING YOUR OWN?????	
Save Days, Weeks, Months with Data Access' proven utility packages. On diskette . . .	
Memory Sort	\$39
Speed operation of BASIC programs! VERY FAST in memory assembler sort. Supplied pre-linked to load at any 4K boundary through 48K.	
Disk Sort Routines	\$79
Make the most of disk capacity & speed! Reads random data from disk, performs FAST assembler sort, and returns alphanumerically sorted list ready to pass to other program operations in BASIC. Reads & sorts 1000 records in less than 5 Minutes! Sorts as many records as can be contained on your disks!	
Data Base Manage w/ISAM	\$175
Complete database handling system! ISAM directory; interactive record create, delete, edit, display and print; file compress and backup; routines for loading assembler programs from BASIC; disk sort; INKEY data entry subroutines; random and sequential access to any record. Interactive data base specification. All source included!	

**Data Access Corporation guarantees that its programs will load & run,
and that they are free from programming defects.
A licensing agreement is required for each installation of the above programs.*

DEALER INQUIRES INVITED

Call for the name of the dealer in your area, or order direct from:

DATA ACCESS CORPORATION

11205 SOUTH DIXIE HIGHWAY
MIAMI, FLORIDA 33156
(305) 238-7919

*TRS-80 is a trademark of Radio Shack.

This is one of the dangers in curve fitting and placing great value on the results, especially when mathematically exact algorithms can be waylaid by calculation error.

In the next section we will consider how to use the one-dimensional least squares routine for fits in many dimensions.

Parabolic Fits in Many Dimensions

To examine how the one-dimensional least squares routine may be used (in approximation) in many dimensions, we will first consider the two-dimensional case.

Let x_i and y_i be the independent variables, and z_i be the dependent variable. The parabolic fit desired is:

$$z_i = f(x_i, y_i) = b_0(x_i) + b_1(x_i)y_i + b_2(x_i)y_i^2 \quad (7)$$

where:

$$b_0 = a_{00} + a_{10}x_i + a_{20}x_i^2 \quad (8a)$$

$$b_1 = a_{01} + a_{11}x_i + a_{21}x_i^2 \quad (8b)$$

$$b_2 = a_{02} + a_{12}x_i + a_{22}x_i^2 \quad (8c)$$

Ideally we would choose the nine a_{qm} coefficient values such that

$$\sum_{i=0}^{I-1} \{z_i - f(x_i, y_i)\}^2$$

is minimized. In other words, we wish to minimize the sums of the squares of the distances between predicted and actual data points. However, if the data is arranged in a tabular form, such as shown in listing 3, a quasi-least squares fit can be obtained one dimension at a time.

The way this is done is that for each x_i we regress z_i (the dependent variable) against y_i (the independent variable) to obtain a least squares set of $b_0(x_i)$, $b_1(x_i)$ and $b_2(x_i)$. Next, we treat $b_0(x_i)$ as a dependent variable and regress against x_i (the remaining independent variable) to get a_{00} , a_{01} and a_{02} . The same is done for $b_1(x_i)$ and $b_2(x_i)$.

For the data shown in listing 3, the first regression step yields the $b_q(x_i)$ values given in table 1. Each coefficient column in table 1 is then regressed against x_i to give the nine coefficients listed in table 2. These coefficients may be used with equations (8a), (8b) and (8c) to obtain the regression indicated by equation (7).

Let your LSI-11* break the 28K barrier



With our Bank-Switching family

In LOCAL mode our memory is functionally just like DEC memory. But when you run out of memory space you're not lost. Add an inexpensive Bank-Switch Controller (BSC-256) and you can go to **two megabytes**. Add another and go to **four megabytes**.

So don't get boxed in with other brands of LSI-11* memory. Break free. Join the family:

RMA-032	32K by 16 bit RAM. On-board refresh	\$1200 (Single qty.)
RMS-016	16K by 16 bit ROM. (Intel 2716)	\$300 (Single qty.)
BSC-256	The Bank-Switch Controller	\$300 (Single qty.)

Substantial quantity discounts are available. For a free copy of our Bank-Switching manual, call or write on your company letterhead.

*Digital Pathways Inc.
4151 Middlefield Road
Palo Alto, CA 94306
(415) 493-5544*

**Registered trademark of Digital Equipment Corporation*



DIGITAL PATHWAYS

Because we did the regression in two steps, the least squares criteria taken as a whole haven't been satisfied. Thus the coefficients obtained are not optimal, as will be seen shortly.

It should be noted in passing that the blocks of data (for each x_i) are equal in length. This is not a requirement for validity of the technique. What is necessary is that there be at least three independent data points in each x_i block. Otherwise D in equation (5d) becomes 0, and a divide error will result. Also observe that the x_i and y_i increments need not be equal or uniform. Few restrictions are placed on the data.

The precision of the regression fit may be assessed using the standard deviation associated with the difference between the predicted data values and the actual data. This gives 0.23, or roughly 3 percent accuracy, which is encouraging.

The equation used to generate the noisy two-dimensional data was:

$$z = 6x^2y^2 - 3xy^2 + 4y^2 - 2x + 3y - 1.9 + 0.2(RND(0)-0.5) \quad (9)$$

The standard deviation of the noise term is 0.06. Thus the 2 step fitting procedure is not as good as it could possibly be; 1 percent accuracy could be obtained using the non-random part of equation (9); a better fit.

It is left to the reader to relate the coefficients shown in table 2 to their corresponding elements in equation (9). Observe that the coefficients correspond, but with differences often greater than that indicated by the standard deviation.

Extension of the method of stepping through the regression, one dimension at a time, is simple. It is done by creating a hierarchy of "data" tables. For a three-dimensional problem involving the regression of $U = U(x, y, z)$, tables would be created in which x and y are temporarily held constant, and z varied. The three first level coefficients would then be functions of x and y . Next, tables of those three coefficients would be compiled in which x is held constant and y varied. This would lead to nine coefficients, each being a function of x . The third level regression would be against x and give 27 coefficients.

I have had opportunity in the past to apply this technique to a horrendous engineering measurement problem involving five independent variables (several thousand measured data points). Four of the dimensions were parabolically fitted, one was approximated using a fourth order polynomial. (Note that there is a freedom in the form of the fitting function applied in each dimension.) In this application, the data was regenerated to a standard deviation of better than 3 percent, which was more than sufficient. Although the fit was not optimal, the savings in programming time and sanity more than compensated for whatever error occurred.

x_i	$b_0(x_i)$	$b_1(x_i)$	$b_2(x_i)$	Standard Deviation
0.0	-1.8758	2.9021	4.0807	0.05
0.1	-2.2677	3.1672	4.2439	0.24
0.2	-2.4542	3.2702	3.9614	0.24
0.3	-2.7791	3.7056	3.5807	0.24
0.4	-2.9875	3.5408	3.8676	0.23
0.5	-3.2118	3.5623	4.0746	0.23
0.6	-3.4316	3.5360	4.5941	0.24
0.7	-3.5456	3.2876	5.2208	0.25
0.8	-3.8010	3.3066	5.8698	0.27
0.9	-4.0544	3.1017	6.9178	0.28
1.0	-4.2911	3.4786	7.4185	0.31

Table 1: First level regression coefficients.

a_{qm}	q	0	1	2	Standard Deviation
m	0	-1.9433	-2.7209	0.4263	0.05
	1	3.0110	1.8648	-1.6931	0.17
	2	4.2540	-3.6091	6.9833	0.18

Table 2: Nine regressed coefficients corresponding to equations 8a, 8b, and 8c in text.

Conclusions

The multidimensional curve fitting technique presented in this article depends only on the existence of a good one-dimensional least squares routine. The form of the least squares fitting function can be different for each dimension regressed. Often the form can be chosen by either an understanding of the causal relationships, or by simply scanning the data.

The user who has some familiarity with algebra and calculus can generate a least squares fit for other functional forms using the simultaneous equation technique shown herein. Recall that the equations were obtained by considering the error to be a function of the coefficients, and partial derivatives were taken with respect to each coefficient.

In conclusion, this article presents a general technique for generating one-dimensional least squares fitting algorithms, and shows how such algorithms may be used to regress multidimensional data. ■

Build your own microcomputer as you learn computer technology at home.

New from NRI! The Most Complete and Up-to-date Home Study Course Ever Offered

As the microprocessor revolutionizes the computer world and microcomputers appear almost everywhere, NRI brings you a new, convenient, and effective way to keep up with this expanding technology. It's NRI's Computer Technology Course, created and designed exclusively for learning at home in your spare time.

Featuring NRI's Exclusive Dual Language Microcomputer

NRI goes beyond book learning to give you practical, "hands-on" experience in designing circuitry, interfacing components, programming, and troubleshooting. As you learn, you actually assemble NRI's designed-for-learning microcomputer, incorporating the latest advances in the state of the art. It looks and operates like the finest of its kind, actually does more than many commercial units. But NRI engineers have designed components and planned assembly so it demonstrates important principles, gives you working experience in detecting and correcting problems. And it's yours to keep, put to work in your own home or business.

You also build and keep your own test instruments, including a transistorized volt-ohm meter and CMOS digital frequency counter. And NRI's Discovery Lab[®] broadens your horizons with specialized experiments and theory demonstrations.

The Proven Way to Learn at Home

You don't have to worry with travel, classes, or time lost from work when you learn the NRI way. As they have for more than 60

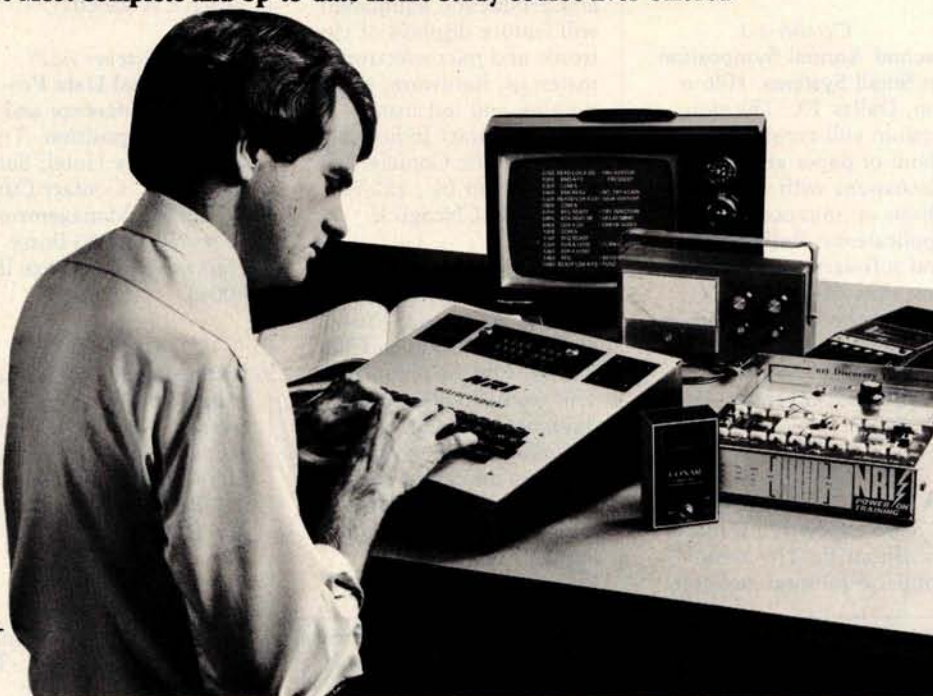

years of teaching technical subjects, NRI brings the material to you. You study in your spare time, at your convenience, using "bite-size" lessons that program material into logical segments for easier assimilation. You perform experiments and build equipment using kits we supply. And your personal NRI instructor is always available for consultation should you have questions or problems. Over a million students have already shown the effectiveness of NRI training.

Choice of Courses

Several courses are available, depending upon your needs and background. NRI's Master Course in Computer Technology starts with the fundamentals, explores basic electronics and digital theory, the total computer world, and the microcomputer. The Advanced Course, for students already versed in electronics and general computers, concentrates on the microprocessor and microcomputer. In both courses, you build all instruments and your own computer.

Send for Free Catalog... No Salesman Will Call

Get the details on these exciting new courses in NRI's free, 100-page catalog. Shows all kits and equipment, lesson outlines, and full information, including facts on other electronics courses. Mail the coupon today and we'll rush your catalog. No salesman will ever call. Keep up with the latest technology as you learn on your own computer. If coupon has been removed, write to NRI Schools, Computer Department, 3939 Wisconsin Ave., Washington, D.C. 20016.



NRI Schools
McGraw-Hill Continuing
Education Center
3939 Wisconsin Avenue
Washington, D.C. 20016

NO SALESMAN WILL CALL
Please check for one free catalog only.

- Computer Electronics Including Microcomputers
- TV/Audio/Video Systems Servicing
- Complete Communications Electronics with CB • FCC Licenses • Aircraft, Mobile, Marine Electronics
- CB Specialists Course
- Amateur Radio • Basic and Advanced



All career courses approved under GI Bill.
 Check for details.

- Digital Electronics • Electronic Technology • Basic Electronics
- Small Engine Repair
- Electrical Appliance Servicing
- Automotive Mechanics
- Auto Air Conditioning
- Air Conditioning, Refrigeration, & Heating Including Solar Technology

Name _____ (Please Print) Age _____

Street _____

City/State/Zip _____

Accredited by the Accrediting Commission of the National Home Study Council **170-109**

Event Queue

OCTOBER 1979

October 1-3

Second Annual Symposium on Small Systems, Hilton Inn, Dallas TX. The symposium will consist of a blend of paper and panel discussions with major emphasis on microcomputer applications. Both hardware and software topics presenting state-of-the-art and state-of-the-industry aspects will be included. Contact Gerald Kane, Southern Methodist University, Dallas TX 75222.

October 2-4

NEPCON Central '79, O'Hare Exposition Center, Rosemont IL. This tenth annual exhibition and con-

ference of electronic and microelectronic packaging and production equipment will feature displays of electronic and microelectronic materials, hardware, tools, supplies and test instruments. Contact Industrial and Scientific Conference Management Inc, 222 W Adams St, Chicago IL 60606.

October 6

Personal Computer Music Festival, Philadelphia Civic Center, Philadelphia PA. This festival will feature a daytime exhibition and fair including demonstrations; seminars and guest speakers; evening concert; and multimedia show. Contact PACS, POB 1954, Philadelphia PA 19105.

October 10

Invitational Computer Conference, Newton MA. This conference is directed to the quantity buyer, and will feature the newest developments in computer and peripheral technology. Contact B J Johnson and Associates, 2503 Eastbluff Dr, Suite 203, Newport Beach CA 92660.

October 14-17

International Data Processing Conference and Business Exposition, Town and Country Hotel, San Diego CA. Contact Data Processing Management Association, 505 Busse Highway, Park Ridge IL 60068.

October 15-18

Sixth Information Management Exposition and Conference, New York Coliseum, New York NY. Contact Clapp and Poliak Inc, 245 Park Ave, New York NY 10017.

October 15-19

Distributed Processing, George Washington University, Washington DC. This course is designed for engineers, computer scientists and data processing managers who need a better working knowledge of distributed processing techniques as applied to complex computing problems. Contact Continuing Engineering Education, George Washington University, Washington DC 20052.

October 15-19

CPEUG 79, San Diego CA. This is the fifteenth meeting of the Computer Performance Evaluation Users Group sponsored by the National Bureau of Standards. Contact Judith G Abilock, The MITRE Corp, Metrek Division, 1820 Dolley Madison Blvd, McLean VA 22102.

October 16-18

Understanding and Using Computer Graphics, Washington DC. This course is for people who are now using, or making decisions about using computer

graphics and its role in their organization. It will describe computer graphics, explain what hardware and software systems are available and give cost and performance comparisons. Contact Frost and Sullivan, 106 Fulton St, New York NY 10038.

October 17-18

The Western Computer Conference, The Calgary Convention Centre, Calgary, Alberta. Some of the session topics to be discussed are distributed data processing in the natural resources industries; growth of the original equipment manufacturers (OEM) market in Canada's western provinces; transborder data flows, national and international; and use of graphics in seismicographic and geophysical modeling. Contact Janet Glover, Conference Co-ordinator, Whitest Publishing Ltd, 2 Bloor St W, Suite 2504, Toronto, Ontario CANADA M4W 3E2.

October 20-21

Fourth Annual Tidewater Hamfest-Computer Show-Flea Market, Cultural and Convention Center, Norfolk VA. Contact TRC, POB 7101, Portsmouth VA 23707.

October 21-23

New York State Association for Educational Data Systems Annual Conference, Granit Hotel, Kerhonksen NY. The theme of this conference is Instructional Computing — Hardware/Software/Courseware. Contact Mary E Heagney, 9201 Shore Rd, Brooklyn NY 11209.

October 22-23

Minicomputer Technology, George Washington University, Washington DC. This course will cover internal operation, programming, and performance of minicomputers with examples drawn from current systems. Contact Continuing Engineering Education, George Washington University, Washington DC 20052.

VULCAN = DBMS

THE PROFESSIONAL DATABASE MANAGEMENT SYSTEM

For 8080/Z80 systems under CP/M or PTDOS

- * **VULCAN** is a complete database management system that has 38 powerful, easy to learn, English-like commands to manipulate files, records, fields, and scratch-pad variables.
- * **VULCAN** has a command repertoire which includes such commands as: SORT, REPORT, APPEND, INSERT, EDIT, COPY, REPLACE, LOCATE, DISPLAY, DO, LIST, and LOOP.
- * **VULCAN** structured data records can be selectively chosen for processing using complex Boolean, string, or mathematical expressions.
- * **VULCAN** can be used in interacter or program mode. The program mode uses modern structured command programs to combine powerful DBMS operations.
- * **VULCAN** is written in assembly language for efficient information processing and requires 36K bytes CP/M system and one or more disk drives.
- * **VULCAN** can accept or store data in standard ASCII files to be compatible with BASIC, FORTRAN, etc.

***VULCAN** (CP/M or PTDOS) \$490
Manual only \$ 25

SCDP

Software Consultation Design and Production

6542 Greeley St.

Tujunga, CA 91042 (213) 352-7701

California residents add 6% sales tax.

5-STAR EDITION
for users of
Radio Shack's TRS-80*



5-STAR EDITION
for users of
Radio Shack's TRS-80*

TRS-80 TRANSFORMED WITH PROFESSIONAL SOFTWARE PACKAGES

AND MUCH MORE

Software with Manual Alone

CP/M-operating system modified for use with TRS-80 computer and disks. In addition to the standard CP/M utilities of Editor, Assembler, Debugger etc., we have added: DCV2 (Utility to convert system tapes to CP/M files.) DISKAS & CASDISK (Utilities to back up files to tape and recover to disk.) MOVEFI (Program to transfer files with single drive systems) **\$145/\$25**

All items listed below operate in conjunction with the CPM operating system.

MAC — 8080 Macro Assembler. Full Intel macro definitions. Pseudo Ops include RPC, IRP, REPT, TITLE, PAGE, and MACLIB. Z-80 library included. Produces Intel absolute hex output plus symbols file for use by SID (see below) **\$100/\$15**

SID — 8080 symbolic debugger. Full trace, pass count and break-point program listing system with back-trace and histogram utilities. When used with MAC, provides full symbolic display of memory labels and equated values **\$85/\$15**

TEX — Text formatter to create paginated, page-numbered and justified copy from source text files. Directs to disk or printer **\$85/\$15**

DESPPOOL — Program to permit simultaneous printing of data from disk while user executes another program from the console **\$50/\$10**

Disk Extended BASIC — Version 5 ANSI compatible with long variable names, WHILE/WEND, changing variable length file records **\$300/\$25**

BASIC Compiler — Language compatible with Version 5 Microsoft interpreter and 310 memory resident execution. Produces standard Microsoft relocatable binary output. Includes Macro-80. Also linkable to FORTRAN-80 or COBOL-80 code modules **\$350/\$25**

FORTRAN-80 — ANSI 66 (except for COMPLEX) plus many extensions. Includes relocatable object compiler, linking loader, library with manager. Also includes MACRO-80 (see below) **\$400/\$25**

MACRO-80 — 8080/280 Macro Assembler. Intel and Zilog mnemonics supported. Relocatable linkable output. Loader, Library Manager and Cross Reference List utilities included **\$149/\$15**

EDIT-80 — Very fast random access text editor for text with or without line numbers. Global and intra-line commands supported. File compare utility included **\$89/\$15**

CIS COBOL (standard) — ANSI '74 COBOL standard compiler fully validated by U.S. Navy tests to ANSI level 1. Supports many features to level 2 including dynamic loading of COBOL modules and a full ISAM file facility. Also, program segmentation, interactive debug and powerful interactive extensions to support protected and unprotected CRT screen formatting from COBOL programs used with any dumb terminal **\$850/\$50**

CIS COBOL (compact) — COBOL subset compiler for use on a 32K byte microcomputer. Valuable range of COBOL language features, many at level 2 and including ISAM and the CIS COBOL interactive screen formatting of dumb terminals **\$850/\$50**

Forms 1 — CRT screen editor to build application CRT formats with protected and unprotected field areas. Output is COBOL data descriptions for copying into CIS COBOL programs. Eliminates the chore of writing screen input and output descriptions by hand and greatly speeds interactive application programming. Output requires CIS COBOL compact compiler **\$125/\$30**

Forms 2 — Forms 1 screen editor plus indexed file application program generator. Automatically creates a query and update program of indexed files using CRT protected and unprotected screen formats. No programming experience needed. Output program directly compiled by either of CIS COBOL compilers **\$200/\$30**

CBASIC-2 Disk Extended BASIC — Non-interactive BASIC with pseudo-code compiler and runtime interpreter. Supports full file control, chaining, integer and extended precision variables, etc. **\$109/\$15**

BDS C Compiler — Supports most major features of language, including Strings, Arrays, Pointers, recursive function evaluation, linkable with library to 8080 binary output. Lacks data initialization, long & float type and static & register class specifiers. Documentation includes "C Programming Language book by Kernighan & Ritchie" **\$110/\$15**

ALGOL 60 Compiler — Powerful block-structured language featuring economical run time dynamic allocation of memory. Very compact (24K total RAM) system implementing almost all Algol 60 report features plus many powerful extensions including string handling, direct disk address I/O etc. Requires Z80 CPU **\$150/\$50**

Z80 Development Package — Consists of: (1) disk line editor, with global inter and intra-line facilities; (2) Z80 relocating assembler, Zilog/MosTek mnemonics, conditional assembly and cross reference table capabilities; (3) linking loader producing absolute Intel hex disk file **\$95/\$20**

ZDT — Z80 Debugger to trace, break and examine registers with standard Zilog/MosTek mnemonic disassembly displays. Facilities similar to DOT, 535 when ordered with Z80 Development Package **\$50/\$10**

TEXTWRITER III — Text formatter to justify and paginate letters and other documents. Special features include insertion of text during execution from other disk files or console, permitting recipe documents to be created from linked fragments on other files. Has facilities for sorted index, table of contents and footnote insertions. Ideal for contracts, manuals, etc. **\$125/\$30**

Postmaster — A comprehensive package for mail list maintenance. Features include keyed record extraction and label production. A form letter program is included which provides neat letters on single sheet or continuous forms. Requires CBASIC **\$345/\$30**

SELECTOR III — Multi (i.e., up to 24) Key version of Selector II. Comes with applications programs including Sales Activity, Inventory, Payables, Receivables, Check Register, Expenses, Appointments, and Client/Patient. Requires CBASIC. Supplied in source code **\$295/\$30**

Enhanced version for CBASIC-2 **\$345/\$30**

Flippy Disk Kit — Template and instructions to modify single sided 5 1/4" diskettes for use of second side in single sided drives **\$12/\$50**

Lifeboat Associates, specialists in microcomputer disk software, is proud to offer the first professional disk-based language and utility package for the Radio Shack TRS-80 computer. Written by Microsoft, creators of Level II BASIC, the package runs on a TRS-80 system with 32K RAM, one or more drives and TRSDOS. The software is supplied on diskettes and consists of:

FORTRAN a true relocatable machine code compiler for ANSI FORTRAN X3.9 (except COMPLEX variables).

MACRO ASSEMBLER a disk-based macro assembler utilizing Zilog mnemonics and producing relocatable code.

LINKING LOADER to link-edit and load FORTRAN and assembler modules for execution.

SUBROUTINE LIBRARY a complete library of subroutines existing as relocatable linkable modules for FORTRAN or assembler programs—e.g., double precision square root, natural log, transcendentals, etc.

DISK TEXT EDITOR to create and modify FORTRAN and assembler programs as disk files; also can be used as a general purpose text editor for correspondence and other documents.

This high-powered professional software package with full documentation is available at the DISCOUNT PRICE OF **\$150.** PER COMPUTER SYSTEM

The Macro Assembler, Loader, Editor, and Cross Reference Utilities alone **\$80**

The Fortran Compiler, Loader, Editor, and extensive library of scientific functions alone **\$80**

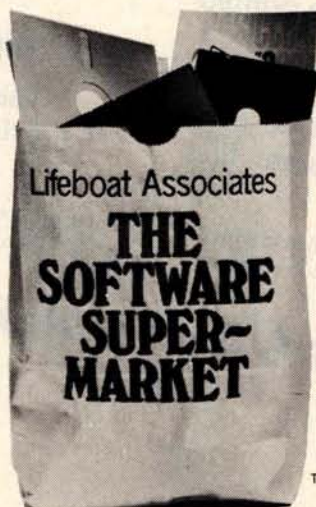

2248 Broadway, New York, N.Y. 10024
Telex: 668-585
(212) 580-0082

Lifeboat Associates
2248 Broadway
New York, N.Y. 10024 Telex: 668-585

Please send the following:

Software	Price
<input type="checkbox"/> manual alone	
<input type="checkbox"/> manual alone	
<input type="checkbox"/> Check <input type="checkbox"/> UPS C.O.D.	shipping
<input type="checkbox"/> Visa <input type="checkbox"/> MasterCard	\$1. for C.O.D.
	Total

Account # _____ Exp. Date _____

Signature _____

My computer configuration (specify disk system) _____

Name _____
Address (No P.O. Box) _____

City _____ State _____ Zip _____

G2 Level III BASIC by Microsoft
Powerful extensions to Level II BASIC including 10 machine language user calls, long error messages, keyboard debounce, graphics commands and much more. Price includes User Manual, a Quick-Reference Card and a pre programmed cassette tape **\$45**

*Radio Shack and TRS-80 are trademarks of Tandy Corporation.

October 22-24

The Association of Computer Programmers and Analysts Ninth Annual Conference, Washington DC. The general theme of this conference is Preparing Today for Tomorrow's New Technologies. Suppliers of software packages and computer services have been invited to describe and present their products in a series of structured presentations. Other sessions will cover trends in system technology and new methodologies for sharpening the professional skills of both systems analysts and programmers. Contact DBD Systems Inc, 1500 N Beauregard St, Alexandria VA 22311.

October 22-24

Computers in Aerospace Conference II, Hyatt House Hotel, Los Angeles CA. The conference theme, Computer Technology for Space and Aeronautical Systems in the Eighties, will be carried out by a series of panels, invited

presentations, and contributed papers which will bring computer system technologists together with specialists in the application of embedded computers in space and aeronautics. Contact American Institute of Aeronautics and Astronautics, 1290 Avenue of the Americas, New York NY 10019.

October 22-25

ISA/79, O'Hare Exposition Center, Chicago IL. The conference theme, Instrumentation for Energy Alternatives, will emphasize current practices in instrumentation design and implementation. Contact Instrument Society of America, 400 Stanwix St, Pittsburgh PA 15222.

October 22-26

Integrated Circuits for Signal Processing, University of Waterloo, Waterloo, Ontario, Canada. This course is designed to meet the needs of electronic

design engineers, supervisory-level engineers and technical managers who are involved in hardware-oriented programs and desire an up-to-date knowledge of modern integrated circuits for signal processing. Contact ICSP 1979, Electrical Engineering Dept, University of Waterloo, Waterloo, Ontario, CANADA W2L 3G1.

October 22-26

Pascal Programming for Mini and Microcomputers, Ramada Inn, Woburn MA. Sponsored by the Polytechnic Institute of New York and the Institute for Advanced Professional Studies, this workshop will include application examples, lectures, informal sessions with the instructor, as well as individual and group programming sessions. Contact Professor Donald D French, Institute for Advanced Professional Studies, One Gateway

Center, Newton MA 02158.

October 24-26

Design and Selection of Minicomputer Systems, George Washington University, Washington DC. The course will cover all aspects of systems implementation using microcomputers: hardware selection and configuration, software design and programming, peripheral equipment, interfacing with special equipment, and operations management. Contact Continuing Engineering Education, George Washington University, Washington DC 20052.

October 28-30

The Tenth North American Computer Chess Championship, Detroit Plaza, Detroit MI. Sponsored by the Association for Computing Machinery, this is a 4 round Swiss-style tournament with the first 2 rounds to be played on October 28th (1 PM and 7:30 PM), 1 on

WORD PROCESSING

TEXTWRITER IS THE ULTIMATE TEXT FORMATTER

For CP/m, TRS-80, Northstar & Micropolis

- **CONTRACTS & SPECIFICATIONS**

Standard paragraphs or sections stored in files and inserted by name when printed

- **BOOKS & ARTICLES**

Footnotes collected & printed at page bottom, chapters kept in separate files chained together when printed

- **PERSONALIZED FORMLETTERS**

Names, addresses, etc. replaced by entries from a mail list file or from the keyboard

- **REPORTS & MANUALS**

Table of contents & alphabetized index printed automatically

Formats files created by your editor
Available on all common 8" & 5 1/4" disks
printed manual in 3-ring binder

• Works with any terminal & printer

• Written in assembly language for high speed

• Versions for CP/m, TRS-80 CP/m, Northstar DOS and Micropolis MDOS

• Fifty page

Ask Your Dealer For A Demonstration

For Further Information Call
(415) 455-4034

Textwriter III \$125

Manual alone - \$15

Add \$2 per order for shipping

Foreign airmail \$7.50

\$1 extra UPS COD

California residents add 6 1/2% sales tax



1492 Windsor Way, Livermore, CA 94550

November 6-8

Institute of Electrical and Electronic Engineers (IEEE) Third International Conference on Computer Software and Applications, The Palmer House, Chicago IL. Contact IEEE Computer Society, POB 639, Silver Spring MD 20901.

November 6-8

Third Digital Avionics Systems Conference, Fort Worth TX. This conference will probe the expectations and challenges of the digital revolution in avionics systems. Contact John C Ruth, Technical Program Chairman, POB 12628, Fort Worth TX 76116.

November 12-14

Computer Cryptography, The George Washington University, Washington DC. The objective of this course is to provide each participant with a working knowledge of the use of cryptography in computer applications. Contact

Continuing Education, George Washington University, Washington DC. 20052.

November 14-16

International Micro and Mini Computer Conference, Astro Village, Houston TX. This conference concerns micro and mini computer systems, a survey of the range of current applications, and exploration of potential areas for future development. Emphasis will be placed on technical papers and exhibits. Contact Dr S C Lee, School of Electrical Engineering and Computer Sciences, University of Oklahoma, Norman OK 73019.

November 15

Invitational Computer Conference, Southfield MI. See October 10th for details.

November 28-30

Business and Personal Computer Sales Expo '80, Philadelphia Civic Center,

Philadelphia PA. Contact Produx 2000 Inc, Roosevelt Blvd and Mascher St, Philadelphia PA 19120.

November 29-30

Metric Management Workshop, Dallas North Park Inn, Dallas TX. The workshop is designed to help personnel at all levels plan and implement a cost-effective transition to metric in their company. The sessions will cover establishing a metric plan and strategy, assigning responsibility for the transition within the existing organizational structure, and developing a sensible approach to controlling conversion costs. Contact Len Boselovic, ANMC, 1625 Massachusetts Ave NW, Washington DC 20036.

DECEMBER 1979

December 3-5

Implementing Cryptography in Data Processing and Communications Systems, New York NY. Going beyond an introduction to cryptographic systems, the seminar will stress implementation of the data encryption system (DES) and address public key implementation considerations. Contact Ms Jansen, Cryptotech, 12 State Rd, Bellport NY 11713.

December 3-5

Winter Simulation Conference, Holiday Inn, Embarcadero, San Diego CA. This conference will feature papers and panel discussions on discrete and combined (discrete and continuous) simulations. Contact Professor Robert E Shannon, University of Alabama in Huntsville, School of Science and Engineering, POB 1247, Huntsville AL 35807.

December 3-5

COMDEX '79, MGM Grand Hotel, Las Vegas NV. This conference and exposition for third party sellers of computer systems, word processing systems,

peripherals and software packages and media will focus on solutions to business problems normally encountered in structuring a successful dealership and the operational aspects of the dealership from both the supplier and customer side. Contact The Interface Group, 160 Speen St, Framingham MA 01701.

December 10-12

Project Management for Computer Systems, Chicago IL. This seminar will illustrate techniques for planning, implementing, installing, and controlling projects. Contact The University of Chicago, 1307 E 60th St, Chicago IL 60637.

December 10-13

1979 Fall DECUS US Mini/Midi Symposium, San Diego CA. This symposium is an opportunity for Digital Equipment Computer users to participate in a technical exchange. Contact DECUS, One Iron Way, MR2-3, Marlboro MA 01752.

December 10-14

Institute of Electrical and Electronic Engineers (IEEE) Computer Society's Tutorial Week 79, Hotel Del Coronado, San Diego CA. Fifteen different 1 day seminars will be offered throughout the week. Contact IEEE Computer Society, POB 639, Silver Spring MD 20901.

In order to gain optimum coverage of your organization's computer conferences, seminars, workshops, courses, etc, notice should reach our office at least three months in advance of the date of the event. Entries should be sent to: Event Queue, BYTE Publications, 70 Main St, Peterborough NH 03458. Each month we publish the current contents of the queue for the month of the cover date and the two following calendar months. Thus a given event may appear as many as three times in this section if it is sent to us far enough in advance.

MICROTEK OUTPERFORMS SUPER BRAIN



CHECK THE CHART

SEE PAGE 19

a PERCOM SAMPLER



For your SS-50 bus computer — the CIS-30+

- Interface to data terminal and two cassette recorders with a unit only 1/10 the size of SWTP's AC-30.
- Select 30, 60, or 120 bytes per second cassette interfacing, 300, 600 or 1200 baud data terminal interfacing.
- Optional mod kits make CIS-30+ work with any microcomputer. (For MITS 680b, ask for Tech Memo TM-CIS-30+—09.)
- KC-Standard/Bi-Phase-M (double frequency) cassette data encoding. Dependable self-clocking operation.
- Ordinary functions may be accomplished with 6800 Mikbug™ monitor.
- Prices: Kit, \$79.95; Assembled, \$99.95.

Prices include a comprehensive instruction manual. Also available: Test Cassette, Remote Control Kit (for program control of recorders), IC Socket Kit, MITS 680b mod documentation, Universal Adaptor Kit (converts CIS-30+ for use with any computer).

MIKBUG® Motorola, Inc.

In the Product Development Queue . . .

Coming PDQ. Watch for announcements.

6809 Processor Card — With this SS-50 bus PC board, you'll be able to upgrade with the microprocessor that Motorola designers describe as the "best 8-bit machine so far made by humans."

The Electric Crayon™ — This color graphics system includes its own μ P and interfaces to virtually any microcomputer with a parallel I/O port.

Printer Interface — For your TRS-80™. Interface any serial RS232 printer to your TRS-80™ with this system.

™ELECTRIC WINDOW, ELECTRIC CRAYON, Pilon-30 and Pilon-10 are trademarks of Percom Data Company, Inc.
TRS-80 is a trademark of Tandy Corporation and Radio Shack which has no relationship to Percom Data Company.

Orders may be paid by check or money order, or charged to Visa or Master Charge credit account. Texas residents must add 5% sales tax.



For your data storage — Pilon-30™ and Pilon-10™ data cassettes

- Orders-of-magnitude improvement in data integrity over ordinary audio cassettes.
- Pilon-coated pressure pad eliminates lint-producing felt pad of standard audio cassettes.
- Smooth pilon coating minimizes erratic tape motion.
- Foam pad spring is energy absorbing. Superior to leaf spring mounted pad which tends to oscillate and cause flutter.
- Five-screw case design virtually precludes deformation during assembly.
- Price: \$2.49.

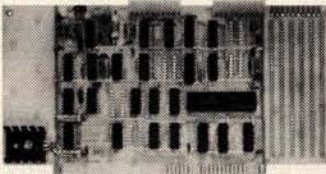

For your S-100 computer — the CI-812

- Both cassette and data terminal interfacing on one S-100 bus PC board.
- Interfaces two recorders. Record and playback circuits are independent.
- Select 30, 60, 120, or 240 bytes per second cassette interfacing, 110 to 9600 baud data terminal interfacing.
- KC-Standard/Bi-Phase-M (double frequency) encoded cassette data. Dependable self-clocking operation.
- Optional firmware (2708 EPROM) Operating System available.
- Prices: kit, \$99.95; assembled, \$129.95.

Prices include a comprehensive instruction manual. In addition to the EPROM Operating System, a Test Cassette, Remote Control Kit (for program control of recorders), and an IC Socket Kit are also available.

CASSETTE SOFTWARE

For 8080/Z-80 μ Cs . . .

BASIC ETC — Developed by the co-authors of the original Tiny BASIC, BASIC ETC is easy to use yet includes commands and functions required for powerful business and scientific programs as well as for hobby applications. 9.5K bytes of RAM. 1200-baud cassette and 42-page user's manual . . . \$35.00

Cassette Operating System — EPROM (2708) COS for the Percom CI-812 dual peripheral interfacing PC card . . . \$39.95

If you're programming on a 6800 μ C, you'll want these development and debugging programs written by Ed Smith of the Software Works:

Disassembler/Source Generator — Disassembles SWTP Resident Assembler, TSC Mnemonic Assembler/Text Editor or Smoke Signal Mnemonic Assembler/Text Editor and produces compacted source code suitable for re-editing. Prints or displays full assembly-type output listing. 4K bytes of RAM.

(Order M68SG) . . . \$25.00

Disassembler/Trace — Use to examine (or examine and execute) any area of RAM or ROM. "Software-single-step" through any program, change the contents of CPU or memory location at any time, trace subroutines to any depth. 2.3K bytes of RAM.

(Order M68DT) . . . \$20.00

EPROM Support/Relocator Program —

This program relocates a program in any contiguous area of RAM or ROM to anywhere in RAM. Use to assemble and test programs in RAM, adjust programs for EPROM operating addresses and then block move to your EPROM burner address. 952 bytes of RAM. Loads at hex 1000.

(Order M68EP) . . . \$20.00

Relocating Assembler & Linking Loader (M68AS) . . . \$50.00

Relocating Disassembler & Segmented Source Text Generator (M68RS) \$35.00

Americana Plus — 14 tunes for the Newtech Model 68 Music Board in machine language ready to load and run. Cassette compatible with Percom CIS-30+ and SWTP AC-30. Order MC-1SW . . . \$15.95

HARDWARE

Newtech Model 68 Music Board — Produces melodies, rhythms, sound effects, Morse code, etc. from your programs. Includes manual with BASIC for writing music scores and assembly language routine to play them. Installs in SWTP I/O slot. Assembled & tested . . . \$59.95

The Percom ELECTRIC WINDOW™ — Memory-resident and programmable, this video display character generator board for your SS-50 bus displays up to 24 80-character lines. Features dual character generators, dual-intensity high-lighting. One programmable register controls scrolling. Compatible with standard video monitors . . . \$249.95

SS-50 Prototype Cards:

Large card (up to 70 40-pin ICs) \$24.95
I/O size card . . . \$14.95

PERCOM

PERCOM DATA COMPANY, INC.

DEPT. B

211 N. KIRBY • GARLAND, TX. 75042

PERCOM™ 'peripherals for personal computing'

To order products or request additional literature, call Percom's toll-free number: 1-800-527-1592. For detail technical information call (214) 272-3421.

Low-Level Program Optimization:

Some Illustrative Cases

James Lewis
President
Micro Logic Corp
POB 174
Hackensack NJ 07602

.....
A program or subroutine can usually be modified so that it requires less time or space for execution.
.....

The above observation about optimization suggests that a program or subroutine can usually be changed, so that it either runs faster or takes up less memory space, and one can often accomplish both at the same time.

Programs can be optimized for other things, such as readability, maintainability, structure, etc. This article, however, stresses optimization for time and space. If a program written for a microprocessor can be made shorter using space optimization, less memory can be used, or more functions can be packed into the same memory. Either way, optimization pays off. If the program can be made to run faster, more functions can be performed in the same amount of time. In fact, optimization can make the difference between whether or not an application of a microprocessor is feasible.

A distinction can be made between 2 types of optimization techniques. One is code optimization and the other is algorithmic optimization. Code optimization involves concentrating on the structure of the actual code on a low level. This includes such operations as reordering instruc-

tion sequences and combining 2 instructions into 1 instruction. Algorithmic optimization is on a high level and involves rethinking the whole approach to a program or section of a program. This is much more general and powerful than code optimization, but its rules cannot easily be written down. It takes an experienced programmer or system designer to perform algorithmic optimization effectively. Examples of code optimization tricks will be given below.

In the event that a program cannot be modified so that both space and time are lessened, there is usually the possibility of a trade-off. That is, if space is decreased, time will increase, and if time is decreased, space will increase. Only the particular situation can determine which route to take.

How much optimization is possible? Experience has shown that upon careful analysis a first draft program can typically be reduced by as much as 50 percent or more in terms of memory space. Time optimization is another story. Some programs can be accelerated at the expense of using more memory. However, significant time reductions can usually be made

at little expense of memory; in fact, there may even be a savings of memory.

How much optimization should be done? In the process of optimizing a program, it becomes harder and harder to discover more program reductions. How far one should go depends on the relation between the cost of the programmer's time and the savings due to optimizations.

The process of optimization has fringe benefits. In analyzing a program, the programmer gains a clearer picture of how it works and often finds bugs. It is clear that a good software engineer should spend some time optimizing code.

Before discussing the techniques themselves, it should be pointed out that not all of the ideas mentioned are always beneficial. For example, one of the tricks reduces the elegance of the subroutine structure. If this type of elegance is desired, perhaps the trick should not be used.

The ideas presented are applicable to most microprocessors. They are intended for use on assembly language programs, although some of them apply to other languages. An English assembly language is used in the examples for generality. Note that the command CALL SUB means push the return address on the stack and then jump to the subroutine.

The code optimization examples will usually be presented in the following format:

About the Author

James Lewis is president of Micro Logic Corp. His company has done microprocessor applications ranging from laser-beam controllers to chemical-analyzer systems. Their development lab is in Hackensack NJ.

```

      that processor are here. Just thumb
      through the pages of this magazine.
      There are at least five different
      companies selling them. So, which one's for
      you? How do you judge the differ-
      ences? And what about cost. Are you
      willing to pay the 300 plus dollars that
      some of the companies are asking?

      Well go ahead and compare! AU-
      TOTYPE comes out ahead in EVERY
      category!

      Features? AUTOTYPE has more power-
      ful features than ANY other Word
      Processor on the market. But, don't
      take our word. Go ahead, compare!
      AUTOTYPE has an exclusive MACRO
      programming capability. No other Word
      Processor can make that claim. AU-
      TOTYPE also has a scratch Holding
      Buffer. Again, no one else even comes
      close.

      Price? AUTOTYPE beats 'em all! With
      a price tag of $195, AUTOTYPE is well
      below the competition. But, again, don't
      just take our word. Go ahead, look for
      yourself. Then fill out the order form
      below to start processing words instead
      of using a word processor!

      CAN I MOVE PARAGRAPHS
      AROUND?

      YES! AUTOTYPE has a Holding Buffer
      that can be used to save any amount of
      text and then Unhold it to the location
      you want. AUTOTYPE even allows you
      to do multiple Unholds!

      CAN I MERGE CUSTOMERS
      NAMES INTO LETTERS?

      YES! AUTOTYPE contains a "merge"
      character that may be placed any-
      where in text. Then, at the time text is
      printed, a separate file may be merged
      into the letter and then printed! An-
      other feature that NO OTHER WORD
      PROCESSOR has!

      CAN I ENTER TEXT IN SOME OTHER
      FORMAT THAN 64 CHARACTERS
      WIDE?

      YES! AUTOTYPE has a screen redi-
      mension command. The screen can be
      set from 16 characters wide to 120
      characters wide. There's even horizon-
      tal scrolling to view the text! Once more,
      we're far beyond the competition!

      CAN IT HANDLE TEXT LARGER
      THAN MY COMPUTERS MEMORY?

      YES! Most other Word Processors de-
      mand that the entire text be inside the
      computer. AUTOTYPE allows you to
      "spool" your text from the disk. This
      means that you can have edit files that
      are over 200 type written pages long!!

      CAN IT UNDERLINE?
      CAN IT BOLDFACE?
      CAN IT INDENT?
      CAN IT HYPHENATE?

      YES! YES! YES! YES! YES! AUTOTYPE
      has ALL the standard Word Processor
      features including underlining text,
      boldface printing and paragraph in-
      dentation. AUTOTYPE also has soft
      and hard hyphens. Soft hyphens are
      used at the end of lines and disappear
      if moved!

      WHAT ABOUT INSERTING IN THE
      MIDDLE OF A WORD?

      Certainly! AUTOTYPE allows inserting
      anything anywhere! You can move
      single letters or entire chapters right
      into the middle of any word. Now
      THAT'S POWER!
    
```

```

      CAN IT SEARCH AND REPLACE?

      YES! But, there's more! AUTOTYPE al-
      lows simple searches or search and re-
      place. AUTOTYPE also allows wild
      card characters in the search string for
      probable matching! A very simple fea-
      ture that AUTOTYPE makes very power-
      ful!

      CAN IT DO AUTOMATIC PAGE
      NUMBERING AND TITLING?

      Of Course! Any length title up to the
      current line length. Page numbers can
      start anywhere. And if that's not
      enough, the number of blank lines
      below the title is adjustable!

      DOES IT HAVE "DYNAMIC" PRINT
      FORMATTING?

      OH YES! And with a flare! The pages
      that you see printed here were all
      printed from the same file. Only the print
      MACRO was altered! What's more,
      they were all printed on a standard se-
      rial printer. Complete "dynamic" print
      formatting can be accomplished with
      NO alteration of text!! Let's see the
      competition make that claim!

      CAN IT DO SUBSCRIPTS AND
      SUPERSCRIPTS?

      YES! Once again, AUTOTYPE has the
      features to be called a true proces-
      sor of words and not just another word
      processor.

      CAN IT VERTICAL TAB?

      YES! And do negative vertical tabs to
      the top of page also! This is invaluable
      for two column printing.

      CAN YOU ADJUST THE INDENT,
      LINE LENGTH AND
      JUSTIFICATION?

      COMPLETELY! Either in the text itself,
      by manual formatting commands or
      with a print MACRO. Only AUTOTYPE
      gives you that kind of choice!

      WILL IT EXECUTE A SERIES OF
      COMMANDS AUTOMATICALLY?

      YES! That's one of AUTOTYPE's stan-
      dard features. No other Word Process-
      or has the ease of use or the powerful
      commands that AUTOTYPE has.

      ARE THE TABS ADJUSTABLE?

      All tab stops are displayed graphically
      with a simple command. Tab removal
      and setting are simple cursor move-
      ments and a single key command! No
      more "guessing" where your tabs are
      set. They're all laid out in front of you!

      HOW MUCH DOES AUTOTYPE
      COST?

      $195. This question is the easiest to
      answer. It's simple. We want you to use
      your computer to its fullest extent! And
      we want you to be able to do it at a
      reasonable price. This is the one area
      where our competition is way ahead
      of us!! They simply charge more than
      we do!

      HOW DO I ORDER?

      We thought you'd never ask! Just fill
      out the order form below and mail to
      INFINITY MICRO. Or call us directly
      and place your order. It'll be shipped
      the same day.
    
```

```

      CAN I MOVE PARAGRAPHS
      AROUND?

      YES! AUTOTYPE has a Holding Buffer
      that can be used to save any amount of
      text and then Unhold it to the location
      you want. AUTOTYPE even allows you
      to do multiple Unholds!

      CAN I MERGE CUSTOMERS
      NAMES INTO LETTERS?

      YES! AUTOTYPE contains a "merge"
      character that may be placed any-
      where in text. Then, at the time text is
      printed, a separate file may be merged
      into the letter and then printed! An-
      other feature that NO OTHER WORD
      PROCESSOR has!

      CAN I ENTER TEXT IN SOME OTHER
      FORMAT THAN 64 CHARACTERS
      WIDE?

      YES! AUTOTYPE has a screen redi-
      mension command. The screen can be
      set from 16 characters wide to 120
      characters wide. There's even horizon-
      tal scrolling to view the text! Once more,
      we're far beyond the competition!

      CAN IT HANDLE TEXT LARGER
      THAN MY COMPUTERS MEMORY?

      YES! Most other Word Processors de-
      mand that the entire text be inside the
      computer. AUTOTYPE allows you to
      "spool" your text from the disk. This
      means that you can have edit files that
      are over 200 type written pages long!!

      CAN IT UNDERLINE?
      CAN IT BOLDFACE?
      CAN IT INDENT?
      CAN IT HYPHENATE?

      YES! YES! YES! YES! YES! AUTOTYPE
      has ALL the standard Word Processor
      features including underlining text,
      boldface printing and paragraph in-
      dentation. AUTOTYPE also has soft
      and hard hyphens. Soft hyphens are
      used at the end of lines and disappear
      if moved!

      WHAT ABOUT INSERTING IN THE
      MIDDLE OF A WORD?

      Certainly! AUTOTYPE allows inserting
      anything anywhere! You can move
      single letters or entire chapters right
      into the middle of any word. Now
      THAT'S POWER!
    
```

WORD PROCESSING POWER IS HERE! With AUTOTYPE®

Word Processors are here. Just thumb through the pages of this magazine. There are at least five different companies selling them. So, which one's for you? How do you judge the differences? And what about cost. Are you willing to pay the 300 plus dollars that some of the companies are asking?

We'll go ahead and compare! AUTOTYPE comes out ahead in EVERY category!

Features? AUTOTYPE has more powerful features than ANY other Word Processor on the market. But, don't take our word. Go ahead, compare! AUTOTYPE has an exclusive MACRO programming capability. No other Word Processor can make that claim. AUTOTYPE also has a scratch Holding Buffer. Again, no one else even comes close.

Price? AUTOTYPE beats 'em all! With a price tag of \$195, AUTOTYPE is well below the competition. But, again, don't just take our word. Go ahead, look for yourself. Then fill out the order form below to start processing words instead of using a word processor!

CAN I MOVE PARAGRAPHS AROUND?

YES! AUTOTYPE has a Holding Buffer that can be used to save any amount of text and then Unhold it to the location you want. AUTOTYPE even allows you to do multiple Unholds!

CAN I MERGE CUSTOMERS NAMES INTO LETTERS?

YES! AUTOTYPE contains a "merge" character that may be placed anywhere in text. Then, at the time text is printed, a separate file may be merged into the letter and then printed! Another feature that NO OTHER WORD PROCESSOR has!

CAN I ENTER TEXT IN SOME OTHER FORMAT THAN 64 CHARACTERS WIDE?

YES! AUTOTYPE has a screen redimension command. The screen can be set from 16 characters wide to 120 characters wide. There's even horizontal scrolling to view the text! Once more, we're far beyond the competition!

CAN IT HANDLE TEXT LARGER THAN MY COMPUTERS MEMORY?

YES! Most other Word Processors demand that the entire text be inside the computer. AUTOTYPE allows you to "spool" your text from the disk. This means that you can have edit files that are over 200 type written pages long!!

CAN IT UNDERLINE? CAN IT BOLDFACE? CAN IT INDENT? CAN IT HYPHENATE?

YES! YES! YES! YES! YES! AUTOTYPE has ALL the standard Word Processor features including underlining text, boldface printing and paragraph indentation. AUTOTYPE also has soft and hard hyphens. Soft hyphens are used at the end of lines and disappear if moved!

WHAT ABOUT INSERTING IN THE MIDDLE OF A WORD?

Certainly! AUTOTYPE allows inserting anything anywhere! You can move single letters or entire chapters right into the middle of any word. Now THAT'S POWER!

CAN IT SEARCH AND REPLACE?

YES! But, there's more! AUTOTYPE allows simple searches or search and replace. AUTOTYPE also allows wild card characters in the search string for probable matching! A very simple feature that AUTOTYPE makes very powerful!

CAN IT DO AUTOMATIC PAGE NUMBERING AND TITLING?

Of Course! Any length title up to the current line length. Page numbers can start anywhere. And if that's not enough, the number of blank lines below the title is adjustable!

DOES IT HAVE "DYNAMIC" PRINT FORMATTING?

OH YES! And with a flare! The pages that you see printed here were all printed from the same file. Only the print MACRO was altered! What's more, they were all printed on a standard serial printer. Complete "dynamic" print formatting can be accomplished with NO alteration of text!! Let's see the competition make that claim!

CAN IT DO SUBSCRIPTS AND SUPERSCRIPTS?

YES! Once again, AUTOTYPE has the features to be called a true processor of words and not just another word processor.

CAN IT VERTICAL TAB?

YES! And do negative vertical tabs to the top of page also! This is invaluable for two column printing.

CAN YOU ADJUST THE INDENT, LINE LENGTH AND JUSTIFICATION?

COMPLETELY! Either in the text itself, by manual formatting commands or with a print MACRO. Only AUTOTYPE gives you that kind of choice!

WILL IT EXECUTE A SERIES OF COMMANDS AUTOMATICALLY?

YES! That's one of AUTOTYPE's standard features. No other Word Processor has the ease of use or the powerful commands that AUTOTYPE has.

ARE THE TABS ADJUSTABLE?

All tab stops are displayed graphically with a simple command. Tab removal and setting are simple cursor movements and a single key command! No more "guessing" where your tabs are set. They're all laid out in front of you!

HOW MUCH DOES AUTOTYPE COST?

\$195. This question is the easiest to answer. It's simple. We want you to use your computer to its fullest extent! And we want you to be able to do it at a reasonable price. This is the one area where our competition is way ahead of us!! They simply charge more than we do!

HOW DO I ORDER?

We thought you'd never ask! Just fill out the order form below and mail to INFINITY MICRO. Or call us directly and place your order. It'll be shipped the same day.

Mail To:
INFINITY MICRO
P.O. BOX 4627
SANTA CLARA, CA 95050
(408) 988-1867

VIDEO
 Memory mapped Video at CC00 hex. as 64 characters by 16 lines. Processor Tech or equivalent.

*Cursor addressable terminal. (ADM-3A)
 *Cursor addressable terminal. (HAZELTINE 1500)

DISK
 CP/M on IBM standard 8"
 CP/M on Micropolis MOD I
 CP/M on Micropolis MOD II
 CP/M on North Star
 CP/M on Double Density 8"
Please specify Manufacturer.

NAME _____
ADDRESS _____
CITY _____ STATE _____ ZIP _____
PHONE _____

Please ship _____ AUTOTYPE disks and manuals immediately! Please find enclosed \$ _____ @ \$195/each.

*Available Nov-Dec of 1979
Copyright © 1979 Infinity Micro

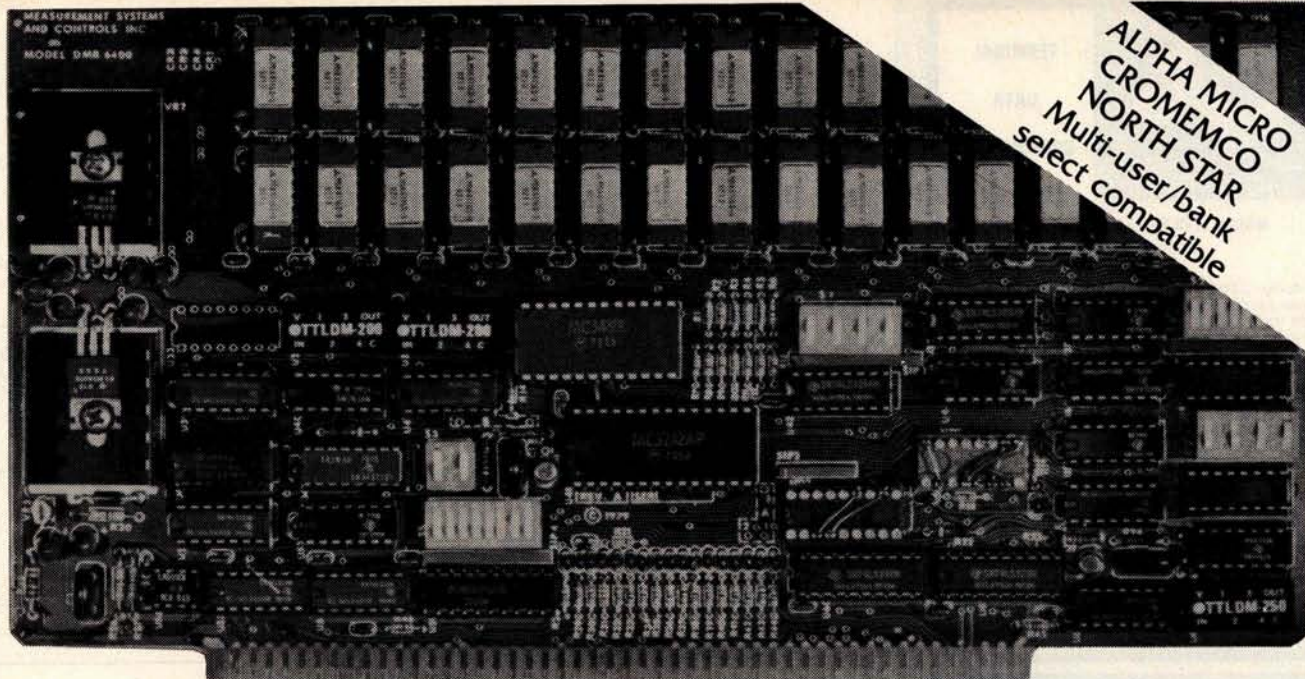

Model DMB-6400 Series dynamic 64k byte RAMS incorporate the features which are standard in the DM-6400 Series and adds bank select for multi-user-timesharing applications.

- ALPHA MICRO, CROMEMCO, and NORTH STAR output port bank select.
- Memory bank size can be incremented to 64k bytes in 16k increments.
- Four (4) 16k byte, functionally independent memory banks.
- Eight (8) 64k byte banks of memory per output port for expansion to 512k bytes for each output port.

Model DM-6400 Series dynamic 64k memory boards feature IEEE S-100 compatible timing and on board transparent refresh.

- Memory selectable and deselectable in 4k byte increments.
- 25 MHz on board crystal oscillator for independent timing.

DMB-6400 and DM-6400 Common Features:

- 4 MHz Z80 operation with no wait states.
- Tested and burned-in.
- Low power- 8 watts maximum.
- Reliable, expandable memories.

ONE YEAR GUARANTEE

THE FOLLOWING PRODUCTS ARE AVAILABLE

- | | | | |
|---|---|--|--|
| <input type="checkbox"/> DMB-6400/64K RAM | <input type="checkbox"/> DMB-3200/32K RAM | <input type="checkbox"/> DM-6400/64K RAM | <input type="checkbox"/> DM-3200/32K RAM |
| <input type="checkbox"/> DMB-4800/48K RAM | | <input type="checkbox"/> DM-4800/48K RAM | |

U.K. & EUROPEAN REPRESENTATIVE:

ABACUS COMPUTERS LTD.
62, NEW CAVENDISH STREET
LONDON, W1M 7LD U.K.
TEL: 01-580/8841 TELEX: 881-3085

AUSTRALIAN REPRESENTATIVE:

COMPUTERLAND OF MELBOURNE
555 COLLINS STREET
MELBOURNE, VIC3000
TEL: 625581

MEASUREMENT
systems & controls
incorporated

867 North Main Street ● Orange, CA 92668
Telephone: 714/633-4460

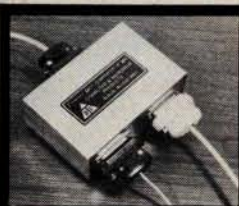

**TERMINAL
DATA
CORPORATION**

MODEL 1200 RS-232 DATA SPLITTER
available in kit form

Model 1200K gives the terminal or micro-processor user a second interface for a printer, plotter, cassette or tape drive. It operates at any speed & isolates the two output devices from each other, while providing 2 RS-232 interfaces from the terminal or microprocessor.

The kit consists of 3 RS-232 connectors, printed circuit board, all necessary components, enclosure, mounting hardware & assembly instructions \$59

write or call

TERMINAL DATA CORP.
11878 Coakley Cir.
Rockville, MD 20852
(301) 881-7655

Circle 371 on inquiry card.

**TRS-80, PET,
APPLE,
SORCERER
Hardware/Software
Systems**

Available now:

- **HAM INTERFACE**--including the most sophisticated RTTY systems money can buy.
- **Baudot and ASCII printer interfaces.**
- **Electra Sketch®**, **ANIMATION GRAPHICS Compiler**

Write or call for free catalog

MACROTRONICS, inc.

P.O. Box 518 (A) Keyes, CA 95328
(209) 634-8888 / 667-2888 (R) (S)
We are experiencing telephone difficulties, please keep trying.

Circle 206 on inquiry card.

SUPPLIES



- FLOPPY DISKS, MINI OR STANDARD MEMOREX OR 3M
- 3M DATA CARTRIDGES DC300A, DC100A
- 3M DIGITAL CASSETTES
- 3M OR MEMOREX AUDIO CASSETTES, C-60
- 3M DISK CARTRIDGES

WE OFFER:

- COMPETITIVE PRICING
- IMMEDIATE DELIVERIES (Any Quantity)
- UNCONDITIONAL GUARANTEE

BETA BUSINESS SYSTEMS

8389 VICKERS ST., #G
SAN DIEGO, CA 92111
(714) 565-4505

Circle 33 on inquiry card.

Power of two

Short tables that have more than 1 byte per entry are easier to work with if the number of bytes per entry is a power of 2. This may waste some space in the table, but may save more space and also time in the code which handles the table. Computing an offset into a table that is a power of 2 can be done with a series of shifts instead of the integer multiplication that would otherwise be required.

TABLE: BYTES 36,24,36
BYTES 36,22,37
BYTES 38,23,38
BYTES 35,20,34

TABLE: BYTES 36,24,36,00
BYTES 36,22,37,00
BYTES 38,23,38,00
BYTES 35,20,34,00

Use the stack

Instead of saving temporary values at some memory location, they can often be saved on the stack. This usually holds true, even when manipulating data on top of the stack. The details are too machine dependent to give an example, but some of the newer microprocessors recognize this by having more than one hardware-implemented stack pointer.

Combine instructions

It is sometimes easy to miss the possibility of combining instructions. One situation which can be missed is when one can combine a symbolic value with a constant at assembly time rather than at execution time.

LOAD IMMEDIATE ADDRESS
ADD IMMEDIATE 1

LOAD IMMEDIATE ADDRESS + 1

Multiple additions

Normally, several ADD IMMEDIATE instructions in a row would be a bad idea. In a frequent situation, however, it can be very useful. Suppose one wants to pass a number to a subroutine and have the subroutine return 1, 2, or 3, depending on whether the passed number was 5, 12, or 13 respectively. Note that the optimization shown is of space at the expense of some time.

COMPARE IMMEDIATE WITH 5
JUMP IF EQUAL TO ONE
COMPARE IMMEDIATE WITH 12
JUMP IF EQUAL TO TWO
LOAD IMMEDIATE 3
RETURN
ONE: LOAD IMMEDIATE 1
RETURN
TWO: LOAD IMMEDIATE 2
RETURN

COMPARE IMMEDIATE WITH 5
JUMP IF EQUAL TO ONE
COMPARE IMMEDIATE WITH 12
JUMP IF EQUAL TO TWO
ADD IMMEDIATE -6
ONE: ADD IMMEDIATE 6
TWO: ADD IMMEDIATE -10
RETURN

[Editor's note: The techniques presented here tend to produce nonstructured programs. The programmer must make a choice between readable structured code and speed optimized code. Structured programming techniques are recommended for all programs not requiring crucial space and time specifications . . . RGAC/■

8P2SM PARALLEL/SERIAL I/O BOARD WITH MODEM

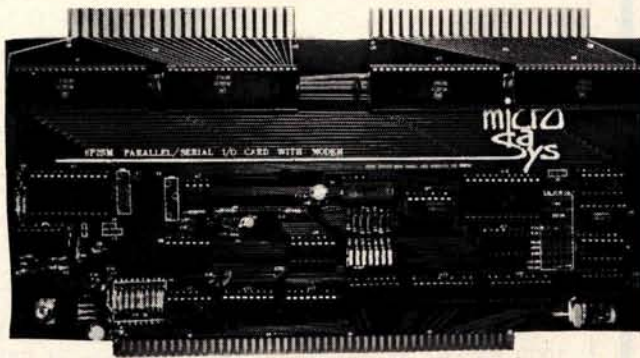

\$149 kit

**plus new
Byte Cassette
Interface!**

PARALLEL PORTS: 8 Ports, 64 total bi-directional bits.

SERIAL PORTS: 2 Serial Ports with associated control lines

One Port TTL or RS-232.
One Port TTL or MODEM.

AVAILABLE BAUD RATES:

307.2 kilobaud	1760 baud
153.6 kilobaud	1200 baud
76.8 kilobaud	600 baud
38.4 kilobaud	300 baud
19.2 kilobaud	150 baud
9600 baud	110 baud
4800 baud	75 baud
2400 baud	27.5 baud

or any user supplied baud rates up to 500 kilobaud.

MODEM: Full Duplex, answer or originate, 300 Baud or cassette interface

BUS TYPE: S-100

PRICE: \$149 (kit)
\$199 (assembled and tested).

6809!

**S-100 Compatibility.
6809 Computability.**

- 1K RAM
- 10K PROM space
- MONBUG II monitor included
- 2400 baud cassette interface
- 20 I/O lines
- RS-232 level shifters
- Real time clock
- DMA
- Parallel keyboard input
- Memory-mapped video firmware
- Fully S-100 compatible (including 8080 type I/O)
- A complete system, ready to use.

- 6809
- 16 bit internal arithmetic
- Hardware multiplication
- Two stack pointers
- Two index registers
- 18 addressing modes
- Fully relocatable code
- Five interrupts
- Up to three times the throughput of a 4MHz Z-80



MD-690a Single Board Computer
\$239 kit \$299 assembled

Please rush the following:

- CPU Card (kit) I/O Card (assembled)
- CPU Card (assembled) I/O Card (kit)

NAME _____
COMPANY _____
ADDRESS _____
CITY _____
STATE/ZIP _____

MicroDaSys

P.O. Box 36051
Los Angeles, CA
90036
[213] 935-4555



CA residents add 6%

MICROTEK OUTPERFORMS CENTRONICS



**CHECK
THE CHART**

SEE PAGE 19

Languages Forum

And Its Interest SNOBOLs

Dr Stefan M Silverston, 23 Deerhaven Dr,
Nashua NH 03060

I was pleased to see Mr Bruce Burns' letter in the June 1979 BYTE. As one of the small number of SNOBOL4 implementors (SNOBAT for IBM 360) around, I have always felt SNOBOL4 has much to offer the programmer, in many areas of application. It has some features provided by no other programming language known to me.

Without meaning to dampen anyone's enthusiasm, I should mention that SNOBOL4's syntax and control structures are rather lacking by today's standards. SNOBOL programs tend to be a bit hard to read, due largely to the ubiquitous blank, which can denote (1) string concatenation, (2) pattern matching, and (3) separation between labels and statement subjects. Flow-of-control also is rather opaque. The prevalence of side-effect-driven programming, for example, via value assignment in pattern matches, also detracts from program readability and maintainability. These flaws could well be remedied in any new SNOBOL implementation.

As Mr Burns points out, there are good reasons why SNOBOL4 has not been implemented on microcomputers. For one thing, SNOBOL implementations usually require considerable memory, more than what is ordinarily available on microsystems. Further, SNOBOL tends to run rather slowly in many implementations, even on large machines. This could be exaggerated for microcomputers, where storage management and swapping with peripheral memory might be necessary.

Of the 8-bit microprocessors in wide use, the Z80, with its block moves and compares, would probably be the most amenable to SNOBOL4 implementation. I intend to tackle SNOBOL4 development on my own Z80 floppy disk system in the near future, incorporating some improvements as discussed above.

SNOBOL4 should be a lot easier, as well as more efficient, with the new generation of 16-bit microprocessors. A SNOBOL implementation for the Z8000, say, should be a "natural". ■

Languages Forum is a feature which is intended as an interactive dialog about the design and implementation of languages for personal computing. Statements and opinions submitted to this forum can be on any subject relevant to its purpose of fostering discussion and communication among BYTE readers on the subject of languages. We ask that all correspondents supply their full names and addresses to be printed with their commentaries. We also ask that correspondents supply their telephone numbers, which will not be printed.

PET PRODUCTS
Programs — Workbooks
for Floppy Disk — for Cassette



Dealer Inquiries Invited

Put your PET to work!

T I S

PROGRAMS	WORKBOOKS
SW-1* MAILB mailing list system	WB-1 Getting Started with Your PET \$3.95
SW-2* CHECKBOOK record	WB-2 PET String and Array Handling \$3.95
SW-3* ACCOUNTS keep track of who owes you how much	WB-3 PET Graphics \$4.95
SW-4 MEDIT creates and maintain data files	WB-4 PET Cassette I/O \$4.95
SW-5* CALENDAR appointments, meetings at a glance	WB-5 Miscellaneous PET Features \$3.95
	WB-6 PET Control and Logic \$3.95

*These programs are special purpose data base management systems. They all can:

- Sort numeric or string fields
- Select based on numeric or string (=)
- Select based on substring match
- Select based on range of entry number

Prices: \$9.90 each for programs using cassette storage for data
 \$12.95 each using sequential floppy disk storage for data.
 \$5.95 each for instruction manual, approximately 40 pages.

Add \$1.50 for shipping and handling.

Money back guarantee

TIS
P.O. Box 921, Dept. B
Los Alamos, NM 87544

PET is a trademark of Commodore Business Machines

Tic-Tac-Tactics

John C Miller, 110 Riverside Dr, New York NY 10024

The May 1979 BYTE article on Tic-Tac-Toe (page 196) raises more interesting questions of programming philosophy and esthetics than those referred to in the article itself. No doubt Mr. Hinrichs' program plays an aggressive game, and never loses, as he claims. But his approach is also curiously limited in that the program is only able to play the first move side of the game, and this limitation seems the result of Mr. Hinrichs' reliance on data entries to dictate most of his move sequences. A program capable of playing the second move would be much more difficult using his methods, which are also unsatisfactory on principle because they fail to take proper advantage of the computer's most powerful capabilities.

A more rational approach, which actually involves *computing* each move rather than looking it up in a table, goes as follows:

- Win if possible; otherwise
- Block the opponent from winning on his next move if necessary; otherwise
- Set a trap (2 ways to win on your following move) if possible; otherwise
- Avoid any move allowing the opponent to set a trap on his next move, and then
- Make a (not previously avoided) move forcing (under threat of immediate loss) the opponent to make a move allowing you to set a trap, if possible; otherwise
- Avoid any move allowing opponent to force you into a move allowing him to set a trap, if possible; otherwise,
- Among moves not previously avoided, choose one which allows the opponent to blunder by choosing a move which allows you to set a trap, and then
- Among moves not previously avoided, choose one which allows the opponent to blunder by choosing a move which allows you to win on your following move, if possible; otherwise
- Choose randomly among moves not previously avoided.

As a suggestion to a reader interested in implementing this strategy, which evidently allows elegant use of sub-routines, it is further suggested that the board be coded internally using the 3-by-3 magic square:

```

2 9 4
7 5 3
6 1 8

```

for which a win corresponds precisely to playing 3 numbers whose sum is 15.

The 9-step strategy outlined above has all the desirable properties of Mr. Hinrichs' program, including aggressiveness both in seeking wins and allowing opponent mistakes. In addition, it plays both first and second move equally well and "feels" right, in that it allows the computer to compute, instead of looking up moves in a data table. ■

DYNACOMP

Quality software for: Altair
North Star
TRS-80 (Level II)

Sophisticated software written by recognized computer professionals. Each program is supplied with complete documentation. All programs can be run with standard terminals (32 characters or wider) and within 12K program memory space.*

FLIGHT SIMULATOR

(as described in SIMULATION, Volume II)

- Realistic and extensive three-dimensional simulation of take-off, flight and landing.
- Based on aerodynamic equations and real airfoil.
- Practice instrument approaches and navigation using radials and compass headings.

Price: \$17.95

SIMULATION, Volume II (BYTE Publications): \$6.00

VALDEZ* (Requires 16K of program memory)

- Exciting simulation of supertanker navigation in Prince William Sound and Valdez Narrows using radar map.
- Detailed physical model of ship response and tidal patterns.
- Chart course through ship and iceberg traffic.

Price \$14.95

BRIDGE 2.0

- Complete contract and duplicate bridge game.
- Computer both **bids** and **plays**.
- Computer will play offense or defense according to the bid.
- Challenging entertainment for the advance player.
- Excellent learning tool for the bridge novice.

Price: \$17.95

HEARTS 1.5

- An entertaining computer simulation of this popular card game.
- Play against two computer opponents.
- Beware the Black Maria!

Price: \$14.95

NORTH STAR TEXT EDITOR

(Update of program described in BYTE, June 1979)

- Designed as an easy-to-use (and remember) basic text editor.
- Works through unmodified North Star DOS.
- Line-oriented editing, variable line width, simple paragraph indexing.

Price: \$10.95 (Available only on North Star diskette)

NORTH STAR COMPRESSION PROGRAM

- Removes all unnecessary spaces and remark statements from program.
- Requires only a single disk drive.
- Any size program may be processed.
- Increases execution speed of programs while using less memory.

Price: \$9.95 (Available only on North Star diskette.

Requires release 4 or higher North Star BASIC.)

Except where noted, all software is available on North Star diskettes, and Altair and TRS-80 cassettes.

Additionally, Microsoft BASIC ASCII listings are available on paper tape and cassette (modem compatible, 300 baud).

All orders processed within 48 hours. Write for more detailed descriptions of these and other programs available from **DYNACOMP**.

DYNACOMP

P.O. Box 162

Webster, New York, 14580

New York residents please add 7% NYS sales tax.

Drop JCL and Start with WFL

Donald J Gregory, 1011 Rose Marie, #39
Stockton CA 95207

I agree with James Jones ("How to Define an OS Which Does Not Need a Wizard," April 1979 BYTE, page 245) that we must not repeat the mistakes of the past when designing operating systems for microcomputers, especially when designing the user interface. With most users writing their programs in high-level languages, it is absurd for them to be forced to write their system-interface routines in a low-level quasi-assembler designed for the convenience of the machine. What we need is an interface that is strongly based on a well-known, powerful, and easy-to-use high-level language, such as Pascal, or its progenitor, ALGOL.

Such an interface already exists — on one line of the big machines. The Burroughs Corporation Large Systems computers (series B7000/B6000) have a user interface called Work Flow Language (WFL) which is essentially a limited ALGOL with a few extensions. The basic system instructions are all handled by a few very simple commands: to run a program one simply writes RUN and the program name; to compile a program, the command is

COMPILE, the program name, and the compiler's name; to copy a file, one uses the COPY command; to erase a file, simply REMOVE it; and to rename a file, just CHANGE its title. The remainder of this language consists of structures familiar to every Pascal and ALGOL user: it supports variables of type REAL, INTEGER, BOOLEAN, and STRING; for control structures there are the WHILE...DO, DO...UNTIL, IF...THEN...ELSE statements, and the ever unpopular GOTO statement. Subroutines are supported (with parameters) and values can be passed between WFL routines and the applications programs they run.

The most impressive aspect of Work Flow Language (WFL) is its handling of peripheral device assignments. Each program is permitted to have default specifications for its files in its own code, which frees the user from constantly defining his files in his WFL. But if those files in the program are not what is wanted for a particular run, the files can be redescribed in the WFL (using the ALGOL syntax for a file declaration), and the definitions in the WFL will *override* those in the program.

The use of a high-level user interface turns out to be more feasible for overall job construction. While working on an IBM-to-Burroughs conversion a year ago, I wrote a Job Control Language (JCL) to a WFL translator, and found that as many as 50 different JCL jobs could be algorithmically converted into only 1 WFL job.

There is so much power, flexibility, and convenience available in WFL that any operating system designer

The ESCON SR-101 Printer/Typewriter \$1895

At last, a letter quality printer at a price everyone can afford!

- Receive-only printer offers dual pitch, self-correcting typing
- Accepts IBM typing balls and ribbons
- Serviceable by anyone knowledgeable in SELECTRIC® repair.
- Interfaces with virtually any minicomputer including Apple, TRS-80, Commodore Pet, North Star and more

ORDERS NOW BEING ACCEPTED
Act now - quantities are limited!
Dealer Inquiries Invited.



DTI
Office
Products,
Inc.

8002-D Haute Court · Springfield, Virginia 22150 · (703) 671-7503

The selection is great. The choice is easy.

Meet MINIMAX.

The most advanced, least expensive computer
ever created.

Today, the selection of microcomputers is incredibly large. But the choice of businessmen, scientists, architects and engineers is clearly MINIMAX. It's the new microcomputer that's beyond compare. But please do.

- 108,544 Bytes of internal memory
- Choice of either 800 kilobytes or 2.4 megabytes of floppy disc memory
- Disc information retrieval takes only 2 seconds per 30,000 characters
- Uses lightning fast 2 megahertz 6502 CPU
- Resident System Software (ROM)
- High Resolution Graphics (240X512) with split screen capabilities
- Superior business software package
- PAGEMATE™ DATA BASE
- All programs are integrated
- Software development tools

MINIMAX by Compu-Think Corp. is distributed east of the Mississippi, except in New England, by DTI Office Products. If you're a dealer or end-user looking for the clear choice in microcomputers, and want unprecedented sales and service support, contact us for more details.

MINIMAX I With 800K eternal memory dual-disc drives (5¼") **Only \$4495**

MINIMAX II With 2.4 Megabyte eternal memory dual-disc drives (8½") **Only \$5995**
(Printer not included)

Send Me More On MINIMAX!

Name _____

Company _____

Address _____

City _____

State _____ Zip _____

B1079

DEALER INQUIRIES INVITED

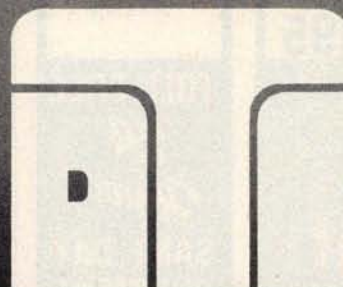

**DTI
Office
Products,
Inc.**

8002-D Haute Court · Springfield, Virginia 22150 · (703)671-7503

See and Copy Tape Data



use TRcopy

WITH YOUR LEVEL II TRS-80*

TRcopy is a cassette tape copying system that lets you SEE what your computer is reading.

COPY ANY CASSETTE TAPE**

With the TRcopy system you can copy any TRS-80 Level II cassette tape whether it is coded in Basic or in machine language. You can also copy data created by programs and you can copy assembler listings.

YOU CAN SEE THE DATA

As the tape is being loaded, you can SEE the actual data byte-for-byte from the beginning to the end of the program. Up to 320 bytes are displayed at one time. ASCII characters are displayed on the first line and hexadecimal code is displayed on the following two lines. Data is displayed exactly as it is input including memory locations and check sums.

IDENTIFY PROGRAMS

With TRcopy you can identify programs on cassette tapes without written documentation because you can SEE the filename. If you forget to label a tape, you can use TRcopy to display the tape contents and identify the cassette.

VERIFY CASSETTE TAPES

With TRcopy you can verify both the original tape and the tape copies. You can make certain that your machine reads the original tape correctly and that it makes byte-for-byte copies. TRcopy also counts as it reads giving you the exact length of the data.

MAKE BACKUPS FOR YOUR PROGRAMS

Now you can make backup copies of your valuable programs. Many times a cassette that you make will load better than one that is mass produced. The original can then be kept as a backup in case the copy is damaged.

MAKE COPIES OF YOUR SOFTWARE

If you are in the software business you can use TRcopy to make tested copies of your programs for sales distribution. TRcopy produces machine language tapes that are more efficient than those produced by the assembler itself.

RECOVER FAULTY DATA

With TRcopy you can experiment with the volume and level controls and you can SEE what the computer is reading--even if your computer will not read the data through normal read instructions! In this way it is possible to read and copy faulty tapes by adjusting the volume control until you SEE that the data is input properly.

SIMPLE - FASCINATING - FUN

TRcopy is not only a practical utility program. It is also a fascinating graphics program that lets you SEE, for the first time, cassette data as your computer is reading it. And it's as simple as 1-2-3. Just load, verify and copy. You will now be able to use cassette tapes with confidence knowing that TRcopy is there when you need it.

The TRcopy system is a machine language program with documentation explaining tape leaders, sync bytes, check sums and other formatting conventions. With the TRcopy system, you can SEE what you are doing!

TRcopy System Including
Cassette Tape and Documentation

39⁹⁵
POST PAID

Orders accompanied by money order or cashier's check mailed same day.
Orders paid by other check shipped in 14 days. No COD's. Return within 10 days for a full refund if you are not satisfied.

N.D. Orders Add 3% Sales Tax. *TRS-80 is a trademark of the Tandy Corporation. **You cannot copy the TRcopy cassette.

ORDER FROM

Data/Print

DEPT. BT, BOX 903, FARGO, N.D. 58107

CALL IN
YOUR
ORDER
Now!

Call Toll-Free 24 Hours

If you have a Master Charge or a Visa credit card, you can call toll-free from the nearest telephone and have your TRcopy system on its way to you today. Call 1-800-437-4144 anytime - 24 hours a day.

For calls from N.D., Hawaii or Alaska call collect 1-701-237-0216

CALL RIGHT NOW!



NOW USE TRCOPY WITH YOUR PRINTER

Included at no extra cost - Now you can use the TRcopy system to output tape data to a line printer or a quick printer. The data is printed exactly as it is input from the tape including file names, memory locations and check sums. A printed copy can be especially helpful in the analysis or recovery of records contained in tape data files.

ORDER YOUR TRCOPY SYSTEM NOW!

TOLL FREE

24
Hours

SAME DAY
SHIPMENT

must experience it before committing us all to a travesty such as JCL. The user's manual on WFL published by Burroughs Corporation does not serve as an adequate introduction to the language (it was not designed for that purpose). To help bridge this information gap, I have published a 275-page document, *the B6700 WFL Primer*, which can be obtained for \$15 from Gregory Publishing Co, A C Ridlon, distributor, 6090 S Sterne Pkwy, Littleton CO 80120.

In the design of a user interface, let us not slide back into the dark ages. With WFL as an inspiration, we can begin in a user-friendly environment and go on from there. ■

Case Statements and Related Topics

Peter Grogono, 73 Roxton Crescent
Montreal West Quebec, CANADA H4X 1C7

David Faught made several comments and suggestions concerning multiple conditions in the BYTE Language Forum (December 1978, page 176). The following notes are written in response to his ideas and suggestions.

First, some preliminary observations. The FORTRAN statement that corresponds most closely to the case statement is not the "numeric IF" statement; it is the "computed GOTO" statement, which has the following form:

GOTO (1,2,3,4,5),N

The numbers are statement labels, and N is an integer variable. If $1 \leq N \leq 5$, control will be transferred to the corresponding statement. If $N < 1$ or $N > 5$, the effect of the statement is undefined; most FORTRAN systems abort the program and print a diagnostic message.

FORTRAN IV, which is the most common version of FORTRAN today, has two forms of IF statement. The older form is the "numeric IF" statement. It is confusing and not particularly useful, but it was the only form of IF statement provided in FORTRAN II. The other IF statement, the "logical IF," was introduced in FORTRAN IV, but the numeric IF was retained so that FORTRAN II programs could be compiled by FORTRAN IV compilers. The FORTRAN "numeric IF" statement, in which E is an integer or real expression and the numbers are once again statement labels, is written in the following way:

IF (E) 1,2,3

Control is transferred to a labeled statement according to the value of E:

**RADIO SHACK COMPUTER OWNERS
TRS-80 MODEL I AND MODEL II**

TRS-80™ MONTHLY NEWSLETTER

- PRACTICAL APPLICATIONS
- BUSINESS
- GAMBLING • GAMES
- EDUCATION
- PERSONAL FINANCE
- BEGINNER'S CORNER
- NEW PRODUCTS
- SOFTWARE EXCHANGE
- MARKET PLACE
- QUESTIONS AND ANSWERS
- PROGRAM PRINTOUTS
- AND MORE

PROGRAMS AND ARTICLES PUBLISHED IN OUR FIRST 12 ISSUES INCLUDE THE FOLLOWING:

- A COMPLETE INCOME TAX PROGRAM (LONG AND SHORT FORM)
- INVENTORY CONTROL
- STOCK MARKET ANALYSIS
- WORD PROCESSING PROGRAM (FOR DISK OR CASSETTE)
- LOWER CASE MODIFICATION FOR YOUR VIDEO MONITOR OR PRINTER
- PAYROLL (FEDERAL TAX WITHHOLDING PROGRAM)
- EXTEND 16-DIGIT ACCURACY TO TRS-80 FUNCTIONS (SUCH AS SQUARE ROOTS AND TRIGONOMETRIC FUNCTIONS)
- NEW DISK DRIVES FOR YOUR TRS-80
- PRINTER OPTIONS AVAILABLE FOR YOUR TRS-80
- A HORSE SELECTION SYSTEM***ARITHMETIC TEACHER
- COMPLETE MAILING LIST PROGRAMS (BOTH FOR DISK OR CASSETTE SEQUENTIAL AND RANDOM ACCESS)
- RANDOM SAMPLING***BAR GRAPH
- CHECKBOOK MAINTENANCE PROGRAM
- LEVEL II UPDATES***LEVEL II INDEX
- CREDIT CARD INFORMATION STORAGE FILE
- BEGINNER'S GUIDE TO MACHINE LANGUAGE AND ASSEMBLY LANGUAGE
- LINE RENUMBERING
- AND CASSETTE TIPS, PROGRAM HINTS, LATEST PRODUCTS COMING SOON (GENERAL LEDGER, ACCOUNTS PAYABLE AND RECEIVABLE, FORTRAN-80, FINANCIAL APPLICATIONS PACKAGE, PROGRAMS FOR HOMEOWNERS, MERGE TWO PROGRAMS, STATISTICAL AND MATHEMATICAL PROGRAMS (BOTH ELEMENTARY AND ADVANCED) . . . AND

FREE WORD PROCESSING PROGRAM (Cassette or Disk)
For writing letters, text, mailing lists, etc., with each new subscriptions or renewal.

↳ LEVEL II RAM TEST -

Checks random access memory to ensure that all memory locations are working properly.

SEND FOR OUR 36 PAGE SOFTWARE CATALOG (INCLUDING LISTINGS OF HUNDREDS OF TRS-80 PROGRAMS AVAILABLE ON CASSETTE AND DISKETTE). \$2.00 OR **FREE** WITH EACH SUBSCRIPTION OR SAMPLE ISSUE.

COMPUTRONICS!
MATHEMATICAL APPLICATIONS SERVICE™

Box 149 New City, New York 10956



24 HOUR ORDER LINE
(914) 425-1535



ONE YEAR SUBSCRIPTION \$24
TWO YEAR SUBSCRIPTION \$48
SAMPLE OF LATEST ISSUE \$ 4

START MY SUBSCRIPTION WITH ISSUE _____
(#1 - July 1978 • #7 - January 1979 • #12 - June 1979)

NEW SUBSCRIPTION _____ RENEWAL _____

CREDIT CARD NUMBER _____ EXP. DATE _____

SIGNATURE _____

NAME _____

ADDRESS _____

*** ADD \$6/YEAR (CANADA, MEXICO) - ADD \$12/YEAR AIR MAIL - OUTSIDE OF U.S.A., CANADA & MEXICO ***

$E < 0$ goes to 1, $E = 0$
goes to 2, $E > 0$ goes to 3.

The motivation for the three-way branch in numeric IF statements is efficiency. All computers have instructions which compare the contents of a register with zero, but many have no instructions for directly comparing the contents of two registers. Thus, the Boolean expression $A > B$ is usually evaluated in machine language as $A - B > 0$. In FORTRAN II the programmer was forced to convert all comparisons into comparisons with zero, since the compiler would not do this for him. In practice, three-way branches are required less frequently than two-way branches in most programming applications. In FORTRAN II programs, IF statements in which the three branching labels are all different are comparatively rare; in most cases, two of the labels are the same.

When a three-way branch is really required, it can be coded in an ALGOL-like language, such as Pascal, in this way:

```
if E < 0
  then s1
else if E = 0
  then s2
else { E > 0 } s3
```

where $s1$, $s2$, and $s3$ are simple or compound statements. However, this kind of code in a Pascal program is usually an indication of tricky programming, which Pascal is in-

tended to discourage. If the expression E occurs naturally in the program, and happens to have negative, zero, or positive values, the above statement is appropriate.

It is more likely, however, that E is some kind of flag, set elsewhere in the program to -1 , 0 , or $+1$. If this is the case, it is a much better use of Pascal to define a special type for the flag, enumerate its values, and use the Pascal case statement:

```
type
  flag = (down, halfmast, flying);
var
  mapleleaf : flag;
...
case mapleleaf of
  down : s1;
  halfmast : s2;
  flying : s3
end
```

This example leads to my principal topic: case statements. First, consider the Pascal case statement. An expression (the case selector) is evaluated, and the statement within the scope of the case keyword whose label has the same value is executed. The compiler will usually compile a case statement into a table of jump instructions in the object code, so it must be possible to map the values of the expression to the integers. In the example above, the compiler would map *down*, *halfmast*, and *flying* to the integers 0 , 1 , and 2 , respectively. Most Pascal compilers would compile a 1000 word table for the following statement:

```
case number of
  1 : s1;
  2 : s2;
  1000 : s3
end
```

Many people have commented about the absence of an "escape" clause in the Pascal case statement. How do you tell the compiler to take special action if there is no label which matches the value of the case selector? Pascal provides a very powerful and useful notation for set operations, and tests on sets can be used to guard case statements in this way:

```
if selector in [1,2,3,7,8,9,10]
  then
    case selector of
      1,2,3, : s1;
      7,8,9,10 : s2
    end
  else error
```

This statement acts in the following manner: it decides if the value of the selector is acceptable. To be acceptable it must have one of the values in the list enclosed by square brackets, which is a Pascal set constant. If the value is acceptable, the appropriate statement ($s1$ or $s2$) is selected by the case statement and executed; otherwise the procedure *error* is called. The example draws atten-

HIGH SPEED PRINTER

"OKIDATA CP.110" Prints an 8-1/2"
by 11" page in less than 60 seconds.

- Modular power supply 110/220 V. with circuit breaker, power cord & on/off switch
 - Self test circuit included
 - Full 80 character lines
 - High speed: 110 characters per second
 - Bidirectional print
 - Uses low cost standard 8-1/2" TTY paper
- INTERFACE FOR
TRS80 & Apple ... \$100.00
Service Manual ... \$ 40.00

\$650⁰⁰
REG. \$1200.00

BRAND NEW
INDUSTRIAL SURPLUS



INTERTUBE TERMINAL

\$779⁰⁰

SPECIAL
INTRODUCTORY
PRICE

Shipped Freight Collect

EXPORT BUSINESS
WELCOME

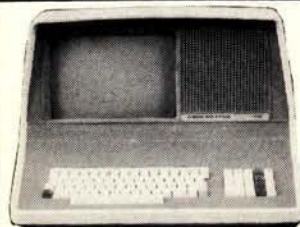

- 12" Display
- Numeric Keypad
- Reverse Video
- Upper & Lower Case
- Line, Char. Insert/Delete

INTERNATIONAL ELECTRONICS EQUIPMENT CORP.

P.O. BOX 522542, MIAMI, FLORIDA 33152 • (305) 595-2386



tion to a minor inconsistency in Pascal. The set expression [1,2,3,7,8,9,10] can be abbreviated to (1..3,7..10), but the case labels cannot be abbreviated in this way. It is tempting to suggest that the inconsistency be resolved by allowing case labels to be abbreviated in the same manner as set constants, but this obscures the really interesting point, which is that the case labels are, in fact, set constants themselves.

The most consistent way to write the above statement is this:

```

if selector in [1..3,7..10]
then
  case selector of
    [1..3] : s1;
    [7..10] : s2
  end
else error

```

This notation can be easily extended, as the next example shows. (Assume that *ch* is a letter, and that the three cases 'P', 'X', and "other" are to be distinguished; the set A-B contains all members of a set which are not also members of B):

```

case ch of
  ['P'] : s1;
  ['X'] : s2;
  ['A'..'Z'] - ['P','X'] : s3
end

```

If, however, the case statements are to be executed efficiently, the compiler must be able to evaluate the label expressions during compilation in order to generate a jump table. This implies that the case labels must not contain variables.

Enclosing the case statement in an if statement does not really solve the problem because we still have to write the acceptable case labels twice; once in the if condition, and once in the case statement itself. The only way around this is to allow an else or otherwise label, followed by a statement which is executed if there is no matching case label. Several of the more recent Pascal compilers provide this option.

As Faught pointed out in his article, the conventional if statement can also be extended in other ways. Consider the recursive definition of Ackermann's function, which can be written in Pascal in the following way:

```

if m = 0
then a := n + 1
else if n = 0
then a := a(m-1,1)
else a := a(m-1,A(m,n-1))

```

This could be written more elegantly using a form of the case statement in which labels are Boolean expressions:

```

case
  m = 0 : a := n + 1;
  n = 0 : a := a(m-1,1);
  (m > 0) & (n > 0):
  a := a(m-1,a(m,n-1))
end

```

Case statements of this kind must be defined carefully. Consider the general form of the statement:

```

case
  b1 : s1;
  b2 : s2;
  ...
  bn : sn
end

```

in which *b1*, *b2* ... *bn* are Boolean expressions (sometimes called "guards") and *s1*, *s2* ... *sn* are statements. When this case statement is executed, there are three possibilities:

- None of the Boolean expressions are true;
- Exactly one of the Boolean expressions is true;
- More than one of the Boolean expressions is true.

In the first case we can say either that the statement has no effect or, if we are designing a strict language, that it is illegal. In the second situation there is no problem. In the third situation, we can either declare the statement il-

PET PRINTER ADAPTER

GET HARD COPY FROM YOUR
COMMODORE PET USING A
STANDARD RS-232 PRINTER

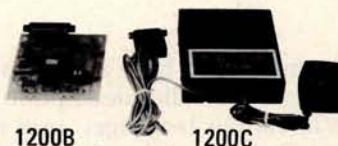

The CmC ADA 1200 drives an RS-232 printer from the PET IEEE-488 bus. Now, the PET owner can obtain hard copy listings and can type letters, manuscripts, mailing labels, tables of data, pictures, invoices, graphs, checks, needle-point patterns, etc., using a standard RS-232 printer or terminal.

\$98.50 ADA 1200C
Assembled and tested

\$169.00 ADA 1200C
With case, power supply
and RS-232 connector



Order direct or contact your local computer store.
Add \$3.00 for postage and handling per order.

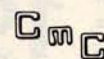

CONNECTICUT microCOMPUTER
150 POCONO RD. BROOKFIELD, CT 06804
(203) 775-9659 TLX: 7104560052

legal, execute only one statement, or execute all the statements whose guards are true. If we select the last alternative (executing more than one statement), we must specify the precise order in which guards will be evaluated and statements executed. The necessity for this can be seen from this example:

```

case
  x < 0 : x := 0;
  x = 0 : x := 10;
  x ≥ 0 : x := x - 1
end

```

Suppose that we execute this statement with $x = 0$. Afterwards, is $x = 9$ or is $x = 10$? A language designer must consider such possibilities and specify exactly how the program will behave in each case. This is the hardest part of language design. It is quite easy to specify the *syntax* rules of a language, but is it much more difficult to specify the complete *semantics*.

The language which Dijkstra uses in his book *A Discipline of Programming* (Prentice-Hall, 1976) has a statement resembling the case statement with Boolean labels used above, although he uses different keywords and punctuation. Dijkstra uses a similar statement for loops: the entire statement is executed repeatedly until none of the guards is true.

Case statements tend to be lengthy, and it is tempting to try to abbreviate them. Faught proposes statements of (roughly) the following form:

```

case x of
  < 0 : s1;
  = 0 : s2;
  > 0 : s3
end

```

This is not general enough for all applications. For instance, it is difficult to see how Ackermann's function would be coded. There are, however, many situations in which each arm of an if or case statement makes an assignment to the same variable. In ALGOL 60, a statement has a value, and in places where other languages require a statement, ALGOL 60 allows an expression. Thus in ALGOL 60 we can write Ackermann's function in this way:

```

a :=
  if m = 0
  then n + 1
  else if n = 0
  then a(m-1,1)
  else a(m-1,a(m,n-1))

```

When ALGOL 60 was designed, many computers had only one arithmetic register, usually called the accumulator. A high level language compiler compiling one statement at a time would not usually, in the current statement, use the value left in the accumulator by the previous statement. The ALGOL convention was intended to get around this potential inefficiency by allowing a statement to have a value, the value being that left in the accumulator after the statement was executed.

This idea was carried over to ALGOL 68, which also has a case statement. It is less flexible than the case statements described above because there are no case labels. Instead, the introductory clause "case m in" is followed by n statements, and if $1 \leq m \leq n$, the m th statement is executed.

Thus, the ALGOL 68 case statement is very similar to the FORTRAN computed GOTO statement. Although the lack of case labels makes the ALGOL 68 case statement rather weak and sometimes hard to read, it does enable the compact expression of some algorithms. As in ALGOL 60, an expression may be used where a statement is expected. The algorithm for determining the number of days in a month can be expressed in ALGOL 68 in the following way:

```

days :=
  case month in
    31,
    if year mod 4 = 0
    then 29
    else 28
  fi,
  31,30,31,30,31,31,30,31,30,31
  esac

```

Most languages since the mid sixties have a case statement of one kind or another. For a fuller description of the use of case statements in various languages, read the paper "Notes on the case Statement" by C Wrangle Barth, in *Software: Practice and Experience*, volume 4, #3, 1974, pages 289 thru 298. ■

MICROTEK OUTPERFORMS ANADIX



CHECK THE CHART

SEE PAGE 19

“Quality Hardware Deserves Quality Software...”

**alpha
micro** + **datalab** = **QUALITY
SYSTEM**
**AM-100™
COMPUTER** + **WORD
PROCESSING
PACKAGE**

WORD-PROCESSING (EDITIT™ & FORMIT™)

- ★ Right and left margin justification (word wraparound) by space fill or true proportional spacing of characters on Diablo, Qume & NEC printers. Accommodates forced spacing.
- ★ Displays text on compatible terminal as it will appear on printer, including boldface and underlining.
- ★ Displays or prints any selected page or entire file – continuously or page at a time.
- ★ Form letter processing with prompting for input from terminal and/or up to ten external files. Use pre-searched and pre-sorted mailing lists, include unique responses, use separate or interleaved printing of addresses on envelopes, insert date, etc.
- ★ Size of file limited only by capacity of disk.
- ★ Unlimited move and copy of any portion of file to any or multiple places.
- ★ Obtain directory of all files in any account and display contents of any external file, all while in the editor.
- ★ Read any external file in any account or device, and write into any location.
- ★ Edit any file, with or without line numbers.
- ★ Automatically locate any point in any file.
- ★ Find the next occurrence, prior occurrences, subsequent occurrences or all occurrences of any string. Substitute any or all found strings with new strings.
- ★ Delete or insert any number of characters, words, lines or pages anywhere.
- ★ Complete descriptive help on all word processing commands within the editor and AMOS™
- ★ Powerful single-stroke “Alter” sub-editor. Provides single line, selected lines or global controls: positions cursor forwards or backwards; finds, replaces, inserts or deletes one or more characters; extends line; deletes to character(s).
- ★ Global editing control of selected columns.
- ★ Back-up files created automatically; Quit command restores files to prior version.
- ★ Automatic special numbering of BASIC programs and automatic submission of .BAS files to the BASIC compiler, .MAC files to the AMOS™ assembler, .TXT files to FORMIT™ and .TXT/m files to TXTFMT. Files edited with VUE can also be formatted with FORMIT™.
- ★ Renumber any numbered file with any increment.
- ★ Beep the terminal any number of times at the end of any single or queued operation(s).
- ★ Automatic paragraph recognition by user-definable indentation, automatic optional paragraph line feed, automatic paragraph indentation of any degree, including none and *negative indentation*.
- ★ Automatic page numbering with full control: upper or lower case Roman or Arabic numerals; top, bottom, center, right, left or alternating.
- ★ Up to six independent headers per page.
- ★ Automatic placement of any text at extreme right, left or center.
- ★ Control page width, length and line spacing.
- ★ Subscript, superscript, underline and boldface – together or in any combination.
- ★ Written in Assembler: shareable, re-entrant and fast.
- ★ Thoroughly tested, no known bugs.
- ★ No control character dependence. Self-evident command words may be abbreviated.
- ★ Extremely fast & easy to learn and use.

Documentation

Five separate manuals, combined in a durable 22 ring loose-leaf binder. Over 150 pages. Manuals include tables of contents, indexes, cross-referencing and summaries.

USER'S GUIDE: Detailed, simple instructions for AMOS™ and datalab commands used by people who are not programmers or system operators.

EDITIT™: Documentation for use of Version 2.0.
FORMIT™: Documentation for use of Version 2.0.

TRYIT: A self-instructional manual to teach a novice how to prepare, modify and variously format a letter. In less than one hour, anyone can use the Alpha Micro system productively.

OPERATORS GUIDE: Gives full instruction for installing the complete package, using the special operator functions in new utilities, and writing drivers for special printers.

AMOS and AM-100 are trademarks of Alpha Microsystems.

Selected New Utilities

- Restrict any program to operator access only.
- Request log-in automatically.
- Display operator-definable messages at log-in and/or log-off.
- View any file in blocks of defined number of lines; continue with scroll or screen clear.
- Receive, check and send mail to accounts of one or more users with menu-driven program.
- Users may send messages of any length to other jobs; operators may send messages to all jobs.
- List all major HELP files and display any selected major or secondary HELP file under screen oriented page control.
- Obtain understandable table giving status of user and operator jobs, and number of total, free and used blocks on each defined device.
- Many other functions.

MONEY-BACK GUARANTEE ON DOCUMENTATION

COMPLETE PACKAGE: \$250.
Documentation and all programs

Documentation Alone: \$50.

Money back guarantee if returned undamaged.

Copyright © 1979 datalab inc.

To order, contact your local dealer or call collect: 313-995-0663...Or write:

datalab
inc.

1221 Minglewood
Ann Arbor, Michigan 48103 U.S.A.

NEW!

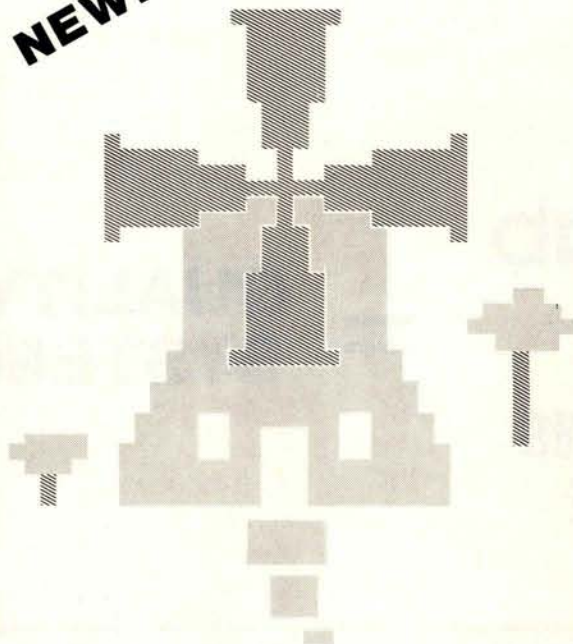

Introduction to Low Resolution

GRAPHICS

Now you can produce amazing computer graphics — even if you can't draw a straight line. Literally! Learn how to draw lines and shapes, make graphs, draw pictures and even do animations. The simple secrets of how to do all this are contained in SCLEBI's new book "Introduction to Low Resolution Graphics."

Today's exciting personal and small business computing machines are generally provided with at least some kind of "low resolution" graphics capability. What is low resolution graphics? It is graphics presented on a point-by-point basis where the number of points is limited to about 8000 or less. The APPLE II by APPLE Computers, Inc., the Radio Shack TRS-80 and the Commodore PET all have low resolution graphics capability. So do many other kinds of microcomputers.

What can you do with low resolution graphics? Lots of things . . .

If you know how! You can plot plain and simple or fancy and complex graphs to consolidate data, for business or pleasure purposes. But you can do so much more than that! You can use the capability to improve the presentation and impact of almost anything you want your computer to tell people. It can be used to animate games or data, clarify and amplify educational materials, or just plain entertain people. Get started putting your computer to new and exciting uses through the world of graphics. Anyone can learn and apply these easy-to-understand techniques. Order your copy today!

Shows How to Draw

- Straight lines
- Triangles
- Circles
- Ellipses
- Borders
- Reverse backgrounds
- Deck of playing cards
- A clown that winks
- Football grid
- Animated football game

In addition to these fundamentals of drawing and animation, the book tells how to synchronize computer-generated sounds to your illustrations.

\$9.95 □ No. 65 (use coupon on facing page)

NEW!

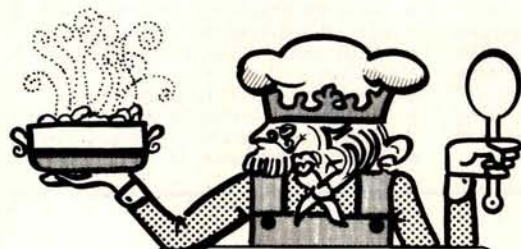

Put Together
Your Own Z80 Programs
Using These
Time-Tested Recipes

- Utility Routines —
- Stack Operations —
- Search and Sort Routines —
- Floating Point Routines —
- Z80 Instruction Set —
- And More —

Z80 Software Gourmet Guide & Cookbook

You need this cookbook!

You'll be able to put together programs without having to start from scratch. You'll have the most useful routines at your command — already programmed and ready-to-use. You'll get a plain-talk explanation of how the powerful Z80 instruction set works. And that's a big value to everyone, Z80 owner or not!

Why is it called a cookbook!

Because it's a book of recipes. It contains routines, subroutines and short programs. These are the ingredients. All you do is take a pinch of this, a pinch of that. Combine the ingredients, and voila — your own masterpiece! Just the program to suit your taste.

Time tested recipes.

Check These Features

- Handy reference to Z80 instruction set
- Search and sort routines
- Many general purpose utility routines
- Flow charts and source listings
- I/O and interrupt programming
- Machine codes given in both hexadecimal and octal notation
- How to control and manipulate Z80 stack
- Code and numeric conversion routines

Although the Z80 cookbook is brand new, SCLEBI's software cookbook idea has been around for years. The recipes are really time tested! Tens of thousands of our 6800 and 8080 cookbooks have been used throughout the U.S. and in countries around the world. Add the "Z80 Software Gourmet Guide & Cookbook" to your recipe filebox. Order today!

\$14.95 □ No. 75 (use coupon on facing page)



**SCELBI
Publications**



**Z80
Instruction
Handbook**

A complete guide to the Z80 instruction set. Machine codes presented in both octal and hexadecimal format. An index lists instructions alpha-

betically along with machine codes and timing information. Industry-standard mnemonics used throughout.

\$4.95* No. 20

**HOT TO TROT...
FOR COMPUTERS**



**Personal
Information
Management
System**

Plain talk on what a computer can do for you. How to use a computer without knowledge of programming. 15 examples include

personal mailing list, accounts payable — even an intelligent ham radio log. For the TRS-80, PET and others.

\$9.95* No. 10

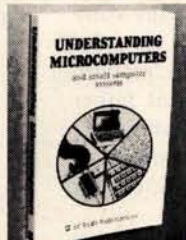

**Understanding
Microcomputers**

300-page no-nonsense easy-reading text. Simple-to-use glossary. Extra knowledge for reading and understanding computer magazines and manufacturer's literature. Instructions for microcomputers. Machine language programming. Input/output devices. Gives an intro to BASIC.

\$9.95* No. 90

**Calculating with
BASIC**

**Calculating
with BASIC**

A variety of programs to help the student, scientist, engineer, technician or hobbyist apply the language to practical problems. Covers

mathematics, finance and statistics, mechanical engineering and electronics. For fun Hangman and Space Capture games are provided.

\$7.95* No. 30

**MICRO
COMPUTER**



POTPOURRI

**Microcomputer
Potpourri**

Reference for beginner, technician, engineer. Glossary with all the jargon. Helps beginners understand computer magazines, mfg. literature and serves as refer-

ence for the pro. Reviews microprocessor chips in detail. Complete text on understanding microcomputers.

\$2.95* No. 70



SCELBI Publications, P. O. Box 3133, Milford, CT 06460 203-874-1573

*IMPORTANT ORDERING INFO! Include \$1.00 shipping/handling for each item. Prices shown are for North American customers. Master Charge, VISA, Postal and Bank Money Orders preferred. Personal checks delay shipping up to 4 weeks.

No. 10 No. 20 No. 30 No. 65 No. 70 No. 75 No. 90

Name (please print) _____

Card No. _____ Bank No. _____ Exp. _____

Address _____

City/State _____ Zip _____

Signature _____ Amt. Enc. _____

**See SCELBI books at your favorite
computer or electronics store.**

Some Laws of Personal Computing

Dr T G Lewis
Computer Science Department
Oregon State University
Corvallis OR 97331

The Origins of Personal Computing

In the beginning, man created pocket calculators to do rote arithmetic, eg: addition, subtraction, multiplication and division. Few people involved in the pocket calculator industry realized that pocket calculation was just the initial thrust into the "computing for the millions" consumer market. Indeed, the millions of dollars made by this computer consumer product helped to pay for the development of more sophisticated devices we now call personal computers.

Computing lacks a definite starting point. The works of Charles Babbage, and possibly Alan Turing, have little impact on daily computing (some will argue that these two pioneers have everything to do with modern computing, but I speak of practical rather than theoretical computing). So where are the fundamental theorems of computing? Is there a set of "equations of motion" for programming?

This article contains ten empirical observations, dubbed "laws of personal computing," that are derived from personal experience with personal computers in the real world of business. While many of the rules are controversial, I believe most can be proven to be true.

The first law of personal computing is of the form "action equals reaction." The law is derived by historical observation.

The first electronic computers were personal computers. That is, only a few programmers had access to the ENIAC, Whirlwind, and ATLAS. This arrangement faded rapidly in favor of batch operation and multiprogrammed operating systems. Clearly, the shift was the result of economic decisions. Large corporations poured large sums of money into data processing departments, and demanded efficiency in return. Military installations required security and performance as their return on investment. Batch operation satisfied their demands.

However, users (programmers mostly)

were soon able to show economics of scale and efficiency of operation by installing a limited form of interaction called *remote job entry*. Remote job entry moved rapidly into timesharing with terminals because this increases the man-machine interaction. Finally, we have come full circle to dispersed, stand alone, turnkey computers dedicated to a few users.

The key feature of the historical evolution of computing is "interactiveness." The more we can communicate with a computer system, the more we can enjoy using the system (within limits), and the more "personal" computing becomes. This leads to the first law of personal computing:

1. Personal computing equals interactive computing: the personalness of a computer system increases in direct proportion to its interactiveness.

The New Economics of Computing

Personal computing is governed by economics as much as by technology. Indeed, the directions taken by technology are governed by economics. Therefore, we must study economics in order to derive other laws of computing.

The concepts of programming, microprogramming, and integrated circuit design span the spectrum of software, firmware and hardware. Why is it more suitable to microprogram the IBM 370/168 (model 370 hardware, model 168 firmware) and not microprogram the Intel 8080? Where is the trade-off between an "expensive" system and an "inexpensive" system when all features of such a system are considered?

A system designer can choose to build a cheap processor (like the 8080, say) and save money on production, design, and maintenance of the cheap processor. The same designer can elect to build an expensive, sophisticated computer system and as a result increase the cost of hardware. Why construct an expensive computer? The

answer lies in looking at the total cost of a computer system. Let's take an example: the Intel 8080 requires that the HL registers be loaded each time a memory reference is made. This feature is simple to implement and saves hardware dollars. However, every program written for the 8080 must pay the price of this simplicity. Typically, a macro called HL is used to relieve the programmer of this chore. The Motorola 6800 includes a more sophisticated addressing mechanism using an index register for assisting in memory references. The addressability features of the 6800 often lead to 25 percent reduction in the number of instructions needed to perform the same function on the 8080. Both 6800 and 8080 architectures are more time consuming to program than the Texas Instruments 9900 chip due to the 9900's greater sophistication. Furthermore, the Microdata 32/S and Hewlett-Packard 3000 are stack machines supporting a high level language. Hence they are "easier" to program than any of the chips discussed above. But of course, the 32/S and 3000 are more expensive hardware machines than the chip machines.

Where is there a trade-off between complexity in hardware, complexity in firmware, and complexity in software? The trade-off is strictly economic, and leads to the second law of personal computing.

2. Conservation of agony: the work expended to program a computer to solve a problem plus the work expended to construct the computer system remains constant for that problem.

The second law of personal computing actually states that the problem solution remains at a constant level of complexity regardless of the system used to solve the problem.

The cost per unit of effort in building hardware may decrease (large scale integrated circuit (LSI) devices), and the cost of programming may increase (due to unsophisticated microcomputers). Therefore, in 1980, the most economical systems will be mainly firm hardware (due to its low cost) and a small share in software (due to the conservation of agony).

The results of the second law say something about the "power" of a computer system. Increasing speed or storage capacity increases power. Conversely, decreasing cost increases power of a personal computer. For example, the Intel 4040 (4 bit pocket calculator chip) increased personal computing power because it was cheap even though it was slow and had little storage capacity.

If we look at history once again, it is clear that an acceleration force is at work: increas-

ing capability leads to an increasing number of applications in which the computer can be useful. In turn, the increased use of computer systems in new applications results in increased sales. The sales stimulate mass production and further cost reductions. The result is to decrease the unit cost of the computer system.

We can demonstrate this counter intuitive notion as follows. In the mid-1960s, processor speed increased dramatically. This encouraged timesharing of the central proc-

WE'D LIKE TO SHARE A FEW WORDS WITH YOU...

modem / mō' dām / n: A device for transmission of digital information via an analog channel such as a telephone circuit.

Micromodem II* / mī' krō•mō' dām tū / trademark — a complete data communications system for the Apple II** Personal Computer, combining functions which formerly required a modem, an automatic calling unit, and serial and parallel interfaces. Onboard ROM firmware provides for remote console, terminal mode, and simplified implementation of more sophisticated applications with BASIC programs. The Micromodem II comes with the FCC registered Microcoupler, operates at 110 or 300 baud (Bell 103 compatible), and can automatically dial or answer the phone and transfer data.



Micromodem 100* / mī' krō•mō' dām wun hun' drād / trademark — a complete data communications system for S-100 microcomputers, providing all the capabilities of a serial interface card and an acoustic coupler, with the addition of programmable automatic dialing and answer. The Micromodem 100 comes with the Microcoupler and is fully S-100 bus compatible including 16-bit machines and 4 MHz processors. The Micromodem 100 operates at either of two software selectable baud rates — 300 baud and a jumper selectable speed from 45 to 300 baud.



acoustic coupler / ə•kūs' tik kup' lər / n: A modem that works through the standard telephone handset, transmitting data through the regular earphone and microphone. It can be affected by room noise and suffers from the distortion inherent in the carbon microphone.

Microcoupler* / mī' krō•kup' lər / trademark — an FCC registered device that provides direct access to the telephone system without the losses or distortions associated with acoustic couplers and without a telephone company supplied data access arrangement.

D.C. HAYES ASSOCIATES, INC. MICROCOMPUTER PRODUCTS

10 Perimeter Park Dr. Atlanta, GA 30341 (404) 455-7663

* Micromodem II, Micromodem 100, and Microcoupler are trademarks of D.C. Hayes Associates, Inc.
** Registered trademark of Apple Computer, Inc.

essor. The support of many terminals reduced both the cost per terminal and the cost of the unit of computation.

In the 1970s, the storage capacity has been increasing dramatically. There is a surge of activity in data base applications and a corresponding decrease in cost of storage. In short, we are witnessing the third law of personal computing in action:

3. As the power of a personal computer increases, its price decreases.

The third law deals only with hardware capability. Earlier we stated that hardware capability plays a decreasingly important role in personal computing. Indeed, the effects of the third law of personal computing are rapidly diminishing due to the fourth law:

4. Software is hard; hardware is soft: it is economically more feasible to build a computer than to program it.

It is economically easier to design, implement, and mass produce a machine like the Intel 8080 or IBM 360 than it is to design and implement an operating system, compiler, or sophisticated application program. The cost of a chip may run to \$250,000

when design and initial production are totaled. The cost of firmware BASIC may not exceed \$100,000 (many do, however), but the auxiliary costs of documents, service, training and marketing may exceed one million dollars.

A company contemplating a new hardware architecture is gravely penalized for making radical changes to the instruction set of their existing computer. Is it not to be expected that the IBM 370 is only an evolutionary departure from the IBM 360? Why is the Z80 processor nearly as successful in the market place as the 8080?

The high cost of programming as opposed to the cost of a chip is reversing the traditional roles of software and hardware. In the future, more emphasis will be placed on the software and less emphasis will be placed on the machine architecture. Indeed, much of the current software will become "hard," by being distributed in hardware read only memories as firmware.

One result of the fourth law is corollary A, which states the rule that governs pocket calculators today:

- A. Programs and data should be shared, but hardware should be replicated.

The only item in a computer system that must be shared from a technological standpoint is data. Common access to information stored in a data base may be logically justified by an application. Whether the access is done by timesharing or by dispersed processors is immaterial. Also, whether the data is copied for transmission, or the program that intends to process the data is copied for transmission to the data base machine is again immaterial.

The computer business has been overly enthusiastic about timesharing in the past. We must recall that timesharing was invented to lower the cost of hardware. Now that hardware is no longer the major cost item in a system, timesharing is not justifiable in most cases. In fact, I believe that timesharing failed. It failed because people couldn't understand it. Only computer experts are able to use MULTICS, VM/370 and other extremely capable timesharing systems. The average person will not tolerate JCL, telephone lines, computer jargon, and unreliable central computers that lose their files. In short, timeshared computers are hampered by their prerequisite of knowledge.

The computer utility concept of the late 1960s failed because of the lack of expertise on the part of the users. The high level of sophistication needed to use a utility doomed it to failure. It also put a bad name on personal computers.

CHECKS IN MICRO- QUANTITIES? NOW THERE'S A WAY.

Wondering how to use your micro to print checks for personal and business use? Now, from ARIES, there is a way to do it easily with **continuous checks in small quantities**. And, without a huge investment.

Micro check printing eliminates time consuming, error-prone hand-writing of PERSONAL, PAYROLL, or ACCOUNTS PAYABLE checks. For home or small business use, it's an idea whose time has come: A new way to make your micro pay off.

NOW AVAILABLE FROM ARIES:

PERSONAL CHECKS

8½" width
(7½" without margins)
3½" depth
200 @ \$39.00
500 @ \$79.00

BUSINESS CHECKS

8½" width
(7½" without margins)
7" depth (includes 3½" voucher, 3½" check)
200 @ \$48.00
500 @ \$95.50

Use for either Payroll or Accounts Payable

Includes imprinting of payer at upper left of check—4 lines of 30 positions each; bank name and address, transit and routing numbers; and the M.I.C.R. encoding at the bottom.

Brochure and Samples Available Upon Request. Prices Good Thru 1979.

Include BANK M.I.C.R. Encoding Sheet With Order.

**NO ONE ELSE OFFERS MICRO CHECK-
PRINTING SO EASILY. WITH ARIES
YOUR MICRO PAYS OFF.**

ARIES Computer Products
P.O. Box 7932B Eugene OR 97401
Price include freight anywhere in Continental U.S.

In effect, the "guilt by association" syndrome plagues personal computing today. Myths (it's too complicated), training (what is a byte?), and service (how do I get statements printed?) are three of the remnants of the computer utility that have turned people away from computing.

We can now state a conclusion called the fifth law of personal computing:

5. Knowledge costs more than software and hardware: the usefulness of personal computers increases in inverse proportion to how much people must know in order to use them.

The lesson is clear: any consumer product that is successful must be simple. The pocket calculators that solve known problems (arithmetic) are successful. The pocket calculators that solve unknown or unrecognized problems are failures.

The facts of life are even more severe for computers sold to the consumer market. The final economic law succinctly summarizes the fickle buyer's attitude:

6. The color, shape and size of a personal computer are often more important to a buyer than what is inside of it.

Once the personal computer system overcomes all other economic obstacles, it must be packaged and maintained by a reputable service organization. This means that all unnecessary buttons, switches and knobs must be eliminated. The manuals must reduce jargon and the software must be tailored to a particular industry.

The WH89 system by Heath, the C4P by OSI, the Apple II, the Commodore PET and the Radio Shack TRS-80 are all vivid examples of packaging in the personal computer hobby market. Datapoint, Wangco, and Basic-Four demonstrate the law with tailored software packages for small businesses.

Service fills the gap between the user's knowledge and the personal computer's lack of capability. Service rescues the user when the personal computer cannot repair itself. It is service that counts when the manuals do a poor job of explaining a feature of the system. Finally, service is performed by humans, and so far, humans understand other humans better than they understand a machine.

We can now turn to some interesting examples that lead to the final laws of personal computing. In particular, these laws affect the majority of computer experts engaged in applications implementation.

Implications of Interactiveness

The first law of personal computing equates "interactiveness" with "personalness." That is, in order to achieve a high degree of interactive computing, the personal computers of the future must be oriented toward languages and systems with a high degree of interpretation. Compiler languages, for example, have been shown to

The people who know more about acoustic couplers know why you should buy Datec.

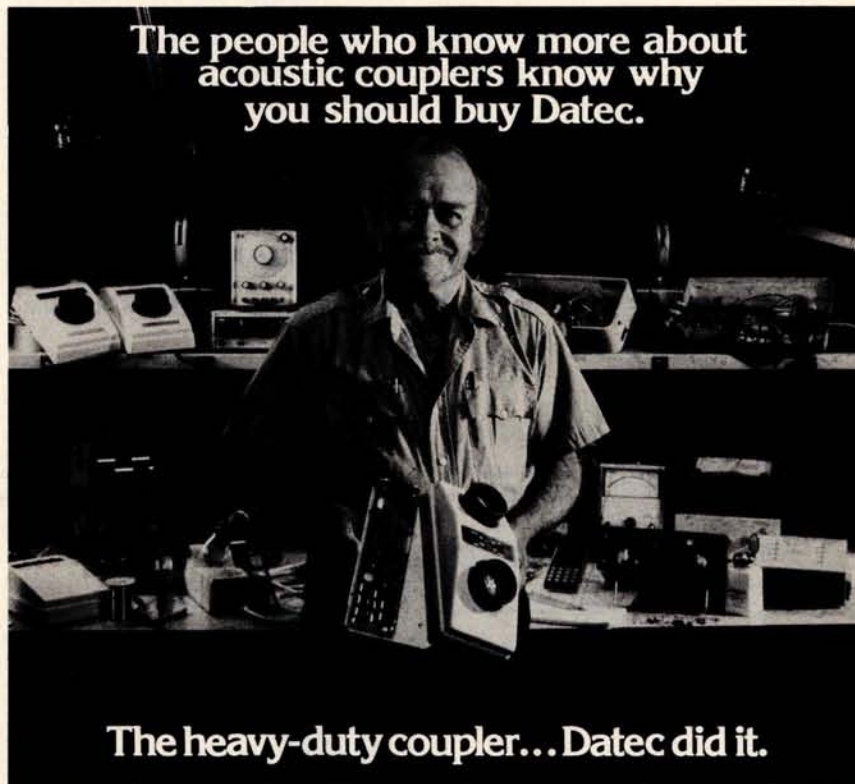

The heavy-duty coupler... Datec did it.

There is a reason so many Datec customers are communication line technicians, computer engineers and data processing experts. They recommend Datec for the simple, solid state, rugged design that has proven to be more reliable than bigger name couplers.

Acoustic couplers are the work horses of a data communications system. They should work every time, every day, so that you can install them and then forget them.

No wonder communication line technicians have nicknamed the Datec 32 the "heavy duty" acoustic coupler.

CRYSTAL CONTROL

Crystal controlled transmitter and receiver insures long-term stability and reliability, even in the most unfriendly operating environment.



This process reduces the probability of field failure below 2% for the first 1000 hours of operation. We find the faulty one before we ship it.

BIG EARS

Rugged, tight-fitting rubber cups effectively seal out vibration and room noise. They aren't beautiful, but they work.

TALKS WHEN IT RAINS



Datec couplers are highly sensitive, operating at received levels of -55dBm or lower. Our sensitive receiver can pull weak signals out of the "mud" of leaky, rain-soaked telephone cables.

GUARANTEED

Remove a few screws and the PC board pops out. It couldn't be simpler. Any problems incurred through normal use, and it's replaced or repaired free with no questions asked during the first year.

READILY AVAILABLE

Datec 300 bps acoustic couplers are readily available in both originate and originate/answer models. All Datec equipment including the new Datec 212 is Bell compatible. OEM inquiries are welcome.

DATEC INC., 300 E. MAIN ST., CARRBORO, NC 27510. (919) 929-2135

DATEC DID IT! Quality—designed in, burned-in, and guaranteed.

DATEC™

require from three to ten times as much effort in implementing a given program as an interpreter would require.

It is little wonder that BASIC has achieved the title "language of the masses." It is a simple interpretive language, easy to implement on a modest processor. Unfortunately, it is extremely inappropriate for major applications requiring typical business data processing.

7. BASIC is to personal computing as sign language is to English.

BASIC programs are easy to write, but difficult to understand, and provide inadequate control of a personal computer system. Few dialects of BASIC permit indentation, structuring, comments (without memory penalty), or error control and recovery. Here are a few objections to BASIC as a serious, professional implementation language.

- a. Poor error recovery facilities, eg: the application program must be capable of detecting file access errors, etc, and then calling an exception handling routine.
- b. No dynamic overlapping or memory mapping of programs too large to fit in main memory.
- c. Restricted data structures, eg: no pro-

visions for linked lists, trees, dynamic memory allocation for data, mixed data types.

- d. Limited user prompting, eg: forms handling, cursor control, scrolling and audio signals are lacking.
- e. Inadequate software security and protection, eg: no file security locks, interlock mechanisms for shared files, or source code shielding.
- f. Slow execution due to poor interpretation.
- g. Inadequate primitives for standard data processing, eg: no sorting, file access constructs, forms handling for report generation, or communications access constructs.

In short, BASIC is useful in the development of small programs for unsophisticated applications, or for programs that will be thrown away rather than modified.

The area of system control is no better off than the system languages area of personal computing. At least BASIC is partially standardized and widely known. Operating systems, on the other hand, have no consistent basis to begin with. Indeed, we question the utility of an operating system in interactive computing. This is pointed out in the eighth law:

8. An operating system is a feeble attempt to include what was overlooked in the design of a programming language.

This heretical notion is fully obvious in systems employing interpretive BASIC to the hilt. The Wangco, Tektronix 4051, and similar small scale interpretive BASIC systems have no visible operating system. All commands normally associated in traditional operating systems are put into extended BASIC in these personal computers. In general, interpretive systems (and thus interactive systems) have no need for an operating system.

In future personal computers, it is likely that a network of loosely coupled processors will communicate data and programs to one another. In such a network concurrent processes will be allowed and will often compete for limited resources. In this situation the synchronizing primitives of today's operating systems will migrate to hardware (or firmware) and not be of concern to the language interpreter.

The Ultimate Laws

We have covered the motivations for personal computing and have stated eight laws along the way. In the final analysis we can derive two ultimate laws of computing used (knowingly or otherwise) by computer

Discover why hundreds of PDP-11 users have turned to us for Pascal.



They're in process control. In data base management. In education, research and communications. Running on LSI-11's, PDP-11/70's and everything in between. RSTS/E, RT11, RSX or IAS — it makes no difference, they praise our Pascal.

Because they all have one thing in common. A desire to get more from their PDP-11 than another language — or another Pascal — can provide.

We've captured the elegance of Pascal in a real world compiler. It converses directly in machine language, giving remarkable execution speed and efficient memory use. It features straight-forward

program structure, uncluttered syntax, and other advantages of full standard Pascal.

But there's more, in the form of real-time extensions. 15 digit (double precision) arithmetic. In-line assembly code. I/O hardware access. FORTRAN interface. Direct-access files. Overlays. Plus others. There's even an interactive symbolic debugger.

Reliability? Introduced in 1975, we're at over 400 sites now. We guarantee stated performance and provide 1 year of follow-up support. Give us a call; we have a demo library, manuals, and benchmark, ready for your inspection.

Oregon
minicomputer
Software inc.

2340 SW Canyon Road
Portland, Oregon 97201
(503) 226-7760
TWX 910-464-4779

PDP-11, LSI-11, PDP-11/70, RSTS/E, RT11, RSX, and IAS are trademarks of Digital Equipment Corporation

Distributors:

Australia: Sydney; Network Computer Services, 290 3677
Canada: Vancouver; Valley Software, (604) 524-9741
England: Stafford; Hours Computing Ltd, 0785 44221
Japan: Tokyo; Rikei Corporation, 03-345-1411

manufacturers:

9. The ultimate personal computer is a robot: the goal of personal computing is to reduce the differences between humans and computers.

In effect we are striving to make personal computers do what people can do, but faster, more accurately, and cheaper. We seek a partnership with personal computers akin to the symbiosis between humans and household pets.

A faster personal computer allows us to process census information in two or three years instead of 15 years. Speed is essential in a lunar landing, and so is accuracy. An air traffic control computer is much more accurate than a human operator. The result is safer air transportation for people.

10. Knowledge is power: information is the fabric of knowledge; the controller of information wields power.

While personal computers are fast, accurate and cheap, they also cause high speed propagation of errors, speed of light crime, and sometimes loss of life when they fail.

Politicians are able to push a button and disseminate campaign propaganda to the millions. Factories can replace entire vocations by automating production. Financial insti-

tutions are at the mercy of their data processing centers.

The laws of personal computing are not only important to computer scientists, but also to society as a whole. Perhaps there is a place today for the futurist, the philosopher of computer science. ■

Improve Your Lot.

Is there room for a little improvement around your lot?

Like landscaping in the front yard? A big pool in the back? Maybe another bedroom if you have a lot of "little ones"?

Whatever your home needs, United States Savings Bonds can make improvement a lot easier. All you have to do is join the Payroll Savings Plan. That way, a little piece of each paycheck is set aside to buy Bonds. Automatically.

In a little while, you'll have a lot of Bonds piled up. And that means a lot of savings.

So join the Payroll Savings Plan. Buy United States Savings Bonds.

And do a little for your lot.



AM A public service of this publication and The Advertising Council.

Volunteer Agency: Leo Burnett Company, Volunteer Coordinator: John T. Landry, Philip Morris U. S. A.

**The Public Service Campaign sponsored by
THE MAGAZINE PUBLISHERS ASSOCIATION**

G. W. COMPUTERS LTD.

This is how your business appears on the screen

Approximately 60-100 entries/inputs require only 2-4 hours weekly and your entire business is under control.

*PROGRAMS ARE INTEGRATED —

- 01 = ENTER NAMES/ADDRESS, ETC
- 02 = *ENTER/PRINT INVOICES
- 03 = *ENTER PURCHASES
- 04 = *ENTER A/C RECEIVABLES
- 05 = *ENTER A/C PAYABLES
- 06 = ENTER/UPDATE INVENTORY
- 07 = ENTER/UPDATE ORDERS
- 08 = ENTER/UPDATE BANKS
- 09 = EXAMINE/MONITOR SALES LEDGER
- 10 = EXAMINE/MONITOR PURCHASE LEDGER
- 11 = EXAMINE/PRINT INCOMPLETE RECORDS
- 12 = EXAMINE PRODUCT SALES

SELECT FUNCTION BY NUMBER

- 13 = PRINT CUSTOMER STATEMENT
- 14 = PRINT SUPPLIER STATEMENTS
- 15 = PRINT AGENT STATEMENTS
- 16 = PRINT TAX STATEMENTS
- 17 = PRINT WEEK/MONTH SALES
- 18 = PRINT WEEK/MONTH PURCHASES
- 19 = PRINT YEAR AUDIT
- 20 = PRINT PROFIT/LOSS ACCOUNT
- 21 = UPDATE END MONTH FILES
- 22 = PRINT CASH FLOW FORECAST
- 23 = ENTER/UPDATE PAYROLL (NOT YET AVAILABLE)
- 24 = RETURN TO BASIC

WHICH ONE? (ENTER 1-24)

Each program goes to sub menu, e.g.:

- (9) allows: A, LIST ALL SALES; B, MONITOR SALES BY STOCK CODES;
C, RETRIEVE INVOICE DETAILS; D, AMEND LEDGER FILES;
E, LIST TOTAL ALL SALES.

Think of the possibilities and add to those here if you wish.

Price for current package Version 1 is \$550, or Version 2 (including aged debtors analysis, etc.) is \$750, or full listing, \$300.

PET 16/32K disk-based version, SWTP 6800, IMS/CPM/Z80/S-100. Compatible systems shortly available for Apple and Tandy.

Contact: **Tony Winter on 01-636-8210**
89 Bedford Court Mansions
Bedford Avenue
London W1, UK



Ah! MICAH . . .
Satisfyin' Software
 that turns your system on!

EXPAND

Your CP/M to run
CROMEMCO SOFTWARE!

MICAH's worldwide bestseller. A powerful tool to expand your CP/M system to be compatible with Cromemco Software. (BASIC, FORTRAN, COBOL, DBMS, WPS, etc.) Specify: system configuration/memory size. 5" or 8" Disk w/manual: \$95.00

OSBORNE BUSINESS SOFTWARE in 16K BASIC and CBASIC2. Now available: Payroll, A/R and A/P. CP/M or Cromemco compatible. Specify your system. Coming soon: G/L.

ea.: \$95.00

- MICROPLOT (Versatile Printer Graphics)
- DBMS conversion to NAD (for Cromemco)
- SPOOLER (for Cromemco)
- CBIOS (CP/M for Cromemco)
- DUPE (Disk Utility Package)
- WINNING BLACKJACK (for CP/M)

• Call or write for more information and prices •
 • credit cards accepted •

MICRO Applications and Hardware
 CONSULTANTS and SOFTWARE DEVELOPERS
MICAH • Box 22212 • San Francisco, CA 94122 • 415/664-0778 or 564-4495

Retro-Graphics™



For your Dumb Terminal. The Retro-Graphics PC card mounts easily in the Lear Siegler ADM-3A to provide you with an affordable graphics computer terminal.

Features:

- Z-80 Based
- 512 by 250 Dot Matrix
- Simple Plug-in Interconnect
- Point Plotting
- Automatic Vector Generation
- Optional TEKTRONIX Software Compatibility

You will be impressed with the packaging, performance and price of the Retro-Graphics card. Write or phone today for complete specifications.

DIGITAL ENGINEERING, INC.
 1787 Tribute Road, Suite K
 Sacramento, CA 95815
 (916) 920-5600

BYTE's Bits

Trees

Guy L Steele Jr, MIT Artificial Intelligence Lab,
 Massachusetts Institute of Technology, Cambridge MA 02139

I think that I shall never see
 A matrix lovely as a tree.
 Trees are fifty times as fun
 As structures a la PL/I
 (Which Dijkstra claims are too baroque).
 And SNOBOL's strings just can't compare
 With all the leaves a tree may bear,
 And COMMIT strings are just a joke.
 Vectors, tuples too, are nice,
 But haven't the impressive flair
 Of trees to which a LISP is heir.
 A LISPer's life is paradise!

Many people think that JOSS
 And others, too, are strictly boss;
 And there are many BASIC fans
 Who think their favorite language spans
 All that would a user please.
 Compared to LISP they're all a loss,
 For none of them gives all the ease
 With which a LISP builds moby trees.

RPG is just a nurd
 (As you no doubt have often heard);
 The record layouts are absurd,
 And numbers packed in decimal form
 Will never fit a base-two word
 Without a veritable storm
 Of gross conversions fro and to
 With them arithmetic to do.
 And one must allocate the field
 Correct arithmetic to yield
 And decimal places represent
 Truncation loss to circumvent:
 Thus RPG is second-rate.
 In LISP one needn't allocate
 (That boon alone is heaven-sent!)
 The scheme is sheer simplicity:
 A number's just another tree.
 When numbers threaten overflow
 LISP makes the number tree to grow,
 Extending its significance
 With classic tree-like elegance.
 A LISP can generate reports,
 Create a file, do chains and sorts;
 But one thing you will never see
 Is moby trees in RPG.

One thing the average language lacks
 Is programmed use of push-down stacks.
 But LISP provides this feature free:
 A stack — you guessed it — is a tree.
 An empty stack is simply NIL.
 In order, then, the stack to fill
 A CONS will push things on the top;

To empty it, a CDR will
 Behave exactly like a pop.
 A simple CAR will get you back
 The last thing you pushed on the stack;
 An empty stack's detectable
 By testing with the function NULL.
 Thus even should a LISPer lose
 With PROGs and GOs, RETURNs and DOs,
 He need his mind not overtax
 To implement recursive hacks:
 He'll utilize this clever ruse
 Of using trees as moby stacks.
 Some claim this method is too slow
 Because it uses CONS so much
 And thus requires the GC touch;
 It has one big advantage, though:
 You needn't fear of overflow.
 Since LISP allows its trees to grow,
 Stacks can to any limits go.

COBOL input is a shame:
 The implementors play a game
 That no two versions are the same.
 And rocky is the FORTRAN road
 One's alpha input to decode:
 The FORMAT statement is to blame,
 But on the user falls the load.
 And FOCAL input's just a farce;
 But all LISP input comes pre-parsed!
 (The input reader gets its fame
 By getting storage for each node
 From lists of free words scattered sparse.
 Its parses all the input strings
 With aid of mystic mutterings;
 From dots and strange parentheses,
 From zeros, sevens, A's and Z's,
 Constructs, with magic reckonings,
 The pointers needed for its trees.
 It builds the trees with complex code
 With rubout processing bestowed;
 When typing errors do forebode
 The rubout makes recovery tame,
 And losers then will oft exclaim
 Their sanity to LISP is owed —
 To help these losers is LISP's aim.)

The flow-control of APL
 And OS data sets as well
 Are best described as tortured hell.
 For LISPer everything's a breeze;
 They neatly output all their trees
 With format-free parentheses
 And see their program logic best
 By how their lovely parens nest.
 While others are by GOs possessed,
 And WHILE-DO, CASE, and all the rest,
 The LISping hackers will prefer
 With COND their programs to invest
 And let their functions all recur
 When searching trees in maddened quest.

Expanding records of fixed size
 Will quickly programs paralyze.
 Though ISAM claims to be so wise
 In allocating overflow,
 Its data handling is too slow
 And finding it takes many tries.
 But any fool can plainly see
 Inherent flexibility
 In data structured as a tree.

SUPER SOFTWARE!

**MICROWARE 6800 SOFTWARE IS
 INNOVATION AND PERFORMANCE**

LISP Interpreter

The programming language LISP offers exciting new possibilities for microcomputer applications. A highly interactive interpreter that uses list-type data structures which are simultaneously data and executable instructions. LISP features an unusual structured, recursive function-oriented syntax. Widely used for processing, artificial intelligence, education, simulation symbolic, and computer-aided design. 6800 LISP requires a minimum of 12K RAM.

Price \$75.00

A/BASIC Compiler

The ever-growing A/BASIC family is threatening old-fashioned assembly language programming in a big way. This BASIC compiler generates pure, fast, efficient 6800 machine language from easy to write BASIC source programs. Uses ultra-fast integer math, extended string functions, boolean operators and real-time operations. Output is ROMable and RUNS WITHOUT ANY RUN-TIME PACKAGE. Disk versions have disk I/O statements and require 12K memory and host DOS. Cassette version runs in 8K and requires RT/68 operating system.

Price: Disk Extended Version 2.1 \$150.00

Cassette Version 1.0 \$65.00

A/BASIC Source Generator

An "add-on" option for A/BASIC Compiler disk versions that adds an extra third pass which generates a full assembly-language output listing AND assembly language source file. Uses original BASIC names and inserts BASIC source lines as comments. SSB and SWTPC Miniflex version available.

Price: \$75.00

A/BASIC Interpreter

Here it is—a super-fast A/BASIC interpreter that is source-compatible with our A/BASIC compiler! Now you can interactively edit, execute and debug A/BASIC programs with the ease of an interpreter—then compile to super efficient machine language. Also a superb stand-alone applications and control-oriented interpreter. Requires 8K RAM. The cassette version is perfect for Motorola D2 Kits.

Price: \$75.00

RT/68 Real Time Operating System

MIKBUG—compatible ROM that combines an improved monitor/debugger with a powerful multitasking real-time operating system. Supports up to 16 concurrent tasks at 8 priority levels plus real time clock and interrupt control. Thousands in use since 1976 handling all types of applications. Available on 6830 (MIKBUG-type) or 2708 (EPPROM-type) ROM. Manual is a classic on 6800 real-time applications and contains a full source program listing.

Price: RT68MX (6830) \$55.00

RT68MXP (2708) \$55.00

6800 CHESS

A challenging chess program for the 6800. Two selectable difficulty levels. Displays formatted chess board on standard terminals. Requires 8K memory. Machine language with A/BASIC source listing.

Price: \$50.00

Our software is available for most popular 6800 systems on cassette or diskette unless otherwise noted. Disk versions available on S.S.B., SWTPC, or Motorola MDOS. Please specify which you require. Phone orders are welcomed. We accept MASTERCHARGE and VISA. We try to ship orders within 24 hours of receipt. Please call or write if you require additional information or our free catalog. Microware software is available for OEM and custom applications.

MICROWARE
 SYSTEMS CORPORATION

P.O. BOX 4865
 DES MOINES, IA 50304
 (515) 265-6121

IMMEDIATE DELIVERY

Domestic & Export

DEC LSI -11 COMPONENTS

A full and complete line with software support available.

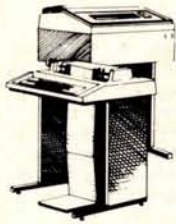

Mini Computer Suppliers, Inc.

25 CHATHAM ROAD
SUMMIT, NEW JERSEY 07901
SINCE 1973

(201) 277-6150 Telex 13-6476

Z_S - SYSTEMS



64K RAM BOARD

The Z_S-SYSTEMS 64K RAM board is designed to operate in any Z80 based microcomputer having S-100 bus. It uses 16K dynamic RAM chips, & features:

- Board select
- Bank select
- Transparent on-board refresh
- 2 or 4MHz operation (w/ no wait state)
- Memory disable

FLOPPY DISK CONTROLLER

Handles with no modification up to:

- * 4 standard 8" drives (Shugart or compatible) or
 - * 3 minidrives 5"
- Run with 2 or 4 MHz CPU

Compatible with Cromemco and M/PM multiuser. Fully assembled, burned in, & tested. Available from stock to 60 days

As low as \$500.00 in quantities of 100

Price of one \$695.00

With 16K RAM \$359.00
Plus shipping charges



Use CP/M Disk Operating System
Using the 1771 LSI controller
Price of one \$245.00
PC board only \$35.00

SEND FOR FREE INFORMATION

6 months warranty on our boards with normal use

Z_S-SYSTEMS

PO Box 1847, San Diego, CA 92112
(714) 447-3997

When all their efforts have gone sour
To swell fixed records, losers glower.
But list reclaimers hour by hour
By setting all the garbage free
Yield CONSequent capacity:
Thus trees indefinitely flower.
(And trees run on atomic power!)

To men of sensibility
The lesson here is plain to see:
Arrays are used by clods like me,
But only LISP can make a tree.

- The Great Quux (with apologies to Joyce Kilmer)
©Copyright 1973 Guy L Steele Jr All rights reserved.

How this poem came to be printed
Notes by C Helmers

The above parody was found on the MIT Artificial Intelligence Laboratory's computer during a recent (July 3) visit made to Henry Baker at the University of Rochester Computer Science Department. Its content reflects the LISP orientation of our August 1979 issue, and in a humorous way summarizes the true artificial intelligence hacker's point of view about LISP as a tool.

Henry dug up an electronic view of the poem on the computer and communicated by that means my desire to make it more widely available. The poem's author, it turns out, is Guy Steele, who is presently connected with the MIT Artificial Intelligence Laboratory. I had in fact spent some time talking with Guy on a previous occasion, not knowing anything at all about his penchant for poetic parody. The poem was written in 1973.

One of Guy's major technical accomplishments to date is his recent student project at MIT: design and implementation of a LISP-machine chip in silicon.

In his letter accompanying the poem, Guy points out that probably the most obscure piece of jargon is the word "moby" used as an adjective. The etymology is a reference to Melville's whale, Moby-Dick. Thus a "moby tree" is a tree which is figuratively as large as a whale, or gigantic. Most of the other terminology referring to LISP is covered in recent BYTE issues; the references to other languages such as JOSS, RPG, FORTRAN, FOCAL, APL, the OS operating system of IBM, etc are best left undefined for the purposes of the poem.

The import of the communications network as a tool for individual computer users is signified by the practical example provided in this poem's arrangement for use in BYTE. The file containing "Trees" was publicly available to any person signing onto the MIT-AI computer. Henry Baker in particular was able to sign onto the computer from his usual location in Rochester, NY via the Arpanet, an electronic network connecting many research computers. Henry then left a "mail" message via the network for Guy at Stanford, California, where Guy was spending the summer. Guy then got in touch with me at my office by phone (also electronic). The arrangement was concluded with transmission of a physical copy to BYTE via the postal service.

Readers of BYTE who own personal computers with an RS-232 interface will soon be able to sign up for private services equivalent to the electronic mail functions used by Henry and Guy in arranging this over the Arpanet. At least 2 different companies now offer (see recent advertisements) private off-hours timesharing and networking services at relatively low rates. These are typically billed via Master Charge and VISA. One of these services, Telecommunications Corporation of America, promises to offer a nationwide users' directory of identification numbers for its users, analogous to a phone directory. This arrival of individual-oriented digital communications-oriented networks will probably mark one of the great milestones of personal computing. ■

\$3,995

Million-Character Computer System One-Year Transferable Warranty

\$3,995

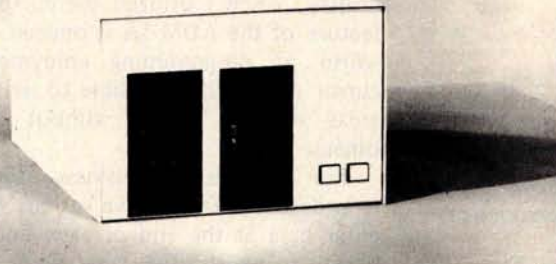

SEE System 6684 Unique Standard Features

- CPU integrated into Diskette Cabinet with peripheral ports in rear of cabinet
- 4 Full communications ports RS232 or 20 mA/60 mA CL; 75 to 19,200 bits/sec.

\$4,995

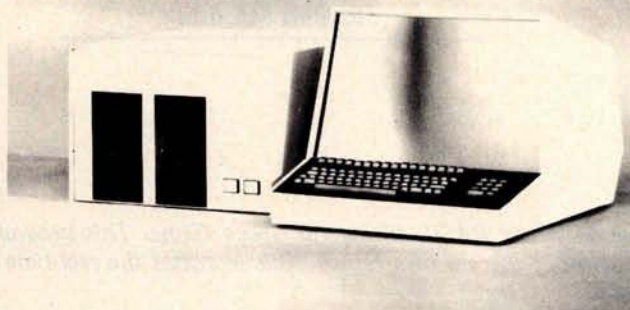

SEE System 6784 Unique Standard Features

- CPU integrated into video terminal cabinet with peripheral ports in rear
- Video has 16 programmable function keys, 128 high resolution characters with graphics, numeric keypad, reversed video, full editing, 24 x 80 display

Standard Features on All Systems

- Central Processing Unit with 12 slots; 2 MHz (expandable to 4MHz with pipelining architecture)
- 8 Free Slots for expansion; capacity for 442,368 characters of memory within standard chassis
- 49,152 characters of 200 ns random access memory; 150 ns memory optional
- 8 vectored interrupts; all input and output is interrupt driven
- 1.2 million characters, double sided, dual 8" diskettes, IBM 3470 compatible
- Printer controller; Centronics compatible
- Magnum BASIC. Extremely fast business BASIC with full editing capabilities, print using, sequential and random files, integer and floating point arithmetic with up to 16 digits precision; N-dimensional matrices and much more A superset of Microsoft 16K extended disk BASIC
- Interactive conversational macro assembler and editor for 6800 family microprocessors.
- One-year transferable limited warranty on parts and labor for all SEE hardware
- Guaranteed 24-hour turn-around time on repairs

Optional Features on All Systems

- Up to 64 interconnected, intelligent terminals with no degradation of response time. Each is a stand alone CPU. True distributed processing
- Expandable to 12 MB of 150 ns RAM for each terminal
- Up to 64 RS232 ports with full communications. Talks to any peripheral or CPU with RS232 interface
- Expandable to 4 MB of diskette storage
- Up to 660 MB hard disk storage with removable modules
- ANSI standard 10.5 inch tapes (1600 BPI)
- 11 MB cartridge tape system
- Matrix and word processing printers from 55 CPS to 1400 LPM
- Choice of 6809 and/or 6512 CPU board with speed of up to 4 MHz with 150 ns memory
- Interactive relocatable macro assembler, development system and DOS for 6502 and 6512 microprocessors. Can assemble source programs up to 2 MB long
- PASCAL compiler
- FORTRAN compiler
- BASIC compiler
- COBOL compiler
- Powerful word processing software
- Comprehensive business software, incl. General Ledger, Accounts Receivable, Accounts Payable, Inventory, Payroll; Packages for Physicians, Publishers, Manufacturers, etc.

Quantity discounts to bona fide dealers, OEMS, and schools
Special configurations and modular shipment available
A few distributorships available in the United States and other countries



SYSTEMS ENGINEERING ENTERPRISES

1749 Rockville Pike, Rockville, Maryland 20852
(301) 468-1822

Space Game

Loring C White
26 Boswell Rd
Reading MA 01867

Listing 1: Altair BASIC listing for Space Game. This program allows data entry without the use of a return. This increases the real-time appearance of the game.

```
10 PRINTCHR$(26)
20 Y5=5:GOSUB670
30 PRINT"YOU HAVE BEEN ASKED TO GO ON A MISSION TO DESTROY FIVE"
40 PRINT"ENEMY CRAFT THAT THREATEN THE GALAXY-----"
50 PRINT"YOU MUST POSITION YOUR CRAFT SO THAT THE ENEMY "
60 PRINT"IS IN POSITION IN THE CENTER OF YOUR GUN SIGHT IN ORDER"
70 PRINT"TO DESTROY THE ENEMY SPACECRAFT.
80 PRINT"THE AIMING IS DONE AS FOLLOWS:"
90 PRINT"HIT A 'U' FOR UP MOTION"
100 PRINT"HIT A 'D' FOR DOWN MOTION"
110 PRINT"HIT A 'L' FOR LEFT MOTION"
120 PRINT"HIT A 'R' FOR RIGHT MOTION"
130 PRINT"HIT A 'F' TO FIRE ROCKETS"
140 PRINT"HIT A 'CONTROL C' TO ABORT THE MISSION (CHICKEN OUT!)"
150 PRINT"THE ENEMY RETURN FIRE WILL GRADUALLY DESTROY YOUR AIMING
160 PRINT"ABILITY!!!!!! SO DON'T DELAY!!!!"
170 FORN=0TO15000:NEXT
180 INPUT"TYPE 'N' FOR NOVICE PILOT;'E' EXPERIENCED;'A' FOR 'ACE':";VS
190 IFVS="E"THENV8=150
200 IFVS="N"THENV8=300
210 IFVS="A"THENV8=75
220 PRINTCHR$(26)
230 Y5=10:X5=10:GOSUB670
240 PRINT"----GOOD LUCK ON YOUR MISSION --- ON INTO BATTLE!!!!"
250 FORN=0TO1000:NEXT
260 POKE3758,18:POKE4031,18
270 D2=1:D1=1:PRINTCHR$(26)
280 GOSUB1140
290 Y5=6:X5=0:GOSUB670:GOSUB500
300 Y5=INT(10*RND(1))+7)
310 X5=INT(20*RND(1))+21)
320 GOSUB670
330 GOSUB640
340 GOSUB690
350 GOSUB1080
360 IF(INP(16)AND1)=0THEN350
370 D=(INP(17)AND127)
380 GOSUB670
390 IFD=76THENX5=X5+1
400 IFD=82THENX5=X5-1
410 IFD=85THENY5=Y5+1
420 IFD=68THENY5=Y5-1
430 IFD=70THEN710
440 IFD=3THEN490
450 GOSUB1050
460 GOSUB670
470 GOSUB640
480 GOTO340
490 POKE3758,16:POKE4031,16:END
```

Listing 1 continued on page 198

If you don't have analog graphics capability but do have an 8080 computer with a video display such as the ADM-3A, you may find this program a real challenge.

For the past year or so I have been using the ADM-3A video monitor for running programs written for Teletype display, such as the early *Star Trek* games. Most of the new games are written with cursor control, giving a vast improvement to the display. When I utilized the cursor control feature of the ADM-3A it opened up a new world of programming enjoyment; with cursor control it is possible to write various areas on the screen without disturbing others.

For example, in business programming it is desirable to preserve various tables and enter data at the end of each line without having to rewrite the table every time new data is written. In card games such as blackjack, it is convenient to print out the various cards in a line from left to right and hold the display while other cards are being written on another part of the screen. This type of display is possible only with a terminal having cursor control. Most of the programs I have rewritten are much more pleasing in the cursor control format.

The program in listing 1 features capabilities not found in many of the space war games available commercially. It does not require a graphics or analog display terminal. In order to realize the full capabilities of the game it is necessary to have a 24 line by 80 character video monitor set for 9600 bps or faster, with a BASIC speaking computer. My system runs in MITS Altair, 16 K Extended BASIC, and the program itself will run in less than 4 K bytes of memory. MITS Altair 8 K Revision 3.2 BASIC can also be used and the program revisions are discussed below.

Program Features

Some of the features of the program are:

- The enemy craft takes evasive action during the run.
- There are three levels of difficulty: novice pilot, experienced pilot and ace.
- Final performance classification is displayed after each mission.
- Based on the skill of the pilot, the computer adjusts the degree of difficulty accordingly. Thus a novice can advance to experienced or ace by achieving a 75 percent record or better over a set time. Likewise a poor performance results in a down-



Without our super programs, you've got just another mild mannered computer.

Computer Custom Systems is proud to introduce the latest advance in computer programming for the TRS-80. Chained, link-listed and ring link-listed software that provides unmatched access time. These programs will turn your mild mannered TRS-80 into super computer.

Programs developed especially for the TRS-80 32K.

GENERAL LEDGER 2 disk minimum, 3 recommended
350 account members. 1600 transactions per data diskette. Open ended transactions. Trial balance, adjusted trial balance, balance sheet, income statements. Listings by data and account number. Maintenance program for entry of beginning balances\$200

ACCOUNTS RECEIVABLES* 2 disk minimum, 3 recommended
320 account numbers per data disk. Open ended transactions. Automatic aging 30, 60, 90+ days. Pay on account or pay selected invoice. Bill selected or all accounts. Listing of all or selected accounts keyed to subaccount numbers\$200

ACCOUNTS PAYABLE* 2 disk minimum, 3 recommended
320 account numbers per data disk. Open ended transactions per data disk. Variable percentage discount aging. Check writing. Listing of accounts\$200

PAYROLL* 2 disk minimum, 3 recommended
164 employees per data disk. Open ended number of employees. Gross, Net, FICA, FIT, and 10 user-defined deductions. Self generated W-2's and 941A's. Summaries for payday, monthly, quarterly and yearly. Salaried, hourly or commission sales or any combination\$175

INVENTORY* 2 disk minimum, 3 recommended
Retail inventory control for 960 items per data diskette. Open ended diskettes for more inventory items. Part number, item description, location, manufacturer, quantity on hand, on order, cost, minimum quantity on hand. Self generated orders when minimum quantity is reached\$175

JOB COSTS ANALYSIS* 2 disk minimum
Material costs, taxes, travel costs, special equipment, miscellaneous costs, sub-contractor expenses. Tie in with PAYROLL for labor costs\$175

CHECK REGISTER* 1 disk minimum.
Open ended check register to 32000 checks on up to 6 diskettes. Generated bank reconciliation statements. Retrieval of checks and information by date written, account number, check number, or several internal codes which are user defined. Replaces old hand operated systems\$100

*Optional tie in with GENERAL LEDGER.

MAIL LIST 2 disk minimum
500 listings per diskette. Name, Address, City, State, Zip, Phone Number, Selection code. Sorts by last name and zip code and prints mail labels. Optional tie in with WORD PROCESSOR\$125

WORD PROCESSING 1 disk minimum
Full upper and lower case characterization. Up to 3 pages of text in memory at a time. Store up to 30 pages of text per diskette. Load, Save, Print-out (single or multi-copies) Insert/Delete lines, characters, or blocks of text. Block Move/Delete/Copy lines. Typesetting and variable length page. Type in the text sloppy, clean it up on the screen and print out a perfect copy. Interfaces with Selectric II. Optional tie in with MAIL LIST. See special offer below\$150

COLUMN CALCULATOR 1 disk minimum
Statistical analysis of 1200 items of data with linear regression, histograms, and plotting of the results. All information can be manipulated by columns and rows; adding, subtracting, multiplying and dividing columns by other columns and putting the results in a third column\$80

DESIGNER PACKAGE 2 disk minimum
Index card file has now been computerized for quick access to information. 320 "cards" with 20 information items each with access to each card via any combination of the items listed. Up to 90 drawings per data diskette with instant retrieval for review, update or deletion. Open ended number of drawings and cards\$175

BUILDER III 3 disk minimum
Complete job cost analysis package for home builder. 189 user-defined cost categories. Automatic invoice control to actual cost of the home under construction. User input for estimated costs of home. Computer generated cost-to-cost comparisons. Up to 47 homes under construction per data diskette\$200

REAL ESTATE 1 disk minimum
Provides complete real estate analysis to assist you in the purchase of investment real estate. Calculates based on square feet, price, land value, rentals. Gross multiplier of rentals. Projected income expense statement. Debt service and financial calculations on a cost basis and in an inflationary economic climate. Plotting of rate of return and various other statistical analysis\$80

SPECIAL ONE-TIME OFFER

A combination of the WORD PROCESSOR and MAIL LIST. Type your letter once and the computer will automatically insert the name and address and personalize the letter to any extent that the user wants. The letter will be automatically typeset and printed out using the selection code built up with the MAIL LIST program or will be sent to all persons on the diskette. 2 disk minimum**ONLY \$75**

REAL ESTATE INVESTMENT PACKAGE

A combination of the WORD PROCESSOR, COLUMN CALCULATOR, DESIGNER PACKAGE, and a special MAIL LIST. Included with this package are the FINANCIAL REPORT program for up to 45 properties/data diskette and CAPITAL GAINS ANALYSIS program. 2 disk minimum**ONLY \$275**

To order the most advanced software for your TRS-80, select the program you desire and send your check or money order today. Or telephone and we'll charge it to your VISA or Master Charge.

Computer Custom Systems, Inc.

603 W. 13th St. Austin, Texas 78701 512 472-6168

Listing 1 continued from page 196:

```

500 PRINT*
510 PRINT*
520 PRINT*
530 PRINT*
540 PRINT*
550 PRINT*
560 PRINT*
570 PRINT*
580 PRINT*
590 PRINT*
600 PRINT*
610 PRINT*
620 PRINT*
630 RETURN
640 PRINT"1-O-1":
650 P=Y5:Q=X5
660 RETURN
670 PRINT CHR$(27)+"="+CHR$(32+Y5)+CHR$(32+X5):
680 RETURN
690 PRINTCHR$(27)+"="+CHR$(32)+CHR$(32):
700 RETURN
710 IFY5=12THEN740
720 GOSUB880
730 GOTO320
740 IFX5=31THEN770
750 GOSUB880
760 GOTO320
770 Y5=12:X5=30:GOSUB670:PRINT" POW "
780 FORN=0TO100:PRINTCHR$(7)::NEXT
790 FORN=0TO100:NEXT
800 GOSUB670:PRINT" "
810 FORN=0TO100:NEXT
820 Y5=22:X5=0:GOSUB670
830 PRINT"MA Y THE FORCE BE WITH YOU !!!!"
840 Y5=1:X5=50:GOSUB670
850 PRINT"ENEMY DESTROYED=":D1
860 D1=D1+1:IFD1=6THEN920
870 GOTO300
880 P=Y5:Q=X5:Y5=2:X5=50:GOSUB670
890 PRINT"NUMBER MISSED=":D2:D2=D2+1
900 Y5=P:X5=Q:GOSUB670
910 RETURN
920 Y5=22:X5=10:GOSUB670
930 D2=D2-1
940 Y5=20:X5=0:GOSUB670
950 PRINT"THE HOME BASE HAS BEEN SAVED-CONGRATULATIONS!!"
960 PRINT"YOUR MISSION RECORD: ";5/(5+D2)*100:">% PERFORMANCE"
970 IF5/(5+D2)*100>75THENV8=V8-50
980 IF5/(5+D2)*100<51THENV8=V8+50
990 PRINT"DO YOU WANT ANOTHER MISSION
1000 IF(INP(16)AND1)=0THEN1000
1010 X=(INP(17)AND127)
1020 IFX<>89THENSTOP
1030 GOTO270
1040 Y5=0:X5=0:GOSUB670
1050 PRINTCHR$(27)+"="+CHR$(32+P)+CHR$(32+Q):
1060 PRINT"
1070 RETURN
1080 T=T+1
1090 IFT>V8THEN1110
1100 RETURN
1110 IFX5>36THEN1116
1111 IFY5<12THEN1116
1112 X5=X5-1:Y5=Y5+1:GOSUB1050:GOSUB670:GOSUB640:GOSUB690:GOTO1120
1114 GOTO1120
1116 X5=X5+1:Y5=Y5-1:GOSUB1050:GOSUB670:GOSUB640:GOSUB690:GOTO1120
1120 IFY5>18THENPRINTCHR$(26):PRINT"YOU'RE SHOT DOWN!!":GOTO490
1122 IFY5<5THENPRINTCHR$(26):PRINT"YOU'RE SHOT DOWN!!":GOTO490
1130 T=0:RETURN
1140 IFV8<=75 THENQS="RATING=ACE PILOT"GOTO1170
1150 IFV8>=300THENQS="RATING=NOVICE PILOT":GOTO1170
1160 QS="RATING=EXPERIENCED PILOT"
1170 Y5=2:X5=25:GOSUB670
1180 PRINTQS
1190 RETURN

```

grade in classification and a resulting slower evasive action taken by the enemy. Performance record is based on the number of enemy craft destroyed to the number of misses.

- During the mission the enemy craft gradually destroys the pilot's capability to aim rockets, and thus time becomes an important factor.

Program Description

At the start of the program the instructions are listed and you are asked to classify yourself in accordance with your capabilities. At this point it is best to start off with the novice classification by typing an N. If you show promise you will be upgraded as each mission is accomplished, and can advance to ace with some practice and concentration. It should be mentioned however, that no matter how good you think you are, the computer can and will speed up enemy evasive action and it will become more and more difficult to complete the mission with good results. If the enemy craft is allowed to maneuver too far off the display you will be shot down and the game will be over.

One of the features of the game is pilot data entry without use of the return key. This was programmed by using the INP function of Altair BASIC. It is possible to maneuver the plane by just hitting one key, such as the U key, for upward motion. In order to get reliable performance of the computer with the INP function it is necessary to disable the control C function of Altair BASIC. The control C is normally used for aborting program execution and returning to command mode. The control C function is temporarily disabled in Altair 16 K BASIC Revision 4.0 by poking decimal addresses 3758 and 4031 to an unused port (port 18 on my system). The program is set up for the MITS, 2SIO board with the video monitor located at port number 16. If you have your monitor at another port, it is necessary to change lines 260, 360, 370, 490, 1000 and 1010. For example, if you have a video monitor at port 0 then change:

Line 360 to IF(INP(0)AND1)=0 THEN350
Line 370 to D=(INP(1)AND127).

These changes assume that your status and data ports are 0 and 1 respectively. Also change lines 1000 and 1010 in the same way. For those of you who wish to run the program with Altair, 8 K BASIC, Revision 3.2 you may change the control C disable routine as follows:

Line 260 POKE1422,18:POKE1514,18
Line 490 POKE1422,16:POKE1514,16

where 18 is an unused port and 16 is the video status port. Line 490 restores the Altair BASIC control C feature, and line number 260 aborts the control C, permitting pilot control direct from the keyboard without use of the carriage return key. If you enjoy programming, try this on your *Star Trek* program to eliminate the need to use the return key.

Running the Game

After typing RUN, the instructions are clearly listed and time is allowed for the average reader to absorb the mechanics of the game. You are then asked what level of competence you have as a pilot. After you type in the appropriate response and hit a carriage return, the board is displayed and the enemy craft is randomly positioned in range of the gun sight. You are allowed a reasonable time to maneuver your craft (not the enemy) to where the enemy plane is in a more central position within the gun sight, but if you delay too long or fumble, the enemy will take evasive action and it will be necessary to reposition your gun sight.

Once the plane is positioned in the exact center of the gun sight you must fire the rocket by hitting the F key. If this can be done before the plane moves out of line you will have done the job and the appropriate score will be entered in the upper righthand corner of the screen. If you fire before the plane is centrally located, a miss is recorded.

Your score and rating are adjusted appropriately after each mission (five craft must be shot down). By achieving a 75 percent or better record you can increase your rating by 50 points and eventually advance to the next higher rating. The next rating also changes the degree of evasive action taken by the enemy and hence grows with the pilot's competence. In like manner, if you fail to complete your mission, your rating will be lowered and the game will become easier, in keeping with your ability as a pilot. You will be demoted only if the number of misses exceeds the number of craft shot down.

Using Other Video Monitors

For those readers who have other types of (cursor controlled) video monitors it will be necessary to change lines 670 and 690. Line 690 homes the cursor to the upper left corner of the display and whatever

procedure is appropriate to do this on your monitor may be substituted for this subroutine. Line 670 positions the cursor at the X,Y location desired for the particular printout desired. The Y position is the variable Y5 and the X position is X5.

For example, if you want to position the printout at the exact center of the screen (24 lines by 80 characters) then Y5 is set to 12 and X5 is set to 40. Cursor control programming involves only the additional information of where to print just before the PRINT statement is issued. By using a subroutine to locate the cursor for each print statement, you avoid having to rewrite the location for every printout. In this particular program we call a subroutine at line 670 after specifying Y5 and X5. In some cases the cursor should remember where it was on a previous printout, and in that case I set the variables P and Q to the original Y and X locations for storage (see line 650).

If you haven't tried a terminal having cursor control you are missing a lot. Try this game and you may be tempted to convert some of your old business or game programs using the above techniques. ■

Word Processor + Business System

MicroDaSys Makes It Easy.

\$2899



FEATURES

- S-100 Bus
- Full-Sized Disk Drive (Standard)
- Up To Four Disk Drives
- Z-80®* Micro-Processor
- CP/M®** Disk Operating System
- Printer Interface
- Full Word Processing Capability
- Designed for Business Use

AVAILABLE SOFTWARE

- Accounts Receivable/Payable
- Payroll
- General Ledger
- Inventory
- Mailing List
- Text Processor
- Plus 500 More!

AVAILABLE LANGUAGES

- BASIC Compiler (Included)
- FORTRAN
- Pascal
- COBOL
- And Many More!

CALL OR WRITE NOW!

MicroDaSys

POST OFFICE BOX 36051
LOS ANGELES, CA 90036

(213) 935-4555

Easy to Use Hashing Function

Don Kinzer
3885 NW Columbia Ave
Portland OR 97229

Hashing, or scatter storage, is a well known and widely used technique for handling lists. Perhaps the most common usage is in assemblers and compilers where it greatly speeds the handling of symbols. This article briefly discusses the merits and drawbacks of hashing relative to other sorting and searching techniques and presents an easy to use hashing function implemented on a 6800 microprocessor.

The concept of hash tables first appeared in the literature around 1953 but it is generally accepted that hashing was used prior to that. Other names given to the same process are scatter storage, randomized storage and key transformation table. These names will be seen to be equally applicable shortly.

Using the hashing technique, a symbol (collection of alphanumeric characters) to be put in the table is processed through a hashing function to obtain an index into a storage table. This index is then used for the address of a potential storage space for that symbol. We say potential because it is possible that some other symbol could have previously hashed to the same location. Such an occurrence is called a collision and the current symbol must be reprocessed to generate a new table address which is again checked for being empty and so on until an opening is found.

When it is necessary to look up the value of a symbol a process similar to that above is performed. The symbol is processed through the same hashing function as before. Next the address is checked to make sure that it is not empty. If it is empty, the symbol is undefined. Now that we know a symbol is stored there, we must then check to see that it matches the symbol we are looking for because this may be a collision. If the symbols do not match, we have to rehash just as before until we find the symbol or an empty location.

It is possible, with a given set of symbols, a given hashing function and a specified table length, that trying to insert a particular

symbol into the table will result in an infinite number of collisions indicating no empty spaces even though the table is not full. By the same token another symbol may take many attempts before being finally inserted.

It should be quite obvious that the ideal case would be an infinitely long table space. However, a real world compromise dictates that we "waste" a percentage of the table to keep the number of rehashes low. The trade-off is very evident. The lower the percentage of table utilization, the lower will be the number of collisions. As the percentage of table utilization increases, so will the number of collisions. Furthermore, the number of collisions, and therefore the number of rehashes, directly affects execution time. It's the old memory size versus speed trade-off once again. In practice, a reasonable compromise is to shoot for 50 to 80 percent table utilization and to determine the hash count (number of rehashes allowed) empirically. If the hash count is exceeded on a symbol insertion operation, the table is declared full, but on a symbol retrieval operation the symbol is declared undefined.

When the table size and hashing function are selected appropriately, the average number of hashes is generally less than $\log_2 n$ where n is the number of symbols in the table. Compare this to a linear search which averages $n/2$ comparisons. An average assembly language program will contain about 100 labels and symbols. Hashing would average about seven collisions while a linear list would require about 50 comparisons on the average.

The crux of the hashing matter is finding a good hashing function which will minimize collisions. The procedure for this usually involves some complex mathematical analysis based on the characters expected in the symbols and their relative frequency of occurrence. The optimum hash function generally ends up being division by certain prime numbers or some other equally awkward scheme (for a microprocessor).

As an alternative to this, I offer an empirically determined hashing function that works well within the confines of an assembler. The reason for using it, however, was logically derived and goes something

5 reasons why you should not buy the electric pencil II™

© 1978 Michael Shrayer

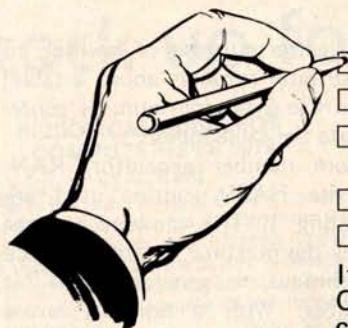

Check the appropriate box(es):

- You love typing the same copy 20 thousand times a day.
- Your secretary can type 250 words per minute.
- You're dying to spend \$15,000 on a word processing system, just for the tax investment credit.
- All your capital assets are tied up in a 10-year supply of correction fluid.
- You never commit a single thought to paper.

If you have checked one or more boxes, you do not need The Electric Pencil. On the other hand, you may want to join the thousands of people who haven't checked a single box.

The Electric Pencil II is a *Character Oriented Word Processing System*. This means that text is entered as a string of continuous characters and is manipulated as such. This allows the user enormous freedom and ease in the movement and handling of text. Since line endings are never delineated, any number of characters, words, lines or paragraphs may be inserted or deleted anywhere in the text. The entirety of the text shifts and opens up or closes as needed in full view of the user. The typing of carriage returns or word hyphenations is not required since lines of text are formatted automatically.

As text is typed and the end of a line is reached, a partially completed word is shifted to the beginning of the following line. Whenever text is inserted or deleted, existing text is pushed down or pulled up in a wrap around fashion. Everything appears on the video display as it occurs, which eliminates guesswork. Text may be reviewed at will by variable speed scrolling both in the forward and reverse directions. By using the search or search and replace functions, any string of characters may be located and/or replaced with any other string of characters as desired.

Numerous combinations of line length, page length, line spacing and page spacing permit automatic formatting of any form. Character spacing, bold face, multicolumn and bidirectional printing are included in the Diablo versions. Multiple columns with right and left justified margins may be printed in a single pass.

Wide screen video

Versions are available for Imsai VIO video users with the huge 80x24 character screen. These versions put almost twice as many characters on the screen!!!

CP/M versions

Digital Research's CP/M, as well as its derivatives, including IMDOS and CDOS, and Helios PTDOS versions are also available. There are several NEC Spinwriter print packages. A utility program that converts The Electric Pencil to CP/M to Pencil files, called **CONVERT**, is only \$35.

Features

- CP/M, IMDOS and HELIOS compatible
- Supports four disk drives
- Dynamic print formatting
- DIABLO and NEC printer packages
- Multi-column formatting in one pass
- Print value chaining
- Page-at-a-time scrolling
- Bidirectional multispeed scrolling controls
- Subsystem with print value scoreboard
- Automatic word and record number tally
- Cassette backup for additional storage
- Full margin control
- End-of-page control
- Non-printing text commenting
- Line and paragraph indentation
- Centering
- Underlining
- Bold face

Upgrading policy

Any version of The Electric Pencil

	<p>MICHAEL SHRAYER SOFTWARE, INC. 1253 Vista Superba Drive Glendale, CA. 91205 (213) 956-1593</p>
---	--

may be upgraded at any time by simply returning the *original* disk or cassette and the price difference between versions, plus \$15 to Michael Shrayer Software. Only the originally purchased cassette or diskette will be accepted for upgrading under this policy.

Have we got a version for you?

The Electric Pencil II operates with any 8080/Z80 based microcomputer that supports a CP/M disk system and uses an Imsai VIO, Processor Tech. VDM-1, Polymorphic VTI, Solid State Music VB-1B or Vector Graphic video interface. REX versions also available. Specify when using CP/M that has been modified for Micropolis or North Star disk systems as follows: for North star add suffix A to version number; for Micropolis add suffix B, e.g., SS-IIA, DV-IIB.

Vers.	Video	Printer	Price
SS-II	SOL	TTY or similar	\$225.
SP-II	VTI	TTY or similar	225.
SV-II	VDM	TTY or similar	225.
SR-II	REX	TTY or similar	250.
SI-II	VIO	TTY or similar	250.
DS-II	SOL	Diablo 1610/20	275.
DP-II	VTI	Diablo 1610/20	275.
DV-II	VDM	Diablo 1610/20	275.
DR-II	REX	Diablo 1610/20	300.
DI-II	VIO	Diablo 1610/20	300.
NS-II	SOL	NEC Spinwriter	275.
NP-II	VTI	NEC Spinwriter	275.
NV-II	VDM	NEC Spinwriter	275.
NR-II	REX	NEC Spinwriter	300.
NI-II	VIO	NEC Spinwriter	300.
SSH	SOL	Helios/TTY	250.
DSH	SOL	Helios/Diablo	300.

Attention: TRS-80 Users!

The Electric Pencil has been designed to work with both Level I (16K system) and Level II models of the TRS-80, and with virtually any printer you choose. Two versions, one for use with cassette, and one for use with disk, are available on cassette.

The TRS-80 disk version is easily transferred to disk and is fully interactive with the READ, WRITE, DIR, and KILL routines of TRSDOS 2.1.

Version	Storage	Price
TRC	Cassette	\$100.
TRD	Disk	\$150.

Demand a demo from your dealer!

IT'S HERE...

anti-magnetic protection for cassette-stored data



TAPE * SAFE METAL CASSETTE SHIELDS

Don't risk the erasure of valuable cassette-stored data through accidental magnetic-field exposure. Such irretrievable loss can occur during storage or transit if unprotected tapes are exposed to the magnetic fields produced by motors, transformers, generators, electronic equipment—even the intense transient fields induced by electrical storms. TAPE*SAFE Cassette Shields are constructed of the same special magnetic alloy used to shield cathode ray tubes and other magnetic-sensitive components. Helic-welded seams and hydrogen annealing assure optimum shielding properties. Each attractively-finished TAPE*SAFE Shield accommodates one cassette in its original plastic box. The handsome FILE DECK, in contrasting color, stores six TAPE*SAFE Shields (One FILE DECK sent FREE with each six Cassette Shields). Order direct from this ad. Visa and MasterCard telephone orders accepted.

TAPE*SAFE Cassette Shields—\$14.95 ea., postpd.
Six or more at one time—\$12.95 ea., postpd.
Inquire about quantity discounts

Data-Safe Products, Inc.
1926 Margaret St., Phila., PA 19124 • 215/535-3004
Dealer Inquiries Invited



FILE DECK

Stores six TAPE*SAFEs for quick, easy access

\$10.95
ea., ppd.

FREE with six TAPE*SAFEs

SPECIAL INTRODUCTORY OFFER

Ship _____ TAPE*SAFE Shields at \$ _____ ea.

Ship _____ FILE DECK Racks at \$ _____ ea.

Total Enclosed \$ _____ (check or money order)
Pa. Residents add 6% Sales Tax.

Name _____

Address _____

City _____ State _____ Zip _____

the calling routine needs to check if the symbol matches that at the table address. If they do not match and the location is not empty, REHASH until the hash count limit is exceeded or an empty location is found whereupon the symbol is declared to be undefined. Note that it will take exactly the same number of attempts to find a symbol as it did to put it in the table to begin with.

This has by no means been a thorough treatment of the subject of hashing but only an attempt to pass on something which works rather well in my experience. The interested reader is encouraged to do further research into the topics mentioned here. ■

REFERENCES

1. Grappel R, "Randomize Your Programming," *BYTE*, volume 1, number 13, September 1976.
2. Hopgood, F R A, *Compiling Techniques*, American Elsevier, 1970.
3. Knuth, Donald E, *The Art of Computer Programming, volume 3, Sorting and Searching*, Addison Wesley, 1973.
4. Lancaster, D, "Understanding Pseudo-Random Circuits," *Radio Electronics*, April 1975.

Processor Technology Software

New cassettes and manuals for Sol and CUTER systems.

Extended Casette Basic	5.00
Gamepac 1	5.00
Gamepac 2	5.00
FOCAL	5.00
TREK 80	5.00
EDIT	5.00
DEBUG	5.00
Cassette Assembler	5.00
PILOT	5.00

ANY 10 FOR \$40.00

ALS-8 in ROM (9216) 34.00

The above is available in limited quantity only and subject to prior sale. California residents add 6½% sales tax. Add \$3.00 for handling orders less than \$99.00.



CHEOPS ELECTRONICS

441 Swallow Ct., Livermore, CA 94550
(415) 449-8080

MICROCOMPUTER BOOKSHELF

AN INTRODUCTION TO MICROCOMPUTERS

Volume 0 — The Beginner's Book
by Adam Osborne



This book introduces computer logic and terminology to the complete beginner in the field of microcomputers. Numerous illustrations and photographs combine with clear, easy-to-follow text to provide an elementary but broad-based background.

#26-8 \$7.95

Volume 1 — Basic Concepts
by Adam Osborne

A must for anyone in the computer field, this best-selling text explains hardware and programming concepts common to all microprocessors.

#02-0 \$9.50

Volume 2 — Some Real Microprocessors
by Adam Osborne et al.

This unique reference provides objective descriptions of virtually every microprocessor on the market today. Lets you know what's available, how they work (or don't work), and how to use them. Loose-leaf. Binders and yearly updates (six issues) sold separately.

Vol. 2 book, 1978 ed. #15-2 \$25.00
Vol. 2 binder #16-0 \$ 5.00
Vol. 2 1978/79 updates #97 \$25.00
Vol. 2 1979/80 updates #94 \$25.00

Volume 3 — Some Real Support Devices
by Jerry Kane et al.

Same objective, in-depth coverage as Volume 2, but applied to support devices: memory, data converters, data communication devices, direct memory access controllers, busses, and much more. Loose-leaf. Binders and yearly updates (six issues) sold separately.

Vol. 3 book, 1978 ed. #18-7 \$15.00
Vol. 3 binder #19-5 \$ 5.00
Vol. 3 1978/79 updates #98 \$25.00
Vol. 3 1979/80 updates #95 \$25.00

RUNNING WILD - THE NEXT INDUSTRIAL REVOLUTION

by Adam Osborne

A 24-hour work week? Bionic man? Job redistribution? No one should miss this enlightening survey of the microelectronics industry and forecast for the future. Photos and illustrations. Intended for all audiences.

#28-4 \$3.95

OSBORNE SOFTWARE

Some Common BASIC Programs
by Lon Poole et al.

76 short practical programs, most of which can be used on any microcomputer with any version of BASIC. Complete with listings, remarks, descriptions and examples. Special PET cassette and TRS-80 cassette versions.



SCBP book #06-3 \$9.50
SCBP PET cassette #25-X \$15.00
SCBP TRS-80 cassette #32-2 \$15.00

CBASIC

Payroll with Cost Accounting - CBASIC #22-5 \$15.00
Accounts Payable/Receivable - CBASIC #23-3 \$15.00
General Ledger - CBASIC #24-1 \$15.00

OSBORNE/McGraw-Hill

ASSEMBLY LANGUAGE PROGRAMMING

8080A/8085 • 6800 • Z80

COMING 6809

NEW
6502

These books explain assembly language programming, the functions of assemblers and assembly instructions, and basic software development concepts. Numerous practical programming examples are included for each. All books by Lance Leventhal.



6502 ALP #27-6 \$9.50
Z80 ALP #21-7 \$9.50
6800 ALP #12-8 \$9.50
8080A/8085 ALP #10-1 \$9.50
6809 ALP (check box below to be notified of availability)

Also:

Z80 Programming for Logic Design #11-X \$9.50
6800 Programming for Logic Design #05-5 \$9.50
8080 Programming for Logic Design #04-7 \$9.50



Book/Cassette #	Price	Quantity	Amount
#			
#			
#			
#			
Subtotal			
Shipping			
TOTAL			

Calif. residents add 6% sales tax.

S.F. BART residents add 6-1/2 % sales tax.

No tax on update subscriptions.

SHIPPING (Shipping for large orders to be arranged)

All foreign orders \$4.00 per item for airmail

No charge in the U.S. on update subscriptions.

\$0.45 per item 4th class in the U.S. (allow 3-4 weeks)

\$0.75 per item UPS in the U.S. (allow 10 days)

\$1.50 per item special rush shipment by air in the U.S.

For faster shipment or credit card, phone (415) 548-2805

NAME: _____

ADDRESS: _____

CITY: _____ STATE: _____

ZIP: _____ PHONE: _____



OSBORNE/McGraw-Hill, Inc.

630 Bancroft Way, Dept. 125

Berkeley, CA 94710

(415) 548-2805

TWX 910-366-7277

S1025

Budget Building on a Bare Board

Dan S Parker
1007 3rd St #3
Davis CA 95616

For the experimenter with an eye toward saving a little money or who has a well-stocked parts cabinet, the thought of buying a blank computer board can be very appealing. It is now possible to assemble an entire S-100 computer system using your own parts and commercially designed printed circuit boards which are offered with complete documentation but with no parts. Table 1 indicates how this could be done. Even if you would rather assemble an SS-50 (6800 processor) system, read on anyway since much of what is said will apply to bare boards for those systems too (even though the selection of bare 6800 based computer boards is somewhat limited at present). Savings sometimes reach as much as 30 to 50 percent over the purchase price of a kit or an assembled board if parts are purchased carefully and only as needed. Three companies, Cybercom, Solid State Music (now SSM) and Ithaca Audio, offer low cost bare printed circuit boards for S-100 experimenters who are willing to do a little shopping for parts bargains and still have a professionally designed system.

I would like to summarize a few of my experiences assembling bare computer boards. It can be a rewarding endeavor if a few minor pitfalls are avoided.

Documentation and Software

Have you ever tried to assemble a circuit board with no parts layout, schematic, silk screen mask, or other documentation? Of course it would be impossible. All blank boards come with some form of documentation as just mentioned. Normally it consists of the preceding, plus a sheet or two of instructions on how to assemble the board. Don't expect elaborate and expensive manuals with your board. My experience has been that the documentation included with most bare boards is adequate for those who have already assembled one or more kits and who have the basic skills.

Many companies also offer the documentation packages for their boards as separate packages, usually priced at a dollar or so to cover printing and mailing costs. If you're really interested in a board, this is a very good investment. Always ask if the docu-

mentation can be had separately—this isn't always advertised.

Some types of computer cards demand that software support be provided. Foremost among these are video display and modem boards, which usually require a driver program to communicate with the interface. All such bare boards that I've seen offered include such software, although usually only in a hard copy source form which must be relocated or loaded in by hand.

About the Table

Table 1 lists some of the bare S-100 compatible boards on the market today. A few words are in order concerning the bare board tabulation. Many companies act as distributors for boards produced by other manufacturers. The table attempts to list only the main or representative distributor of the product. Prices can change rapidly, and different dealers may offer the same board for varying prices. A very handy address reference to these companies and a listing of hobby computer products which contains many of the boards listed in table 1 can be had by sending a business size, self-addressed, stamped envelope to S-100 Reference List, c/o Robert Elliott Purser, POB 466, El Dorado CA 95623.

Dealer Liability and Warranty

Almost without exception, you take a risk in purchasing a blank board if something goes wrong. The same is true of buying a complete kit. The adage "you get what you pay for" is certainly true in the bare board business. Dealer liability is limited to the replacement of the board if it proves defective. Any parts, such as sockets, that can't be salvaged if the board proves defective in design or manufacture are the burden the buyer must accept. Be sure you understand the limits of the warranty that the dealer offers. Also keep in mind that the dealer has no control over the quality of parts with which you choose to populate your board nor the care you take in its assembly. As a result, he or she is much less likely to provide extensive support or advice. I much prefer purchasing bare boards from companies that also offer kits and assembled versions of the same board.

Buying Parts

Purchasing parts for a blank board can be a real education. Assuming a parts list is in hand, it is a small chore to look through the prices in the advertisements, choosing which parts to order from which company. Limit yourself to purchases from no more than two or three companies if you can. If you've

About the Author

Dan S Parker works with microcomputers as a hobbyist (with an Altair 8800a), and in his research works as a doctoral student in the Physics Department of the University of California at Davis. He has developed a disk based 8080 data acquisition system for on and off line data retrieval and plotting of cryogenic experiments on magnetic phenomena of rare earth crystals.

had trouble or have heard of others having trouble locating a part, call the company that lists that part in their catalog and ask for a stock check. It's nice to do business with a company that has a toll free telephone number.

Often you can save money on parts and increase your spare parts supply at the same time. Pull-up resistors and bypass capacitors

are two items that are needed in quantity. For example, I recently finished a board that needed 40 4.7 K ohm resistors, which were priced at 5¢ each for a total of \$2. But the same company offered a package of 100 resistors of any one value for 1.7 cents each, totalling \$1.70. It doesn't take much to figure out the better deal. The disk ceramic capacitor often used for noise bypass on

Table 1: A summary of available blank boards and where to obtain them.

	Description	Bare	Partial	Company	Comments
Programmable Memory Boards	32 K static #300 (8 K)	\$38.00		F Reichert Sales	
	8 K	22.50		Electronic Systems	
	8 K	29.95		Digital Research (Texas)	
	8 K	25.00		Jade	
	MB-4 (4 K)	29.95		Cybercom	
	MB-6A (8 K)	29.95		Cybercom	
	MB-7 (16 K)	29.95		Cybercom	
	MEMI (8 K)	25.95		Wameco	
	8 K	25.00		Ithaca Audio	
	16 KDR	35.00		Ithaca Audio	16 K and 64 K dynamic
	8 K	29.95		Barnes Electronics	
	16 K	35.00	88.00	Digital Micro Systems	
LOGOS-1 (8 K)	21.95		Advanced Computer Products		
32 K	59.95	99.95	Advanced Computer Products		
8 K	29.00		Duston		
Processor Boards	8080A	34.95		Advanced Computer Products	
	8080A	30.00		Jade	
	8080A	25.95		Wameco	
	Z-80	35.00		Jade	
	Z-80	34.95		Advanced Computer Products	
	CPZ80	35.00		Ithaca Audio	
	6800	30.00		MRS	
6502	39.95		CGRS Microtech		
Input/Output	MFIO-1	49.95		MSD	Multi-I/O
	TIDMA	35.00		Electronic Systems	Cassette I/O
	80-103A	49.95		DC Hayes	Modem
	IO-2	25.00		Cybercom	Parallel I/O
	IO-4	25.00		Cybercom	Serial and Parallel
	IA-1100	25.00		Ithaca Audio	64 by 16 Video
	VB-1B	29.95		Cybercom	64 by 16 Video
SCT-100		95.00	Xitex Corp	64 by 16 Video and Parallel port	
Master I/O	47.50		Space Time Products	Serial, Parallel, Programmable and Read Only Memory	
Tarbell	40.00		Tarbell Electronics	Disk Controller	
Read Only Memory	16 K		57.50	Digital Research (Texas)	2708s
	JG 8/16	30.00	59.95	Jade	2708/2716s
	EPM-1	30.00		Wameco	4 K 1702As
	EP 16 K	25.00		Ithaca Audio	2708/2716s
	4 K	29.95		Barnes Electronics	
	Bytesaver		136.00	Cromemco	8 K 2708s
	Byteuser	24.95	64.95	Advanced Computer Products	8 K 2708s
	MB-3		64.95	Cybercom	2 K/4 K 1702As
MB-8		84.95	Cybercom	8 K/16K 2708s memory	
MB-9		72.00	Cybercom	Also programmable	
32K	30.00		Wameco	2708/2716s	
Mother Board	13 slot	35.00		Jade	
	15 slot	40.00		Cybercom	
	11 slot	29.50		Vector Electronic	Active terminations
	20 slot		76.00	Thinkertoys	Active terminations
	18 slot	29.95		California Industrial	Active terminations
12 slot	35.00		Wameco	Active terminations	
Miscellaneous	Better Bug Trap	30.00	45.00	Micronics	
	Real Time Clock	80.00		Wameco	
	CompuTime CT100			CompuTime	
	S-4 Front Panel		20.00	Sargents Distributors	I/O and read only memory
Digital/Analog	34.00		Pinnacle Products		
Buss Terminator	21.95		VAMP		

memory boards is another item that is sometimes more cheaply purchased in bulk, especially the 0.1 and 0.01 μ F varieties. 14 and 16 pin socket prices really start to drop if you buy in slightly larger quantities, too.

One rule of thumb holds true: it only takes one back ordered or hard to find part to keep your board inoperable. A catalog listing of a part does not necessarily indicate that that company has those parts.

Why Companies Sell Blank Boards

You might think that a company marketing bare boards as well as kits and assembled units would be competing against itself, particularly since you can almost always save money over the kit price by purchasing your own parts separately. Volume and exposure seem to be the two big reasons. First, circuit boards, like everything else, are cheaper in larger production runs. Selling off the extra boards for a proven product reaches the additional market of do-it-yourself computerists who like to go to the extra trouble of purchasing parts separately for the promise of saving a few dollars. Secondly, marketing the bare board doesn't increase the support demand at nearly the rate that support must be provided to the kit or assembled board purchaser. Finally, for some types of boards,

exposure can be increased dramatically by offering the board blank. A case in point is the D C Hayes modem board listed in Table 1. Offering it bare significantly increases the number of people who have the board. Wide customer acceptance and use is what communications and computer interface standards are all about.

A Few Final Dos and Don'ts

Never undertake the project of populating a bare board without first obtaining a copy of the parts list and pricing the needed parts. Write or call the company and ask for a parts list in advance of purchasing the board. A self-addressed, stamped envelope when requesting the list is a nice gesture.

Don't get caught on a special "secret" deal of blank boards being dumped on the market because one of the chips it used is no longer available, or has become prohibitively expensive, or the board needs extensive foil cutting and jumpers to work. Buy bare boards as you would a kit or completed board: only from a reputable company.

Many companies offer "partial kits" which consist of the bare board and especially hard to find components, or, in the case of memory boards, 16 K byte and 32 K byte boards with only a partial complement of memory on them. Table 1 includes a column of some boards that are presently offered as partial kits. Plan ahead so that the parts will be there when you need them, and substitute parts sparingly. Don't buy more blank boards than you need right away, hoping to store the extras away for a rainy day. The market is changing too quickly. Most of the boards listed in table 1 have appeared within the last year. As an example, I purchased extra 4 K byte and 8 K blank memory boards over a year ago with the idea of slowly populating them with 2102 memory chips. The boards still sit gathering dust, obsoleted by the newer 16 K byte boards, and higher density, lower power, lower cost per bit memory chips. It's not cost effective to populate my old boards anymore.

Buying and populating blank boards can be a significant money saver. I figure that, having populated about a dozen bare boards in the past two years, my savings have equalled at least the price of a fully populated 16 K byte memory board, if not more. In almost all cases, I would never have been able to afford the cash outlay for such a board if it were only offered as a kit or fully assembled. Spend a little time considering the above, and you'll be generously rewarded in savings on your board purchase. For more information about the companies in table 1, contact me or your local computer store. ■

Interactive Computer Graphics Software.

For Microsoft and DEC* Fortran

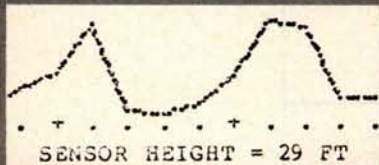
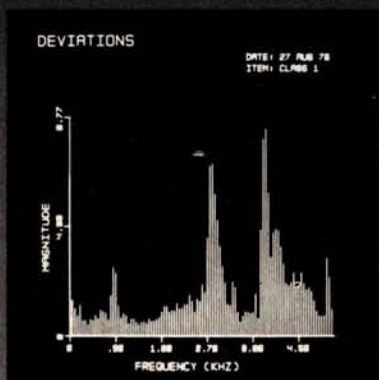

The above graphs are examples of the GSP. The top graph was made on a X-Y-Z self-refreshed display. The bottom graph was made on a Diablo® 1620 printer.

COMPCO's Interactive Computer Graphic Subroutine Package (GSP) is now available for small computer systems. The subroutine package will drive many different devices ranging from standard CRT terminals to incremental plotters, and even high speed self-refreshed raster scan displays. The complete package is written in standard Fortran IV, making it portable to all computers, including mini and micro systems.

The entire set of over 20 subprograms, including drivers for a CRT terminal and a Diablo 1620 printer, sells for \$400. Drivers for other devices may be added.

*Trademark of Digital Equipment Corp.

Compco

8705 North Port Washington Road
Milwaukee, Wis. 53217 414/351-3404
COMPUTER SPECIALISTS

BYTE's Bugs

Pseudorandom Errors

A typographical error occurred in 2 program listings in the article "Three Types of Pseudorandom Sequences" by C Brain Honess in the June 1979 BYTE, page 234. In listing 1 on page 236, line 150 should have been:

150 LET A = N/10000.

In listing 2 on page 238, line 200 should have read as follows:

200 PRINT
"DEGENERATION AFTER";
I; "NUMBERS."

A note on a BOMB card mailed from Greenville SC brought these errors to our attention.

Marsport Bugs Defeated

Dr Reimut Wette has informed us of several typographical errors which occurred in "Marsport, Here I Come" (April 1979 BYTE, page 84). The corrected segments of code for listing 1 are shown here circled.

024	*LBLA
025	STOI
026	*LBLE
027	GSBd
028	CF0
114	*LBLE
115	-P
116	RI
117	X=Y
118	RI
119	-P
120	RTN
121	*LBLE
122	7
123	X=I
124	STO0

201	9
202	x
203	STO7
204	GSBC
205	+
206	STO1
207	STO2
208	STO3

Gravitational Problems

Mr Hinrichs seems to have developed a much better than average planetary landing program ("Marsport, Here I Come," April 1979 BYTE). He is especially to be congratulated on his adaptation of the physics of celestial mechanics to a program on a programmable calculator! However, on page 100 he has made a common physics error in saying, "The attraction of gravity is exactly balanced by the centrifugal force at all times." The attraction of

gravity is not balanced by anything. In fact, if it were balanced at all times, it would not have any effect and there would be no orbit — only straight line motion at constant speed. What Mr Hinrichs in his equations on page 104 implies is that the attraction of gravity interferes with the tendency of a body to maintain a constant speed and direction just enough to continuously change the direction (circular orbit) without changing the speed. This is true only for a circular orbit. In other cases, the unbalanced force of gravity can change speed as well as direction.

Fortunately this confusion between inertia and a force (called centrifugal) has no effect on the workings of what is an excellent program.

Robert Reiland
RD #1
Portersville PA 16051 ■

TRS-80 LEVEL II

\$750. COMPLETE SYSTEM

Now the world's most popular micro-computer, with 16K of memory and Level II basic for only \$750, complete. We accept check, money order or phone orders with Visa or Master Charge. (Shipping costs added to charge orders).

Disk drives, printers, peripherals, software and games...you name it, we've got it (Both Radio Shack and other brands). Write or call for our complete price list.



Shown is Level I. Level II includes alphanumeric keypad.

Full 90 day Radio Shack Warranty.

C&S ELECTRONICS MART Ltd

AUTHORIZED DEALERSHIP

Radio Shack®

32 E. Main Street • Milan, Michigan 48160 • (313) 439-1400

Clubs and Newsletters

DIRECTORY

The following is the third BYTE Clubs and Newsletters Directory. The directory was compiled from information supplied by the various clubs listed. A form was sent to all clubs and newsletters listed in the second directory requesting up-to-date information. If the form was not returned, we deleted the club from the third directory. In addition, the listing was correlated with back issues of the magazine and materials on file in the BYTE offices. If information is missing in one or more categories, it means the data was not provided. We will be keeping the file available and updating it for the next directory; so, if there are errors or if you have a new club which has just been formed, send the information to: Laura Hanson, Clubs and Newsletters Editor, BYTE Publications Inc, 70 Main St, Peterborough NH 03458.

The listings follow this form:

1. Name of organization
2. Mailing address
3. Meeting location
4. Meeting algorithm
5. Newsletter or publication
6. Contact person
7. Contact phone number
8. Dues or subscription fees
9. Special interests
10. Other comments

Clubs

Zips - 00000 - 10000

1. **MUMPS Users Group**
2. POB 208
Bedford MA 01730
3. 1978 Atlanta, 1979 San Diego, 1980 Cape Cod
4. Yearly in June
5. *MUG Quarterly*
6. R E Zapolin, Executive Director
7. (617) 271-2534
8. \$25 per year
9. US Branch - Exchange of information among users of ANSI Std MUMPS (and older dialects), offer tutorials and publications on MUMPS language.
10. ANSI MUMPS is used world-wide on maxis,

minis, microcomputers in medical, commercial and educational applications. A large number of public domain programs exist. A list of publications is available.

1. **New England Computer Society**
2. POB 198
Bedford MA 01730
3. Mitre Corp, Cafeteria, Rt 62, east of Rt 3, Bedford MA
4. First Wednesday of the month
5. *NECS Newsletter*
6. Dave Mitton, Secretary
7. (617) 493-3154 days
8. \$6 per year
9. User Groups in PET, APPLE, 6800, Digital Group, and TRS-80.
10. Computerized Bulletin Board System (CBBS), (617) 864-3819.

1. **TRUGEM (TRS-80 Users Group of Eastern Massachusetts)**
2. 61 Lake Shore Rd, Natick Ma 01760
3. Cochituate MA (call or write first)
4. Second Wednesday of each month at 7 PM
5. *The TRUGEM Newsletter* (monthly)
6. A Richard Miller, President

7. (617) 653-6136 (9 AM to 9 PM)
8. \$10 per year local or remote. Send fees to: Ed Robinson, TRUGEM Treasurer, 11 Leighton Rd, Auburndale MA 02166.
9. TRS-80 hardware and software; peripherals from Radio Shack and independents; Programs Exchange Library (non-commercial); demonstrations and sales of commercial hardware and software encouraged.
10. Meeting monthly since January 1978. All TRS-80 users are invited to attend.

1. **The Boston Computer Society**
2. 17 Chestnut St, Boston MA 02108
3. Commonwealth School, 151 Commonwealth Ave, Boston
4. Fourth Wednesday of the month at 7 PM
5. *The BCS Update* (an enormous publication with nation-wide industry exclusives and news of New England)
6. Jonathan Rotenberg
7. (617) 227-9178
8. \$10 per year (includes all subgroups)
9. User Groups: PET, Sorcerer, OSI and North Star. Subgroups: education, business applications, Pascal and beginner tutorials. Others on the way.
10. A complete resource center for the microcomputer industry which, in addition to running meetings and publishing a newsletter, publishes books, runs trade shows, other seminars and provides a free consulting and problem solution service by phone.

1. **TRS-80 Club of Arlington.**
2. 96 Dothan St, Arlington MA 02174
3. Same as above
4. Write for details
5. Yes; send \$1 donation and 2 long, self-addressed, stamped envelopes for 2 issues.

6. Poi Pow
 9. TRS-80 disk business software; library includes: data base management, word processor, inventory, mailing list, stock, accounting, etc.
 10. Interested in good business software at lowest costs; we review business software written for the TRS-80. No games. We review new developments in software and hardware for the small business system.
1. **RICH (Rhode Island Computer Hobbyists)**
 2. POB 599, Bristol RI 02809
 3. Various locations around Providence
 4. Third Tuesday of the months of March, April, May, June, September, October, November
 5. Yes
 6. Emilio D Iannuccillo
 7. (401) 253-5450
 8. \$3 per year
 10. We are a small active group dedicated to keeping abreast of current technology, plus lending a hand to each other regarding hardware and software. We also give help and advice to new comers into the world of microprocessors.

1. **Connecticut Computer Club**
2. c/o Leo Taylor, 18 Ridge Ct W, West Haven CT 06516.
3. Suffield Library, Suffield CT 06708
4. First Thursday of each month
5. *Connecticut Computer Club Newsletter*
6. Leo Taylor, Secretary
7. (203) 389-6551
8. 1980 dues \$6
10. We have 2 talks per meeting; generally one on software and one on hardware. The club does not specialize on any one machine. We have 65 members at the moment with a turn-out of about 40 per meeting. The club was featured in the first issue of *onComputing* magazine in an article by one of our members.

HAYDEN PROUDLY ANNOUNCES...

SARGON

II

The Champ of Champs



"SARGON II — Buy this program, when it becomes available — ...an evaluation routine that enabled it to beat the giants! ... unequaled in the endgame..." *Personal Computing*, July, 1979.

Because new algorithms have been added, the program is able to: push passed pawns toward queening; play a stronger end game; and range into deeper play levels at end game without user direction. And, the computer displays the levels of play at which it is thinking and also shows the move it is currently thinking of making, changing the move shown until its final choice is made. **SARGON II** has 7 levels of play, and levels 0-3 play in tournament time. It has a ran-

domized opening book up to 7 levels of play for 3 moves. When setting up the board, the user can scan up and down, left and right. And finally, you

can use the hint option at any level but 0 and request **SARGON II** to tell what the best next move is. Available now — #03403, TRS-80 Level II; #03404, Apple II; \$29.95. Coming soon for CP/M, SORCERER, and PET.

Check out these other Hayden Computer Program Tapes:

- BACKGAMMON
- GAME PLAYING WITH BASIC
- MAYDAY • CROSSBOW
- BATTER UP!!: A MICRO-BASEBALL GAME
- MICROTypING
- ENGINEERING MATH-1
- GENERAL MATH-1

Available at your local computer store

Hayden — the computer program tape publisher!



1980 Hayden Computer Calendar will be available in October!

- full-color original computer art
- complete program for perpetual calendar
- computer anecdotes



Hayden Book Company, Inc.
50 Essex Street, Rochelle Park, NJ 07662

1. **Amateur Computer Group - New Jersey Inc**
2. U.C.T.I. 1776 Raritan Rd, Scotch Plains NJ 07076
3. Union County Technical Institute, Rutgers University, County College of Morris and Middlesex County College.
5. *ACG-NJ News*
6. Sol Libes or Marty Nichols
7. (201) 277-2063 or (201) 361-7180, respectively
8. \$8 per year
9. Have following User Groups: 8080/Z80; 6800; KIM; TRS-80; PET; Apple; and Pascal.
10. Run classes and have software libraries; publish annual membership directory; over 1000 members; annual "Trenton Computer Festival" held at the end of April with a 5 acre computer flea market. Chapters in Morris and Ocean counties.

1. **Data Processing Club**
2. c/o Dennis M Lloyd Business Studies Division Gloucester County College, Tanyard Rd, Sewell NJ 08080
3. Same as above
6. Dennis M Lloyd
7. (609) 468-5000 Ext 242
8. \$5
9. All data processing areas.
10. We wish to expand data processing education outside of the classroom.

Zips - 10000 - 20000

1. **Microcomputer Business Users Group**
2. 161 W 75 St, New York NY 10023
3. Baruch College, Manhattan
4. Third Thursday of the month
5. *BUG Newsletter*
6. Dr Laird Whitehill
7. (212) 580-3589 (re:BUG)
8. No dues, subscription \$10 for '79
10. A group for vendors of software and users of software who are serious about using or vending microcomputers for business purposes. Guest lecturers and panel discussions concentrate on ap-

plication and system software evaluations, as well as such topics as how to develop and sell micro-computer software products. Group publishes a newsletter which keeps those who did not attend informed about meeting content and exact place of next meeting.

1. **Long Island Computer Association**
2. 35 Irene Ln E, Plainview NY 11803
3. New York Institute of Technology
4. Second Friday of the month for the 8080 subgroup; third Friday of the month for the regular meeting and subgroups
5. *The Stack*
6. Aileen Harrison
7. (516) 938-6769
8. \$10 per year
9. Pascal, 8080, 6800, PET, TRS-80, North Star, etc.
10. We meet the third Friday of the month with guest speakers, show and tell, hands-on demonstrations etc. We have many subgroups, and have 170 members.

1. **Mohawk Valley Microcomputer Club**
2. POB 331, RFD 1, W Carter Rd, Rome NY 13440
3. Varies
4. Third Tuesday of the month
5. *Micros Along the Mohawk*
6. Mike Troutman
7. (315) 336-0986
8. \$2 per year (includes newsletter)
9. Several special interest groups: 6800, 8080/Z80, and beginners.
10. Membership of approximately 100. Very high predominance of SwTP 6800 systems (=75% versus 25% for all others).

1. **Apple Byter's Corps**
2. 225 Walton Dr, Snyder NY 14226
3. Buffalo Savings Bank, Sheridan-Harlem Branch, 3980 Sheridan Dr, Amherst NY 14226
4. Every third Friday at 7:30 PM
5. Monthly, no particular title

6. Gary Weir, President and typist
7. (716) 839-3486
8. \$10 per year
9. Exchanging programs; helping new Apple II owners. We have begun a computer network and special interest groups in assembly language programming and computer-assisted instruction programming. Newsletter enhancement is the current rage.
10. We are growing too quickly to settle on any firm objectives (as our numbers grow, so do our problems and potentials). We do want growth, but could use the help of well-established, similar groups.

1. **Rochester Area Microcomputer Society (RAMS)**
2. POB Drawer D, Rochester NY 14609
3. Rochester Institute of Technology Room 1030 Bldg 9
4. Second Thursday of each month
5. *Memory Pages*
6. Mike Ciaraldi
8. \$7.50 per year (1978-1979)
9. URTH (University of Rochester FORTH), 6800/6809/68000 special interest group, and a Pascal interest group.
10. As a club, our largest problem is getting programs that most of the membership can run.

1. **AM-100 Users Group**
2. 616 Long Pond Rd, Rochester NY 14612
4. Local meetings arranged by invitation.
5. *Newsletter for AM-100 Users Group*
6. Lefford F Lowden
7. (716) 227-0841
8. \$15 in US and Canada, \$36 International
9. System software and user developed software; bugs and their fixes; programming techniques; and feedback among members.
10. Aimed at owners, users, and potential owners of the Alpha Microsystems AM-100 computer system.

1. **Central Pennsylvania Computer Club**
2. 3263 Bull Rd, York PA 17404
3. Varies, York-Lancaster area
4. Third Friday of even months, and the fourth Wednesday of odd months
5. *Data Dump*
6. Cletus Hunt III, York area Joseph Pallas, Lancaster area
7. (717) 764-4977, (717) 569-3137 respectively
8. Currently being re-evaluated
9. Many 6800 users, but no organized special interest group.
10. Emphasis is on informal exchange of information among club members and display of members' computers.

1. **Philadelphia Area Computer Society (PACS)**
2. POB 1954, Philadelphia PA 19105
3. LaSalle College Science Building
4. Third Saturday of each month
5. *The Data Bus* (monthly)
6. Dick Moberg
7. (215) 923-3299
8. \$10 per year, \$5 for students
9. Subgroups in the following areas: Apple; TRS-80; PET; Robotics; spaceflight simulation; and others. Courses in BASIC; Pascal; home-brewing; computers for kids; Selectric repair; and others.
10. Current membership is approximately 350. Average meeting attendance is over 100 people. Meetings consist of courses and subgroups followed by the main meeting at 2 PM. A mini flea market and mapping session follow the meeting. For more information call the PACS Hotline (215) 925-5264.

ZIPS 20000-30000

1. **Washington Amateur Computer Society**
2. 4201 Massachusetts Ave, #168, Washington DC 20016

Subscribe now to **Strategy & Tactics**
— and get a

FREE GAME

SPI, the world's largest publisher of historical simulation games, wants you to subscribe to **Strategy & Tactics** — a fascinating and authoritative bi-monthly magazine of military history. Because we're confident that exposure to **Strategy & Tactics** and simulation gaming will be the beginning of a long-term customer and reader relationship with SPI, we'd like to give you a free, full-fledged simulation game to start you off (see description at right). Moreover, **Strategy & Tactics** itself has a simulation game in *every* issue (as a companion piece to its main article) so you'll get a new game as part of each issue in your subscription. **Strategy & Tactics** and SPI games are a fresh and exciting way to gain insights into the great conflicts of history. This offer is open only to brand new subscribers. Act now!

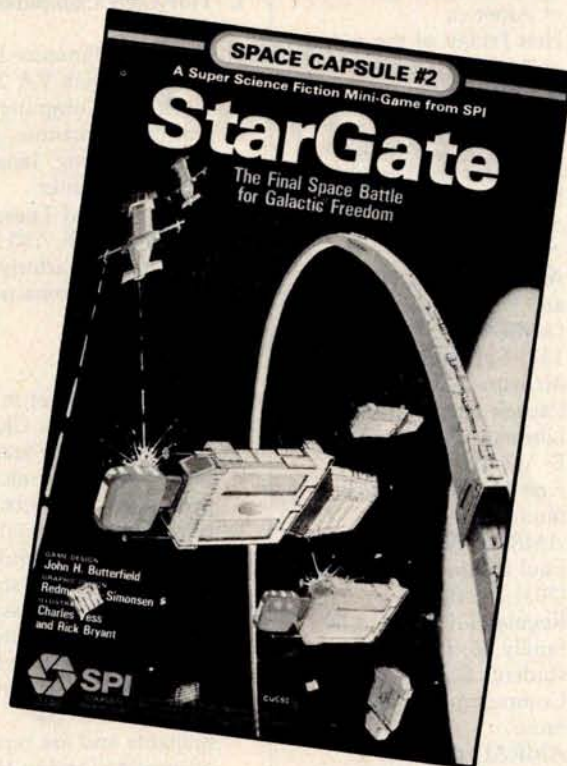

With the first issue of your new subscription to *S&T* we'll send you a free copy of *StarGate*, an action-filled game of intergalactic conflict. As the Virunian oppressors, tyrants of the Milky Way, return home in tatters from a conflict in another galaxy, they are pounced upon by the long down-trodden races who rise in rebellion. Includes fewer than 100 cardboard playing pieces (for easy playability), 11" x 17" map, and complete rules, all folding to a handy 5½ x 8½ size that slips into a re-usable plastic envelope.

**Game Normally sells for \$3.95—
it's yours FREE for subscribing to S&T!**

SPI has been serving customers by mail since 1970



Send check or money order to:

SPI Dept. 1094
257 Park Avenue South
New York, New York 10010

Send me my free game and enter my *S&T* subscription for:

1 yr. (6 issues) \$16 2 yrs. \$30 3 yrs. \$42

We recommend the purchase of one or more of the following games if you are a player new to the hobby.

Freedom in the Galaxy \$19.95 *John Carter, Warlord of Mars* \$19.95 *StarForce* \$12.00

name _____
street _____ apt # _____
city _____ state _____ zip _____

FOREIGN ORDERS: Add 20% handling charges. Payment must be by Postal Money order (in US funds) or check drawn against US bank. Customer pays all duties and tariffs.

FOR OFFICE USE ONLY!	Cus. Code	Total	Credit	Postage	Tax

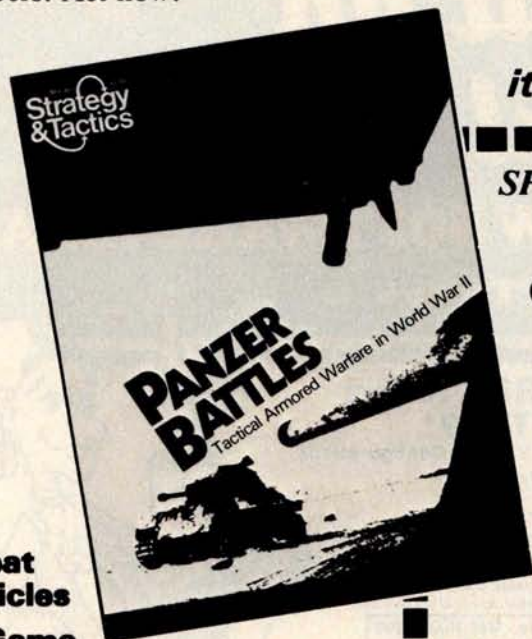

- ★ Great Articles
- ★ A Game in every issue
- ★ Winner for three years running of the hobby's award for **BEST MAGAZINE**

3. First floor hall, Keane Hall, Catholic University of America
4. First Friday of the month at 7:30 PM
5. JWAC
8. \$3.50 per year
9. Organized to provide a forum for the computer hobbyist and student of computing science.

1. **Amateur Radio Research and Development Corp (AMRAD)**
2. 1524 Springvale Ave, McLean VA 22101
3. Patrick Henry Branch Library, 101 Maple Ave E, Vienna VA 22180
4. First Monday of each month at 7:30 PM
5. *AMRAD Newsletter*
6. Paul L Rinaldo, President
7. (703) 356-8918
8. Regular \$10; second in family \$5; full-time students \$2.
9. Computers and amateur radio.
10. AMRAD operates a Computerized Bulletin Board System (CBBS) in the Washington, DC area. Phone No. (703)

281-2125.

1. **Tidewater Computer Club**
2. 677 Lord Dunmore Dr, Virginia Beach VA 23462
3. Electronic Computer Programming Institute, Janaf Office Building, Janaf Shopping Center
4. First and third Tuesday of each month 7:30 PM
5. *Hardcopy* (quarterly)
6. C Dawson Yeomans, President
7. (804) 420-6379
8. 50¢ per month
9. A general interest in microprocessors. Club members own at least one of all major microprocessors. Subjects at meetings and special projects often are useful on many microprocessors.
10. Special interest classes precede each meeting at 6:30 PM. Special projects are conducted at times convenient to participants and are reported at meetings and in the *Newsletter*.

1. **Triangle Amateur Computer Club**

2. POB 17523, Raleigh NC 27514
3. Dreyfus Auditorium, Research Triangle Park NC
4. Last Sunday of the month
9. The club is dedicated to the advancement of interest in amateur or personal computing.

1. **Carolina Apple Core**
2. 5212 Inglewood Ln, Raleigh NC 27609
3. Different locations
4. Third Tuesday of the month
5. Yes
8. \$5 per year

Zips 30000-40000

1. **Indian River Computer Society (IRCS)**
2. c/o Florida Institute of Technology (Electrical Engineering Dept) Melbourne FL 32901
3. Florida Institute of Technology Campus
4. Meetings are held twice a month
6. Lee Zaretsky

7. (305) 723-3701 (Electrical Engineering Dept Extension)
8. \$2 per 10-week quarter
9. IRCS is dedicated to hobbyist microcomputers and their many applications.
10. Although IRCS meetings are geared to fit into the quarter schedule of the university, it does not mean that members must be students. Anyone interested in microcomputers is invited to attend our meetings and join if they like what they see.

1. **Space Coast Microcomputer Club**
2. 315 Inlet Ave, Merritt Island FL 32952
3. Merritt Island Public Library Auditorium
4. Fourth Thursday of each month
5. *Enterprise* (monthly)
6. Ray O Lockwood VP, Editor
7. (305) 452-2159
8. \$5 per year
9. Primarily S-100 systems.
10. Affiliated loosely with Kennedy Space Center.

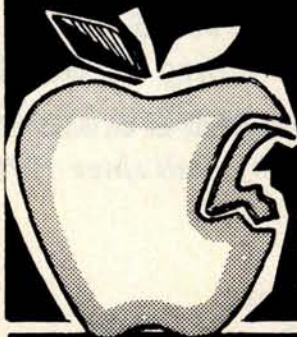

Commit an Original Sin

with a **FAST NEW SOFTWARE IDEA** For Apple II Users...

How About POSTING 1,000 RECORDS to the GENERAL LEDGER in 7 MINUTES?*

It's possible with NewWare's INTERACTIVE system that has been SERVICE BUREAU TESTED and CPA APPROVED!

Individual Packages Are:

- | | |
|------------------------|----------------------|
| 1. General Ledger | 4. Inventory |
| 2. Accounts Receivable | 5. Payroll/Personnel |
| 3. Accounts Payable | 6. Order Entry |
| | 7. Mail List |

Order Today: Each Package \$120.00*

- *Disk with Source Code, add \$10.00 (shipped only with packages)
 *Disk with Demo Data, add \$10.00 (shipped only with packages)

402/339-7352

Packages Available for Various Configurations

Standard No Charge Features:

- Terminal or printer report selection
- High Speed Journal to Ledger Posting
 - A. Automatic General Ledger Journal Transaction generation
 - B. Automatic Inventory transaction generation
 - C. Automatic Accounts Receivable transaction generation
 - D. Real time accounts receivable application system

* Prolong Your Apple - Get 10,000,000 Bytes with Corvus Hard Disk Drive - Call or Write for full details

If you're a Member of Software Central Call to see our programs in operation

NEWWARE 8525 Park Drive, Dept. B
 Omaha, Nebraska 68127



Please Note:
 All of our packages are guaranteed to operate within design specifications.

CP/M[®] Software Tools

Have you thought about text editing?

Our **ED-80 Text Editor** offers a refreshing new approach for the creation and editing of program and data files conversationally — and it saves money! Its powerful editing capabilities will satisfy the most demanding professional — yet it can still be easily used by the inexperienced beginner.

Look at these outstanding features:

- By far the best text editor available for microcomputer-based systems.
- Repays its initial cost many times over with its unique time-saving editing capabilities.
- FULL SCREEN window displays for viewing and editing data a page-at-a-time, rather than line-by-line.
- Forward and backward scrolling in the FULL SCREEN mode.
- Displays the results of every edit command.
- Commands include forward or backward Locate and Change, Insert, Delete, Replace, Inline, Input, Print, List, Window, Get, Put, Macro, Tabset, Append, Case, Scale, and Dump.
- Simple line-oriented commands with character string manipulation capabilities.
- Text may be located by string value, by line number, or by relative line number.
- Global string search and replace capabilities.
- Commands for moving, copying, and merging edit files on the same or different diskettes.
- Self-explanatory diagnostic messages.
- Single keystrokes for the most commonly used commands.
- Safeguards to prevent catastrophic user errors that result in loss of the edit file.
- Designed for today's high speed CRT's, video monitors, and teletypewriter terminals.
- Thoroughly field tested and documented with a User's Manual of over 60 pages.
- Compatible with existing CP/M edit files and derivative operating systems.

And remember — in today's interactive programming environment — the programmer's most important software development tool is the text editor. Our **ED-80 Text Editor** is working in industry, government, universities, and in personal computing to significantly cut program development time and high labor costs. Why not let **ED-80** begin solving your text editing problems today?

Mail to: SOFTWARE DEVELOPMENT & TRAINING, INC.
P. O. Box 4511, Huntsville, AL 35802

ED-80 is protected by copyright and furnished under a paid-up license for use on a single computer system.

Please send additional information.

Send Diskette, User's Manual, and paid-up license agreement \$99.00

Specify SINGLE DENSITY Diskette size 5" 8"

Send User's Manual (credited on purchase of a paid-up license) \$10.00

Check or money order enclosed for \$

Please charge to my credit card. VISA Master Charge

Card No. _____ Bank No. _____ Exp. Date _____

NAME _____

ADDRESS _____

CITY _____ STATE _____ ZIP _____

SIGNATURE _____ C-1

SOFTWARE DEVELOPMENT & TRAINING, INC.
Post Office Box 4511 — Huntsville, Alabama 35802
Dealer Inquiries Welcomed

© CP/M is a trademark of Digital Research

When you "talk" ... we "listen."



With our new IEEE-488 Interface

Our popular series 40 printers are now available with an IEEE-488 compatible interface or an industry standard Buffered Parallel interface. Both interfaces include a line buffer and software addressability. Featuring our famous commercial quality construction, the new models start at \$585 in singles. Other models available are the low cost Parallel ASCII starting at \$425 and an RS232/Current Loop interface beginning at \$575. Generous OEM discounts are available. All models are complete stand-alone units with a 40 column impact dot matrix printer and a 64 character ASCII set. Includes power supply, casework and interface electronics.



For more information write to:
MPI 2099 West 2200 South,
Salt Lake City, Utah 84119
or call (801) 973-6053

Eliminates the Expansion Chassis SAVE!

H&K Serial Interface Bidirectional Parallel to Serial Converter

RADIO SHACK CR1

Any RS232 Serial Printer

RS232C — \$150.
20 MIL — \$185. (optional)

TERMS:
C.O.D. and Cashier's Check
Shipping and Handling \$10.00 ea.

15 East 31st Street
Kansas City, Missouri 64108
(816) 561-1776

We are 3 years old, and have close to 100 members.

1. **The Birmingham Microprocessor Group (BMG)**
 2. 3548 Stonehenge Pl, Birmingham AL 35210
 3. South Side library
 4. Fourth Sunday of each month at 2 PM
 5. *The Printout*
 6. Tom Bowen
 7. Home (205) 956-9576 Business (205) 870-1367
 8. \$6 per year
 9. The BMG is a general interest organization with special interest as follows: Apple Corp — Apple II owners and users; TRS-Can—TRS-80 or Radio Shack Users; Hardware Hackers — Homebrew.
 10. We currently have 116 members on the books with 25-30 being active participants in the general interest area and another 25 that are active in special interest activities.
1. **Central Alabama TRS-80 Computer Society**

2. c/o Lewis E Garrison, Secretary, 6375 Pinebrook Dr, Montgomery AL 36117
3. Normandale Community Center
4. Third Tuesday of each month
5. None
6. Lewis E Garrison or Walter Bray
7. (205) 272-8462 or (205) 272-3621 respectively
8. \$2 per month or \$24 per year
9. TRS-80

Zips 40000-50000

1. **Amateur Computer Society of Central Ohio**
 2. 2589 Brookwood Rd, Columbus OH 43209
 3. Center of Science and Industry
 4. First Wednesday of each month
 5. I/O
 6. Fred Hatfield K8VDU
 7. (614) 888-9287
 8. \$10 per year
 9. Personal networks, computer chess, and graphics.
1. **Akron Digital Group**

2. 107 7th St NW, Barberton OH 44203
3. Kenmore Public Library, 2200 14th St SW, Akron OH
4. Fourth Wednesday of the month at 7 PM
6. Lou Laurich
9. The club programs are planned toward the small systems hobbyist with tips on programming and hardware application.

1. **Goodyear Computer Club**
2. c/o J F Derry D-109E PLT1, Goodyear T and R Co, Akron OH 44316 I McLeod or R Flower D-471 G3, Goodyear Aerospace Corp, Akron OH 44315
3. Goodyear Hall
5. *The Late Edition*
6. J F Derry or R Flower
7. (216) 794-4010 or (216) 794-3573 respectively
8. \$10 per year
9. Hardware - modem design and building etc; investment analysis; new hardware/software developments; and education.
10. Personal computers used

by members: TRS-80, Apple, OSI C28P, IMSAI, KIM, PET, Homebrews, North Star Horizon, RCA 1802, and M-6800. Have had joint meetings with Akron chapters of the Association of Computing Machinery (ACM) and the Institute of Electrical and Electronic Engineers (IEEE) Computer Society.

1. **Alliance Micromputer Club**
 2. 3885 Norwood Ave, Alliance OH 44601
 3. Harter Bank Community Room
 4. First Tuesday of each month at 7 PM
 5. None
 6. Gary S Fix, President
 7. (216) 823-8996
 8. None
 10. About 20 members currently with about half owning a personal micro-computer system including several TRS-80s.
1. **Dayton Microcomputer Association**
 2. c/o Dayton Museum of

WHAT'S IT?TM

(Wow! How'd All That Stuff get In There?)

from Computer Headware
... the Self-Indexing Query System
for your Apple II, North Star, or CP/M machine

Distributed by:

- Information Unlimited / 219-924-3522
P.O. Box 8372, Merrillville, Indiana 46410
- Lifeboat Associates / 212-580-0082 (CP/M model only)
2248 Broadway, Suite 34, New York City 10024
- Structured Systems Group, Inc. / 415-547-1567
5208 Claremont Avenue, Oakland, California 94618



CONTROL PROGRAM FOR MICROCOMPUTERS NOW BETTER THAN EVER

You've probably heard about CP/M. But if you haven't, it's the world's most popular operating system. CP/M is considered the "software bus" for 8080 and Z80 microcomputers because it gives you the hardware-independent interface you need to make your computer work for you. Because it's hardware-independent, you can get programming languages, word processing software, and business applications packages from scores of suppliers at affordable prices.

CP/M 2.0 is the latest in the evolution of a proven reliable and efficient software system. It's the kind of reliability that comes from five years of field testing in thousands of installa-

tions. And it's supported by an experienced staff dedicated to maintaining CP/M as the best product in the industry.

CP/M 2.0 gives you many new features, with an enhanced upward compatible file system, powerful new random access capabilities, and unprecedented field alteration facilities which allow you to tailor CP/M 2.0 to manage virtually any disk subsystem. From minidisks, floppy disks, all the way to high-capacity hard disks, the flexibility of CP/M 2.0 makes it a truly universal operating system. Get yourself or your company on the software bus: contact us for further details, or ask your dealer about CP/M 2.0 availability for your computer.

DISKETTE and DOCUMENTATION
Single Quantity Prices: \$150



MULTI-PROGRAMMING MONITOR NEW INDUSTRY STANDARD

Digital Research announces a deluxe operating system that provides big computer facilities at small computer prices. MP/M is a monitor program which operates with your microcomputer to provide multi-terminal access with multiprogramming at each terminal. Best of all, it's CP/M compatible which means you can run a wide variety of programming languages, applications packages, and development software.

If you want, you can run simultaneous editors, program translators, and background printer spoolers. Or you can use MP/M for data entry or data-base access from remote terminals. Or you can use MP/M real-time features to monitor an assembly line and auto-

matically schedule programs for execution throughout the day. MP/M makes an excellent focal point for a cluster of connected microcomputers. The possibilities are limitless.

Like CP/M, MP/M is especially built to adapt to most 8080 or Z80 microcomputers, with an 8086 version on the way. You can operate your I/O devices either interrupt-driven or polled, and you can even write your own system processes which are combined with MP/M through a simple system generation. It's an exciting new product from the most experienced systems software supplier in the microcomputer industry. Contact us for details, or ask your dealer about MP/M availability for your computer system.

DISKETTE and DOCUMENTATION
Single Quantity Price: \$300

 **DIGITAL RESEARCH**[®]

Post Office Box 579
Pacific Grove, California 93950
(408) 649-3896

- Natural History, 2629 Ridge Ave, Dayton OH 45414
- Same as above
 - Last Tuesday of the month at 7:30 PM
 - DMA Data Bus
 - Dan Watson
 - (513) 223-2348
 - \$10 dues
 - 8080 Users - First Sunday 1 PM - 274-1149; 6800 Users - First Tuesday, 7 PM - 435-9297; 6502 Users - First and Third Monday, 7:30 PM -426-7711; TRS-80 Users (DARSUG) - call for time and place -426-1601; Apple II Users -Second Wednesday 7:30 PM -223-2348.
 - A special session for novices is held at 6 PM immediately before the regular meeting on the last Tuesday of the month. All other special groups meet at various locations - call for information. Visitors always welcome.
- Evansville Computer Club
 - c/o National Sharedata Corp, POB 3895, Evansville IN 47737
 - Blind Association, Second Ave and Virginia
 - Second Wednesday of the month at 7:30 PM
 - Robert Heerdink
 - (812) 426-2725
 - The group is varied with interest in several types of microcomputers.
- Purdue University Computer Hobbyist Club (PUNCH)
 - Rm 67 Electrical Engineering Building, West Lafayette IN 47907
 - Rm 117 Mathews Hall
 - Mondays at 7 PM
 - None
 - John Eaton
 - (317) 742-8521
 - None at present
 - Various microcomputer systems; predominately M6800 users.
- Detroit Personal Computer Network
 - 13043 McNichols, Detroit MI 48219
 - Andrew Fellman
 - (313) 865-4374
- This organization was formed to help microcomputer users discover and exchange ideas on user projects, to promote business or financial gain, and for enjoyment.
- Educational Recreational Computer Club
 - c/o Paul Heimnick, 1415 Olmstead St, Owosso MI 48867
 - Salvation Army, 302 E Exchange St, Owosso
 - ERCC Newsletter (monthly)
 - Paul Heimnick, President
 - (517) 723-7602
 - Dues \$5 per year/\$2.50 subscription for 1 year
 - Emphasis on TRS-80 to help educate others about computing.
- Battle Creek Area Microcomputer Club
 - 8587 Q Dr N, Battle Creek MI 49017
 - Pennfield High School (above address)
 - Yes
 - Jeff Stanton
 - (616) 763-9685
- \$1 periodically (for stamps)
 - Mostly TRS-80 owners.
 - Club library open to members. 50c per program copying fee. Cassettes and diskettes are sold at a discount through the club. Meetings consist of short presentations on BASIC or machine language, some program swapping, and equipment and software demonstrations.
- Zips 50000-60000
- Eastern Iowa Computer Club
 - POB 164, Hiawatha IO 52233
 - REC building in Marion
 - The last Sunday of the month at 7 PM
 - Yes
 - Mark Bergemann
 - (319) 377-1959
 - \$10 per year
 - Just started bit-slice microprocessor special interest group with plans to build one sometime in the future.
 - Working on a club

SPECIALIZING IN QUALITY MICROCOMPUTER HARDWARE

INDUSTRIAL • EDUCATIONAL • SMALL BUSINESS • PERSONAL

BUILDING BLOCKS FOR MICROCOMPUTER SYSTEMS, CONTROL & TEST EQUIPMENT

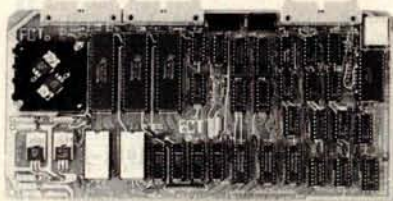

R² I/O
2K ROM
2K RAM
3 Serial Ports
1 Parallel Port
WIRED: \$295.00

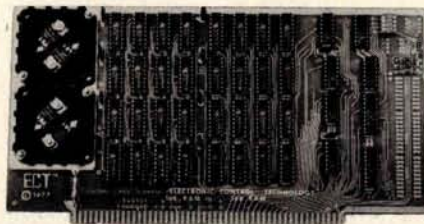

16 K RAM
FULLY STATIC
MEMORY
KIT: \$279.00
WIRED: \$310.00

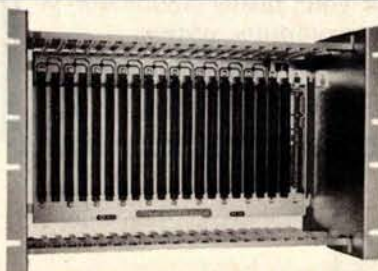

ECT-100-F
RACKMOUNT
CARD CAGES
KIT: \$200.00
WIRED: \$250.00

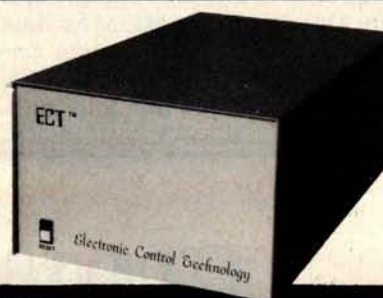

TT-10
TABLE TOP
MAINFRAMES
KIT: \$340.00
WIRED: \$395.00

POWER SUPPLIES, CPU's, MEMORY, OEM VARIATIONS

ELECTRONIC CONTROL TECHNOLOGY (201) 686-8080

763 RAMSEY AVE.
HILLSIDE, N.J. 07205

ONE PACKAGE DOES IT ALL

Includes these Application Programs . . .

Sales Activity, Inventory, Payables, Receivables, Check/Expense Register, Library Functions, Mailing Labels, Appointments, Client/Patient Records

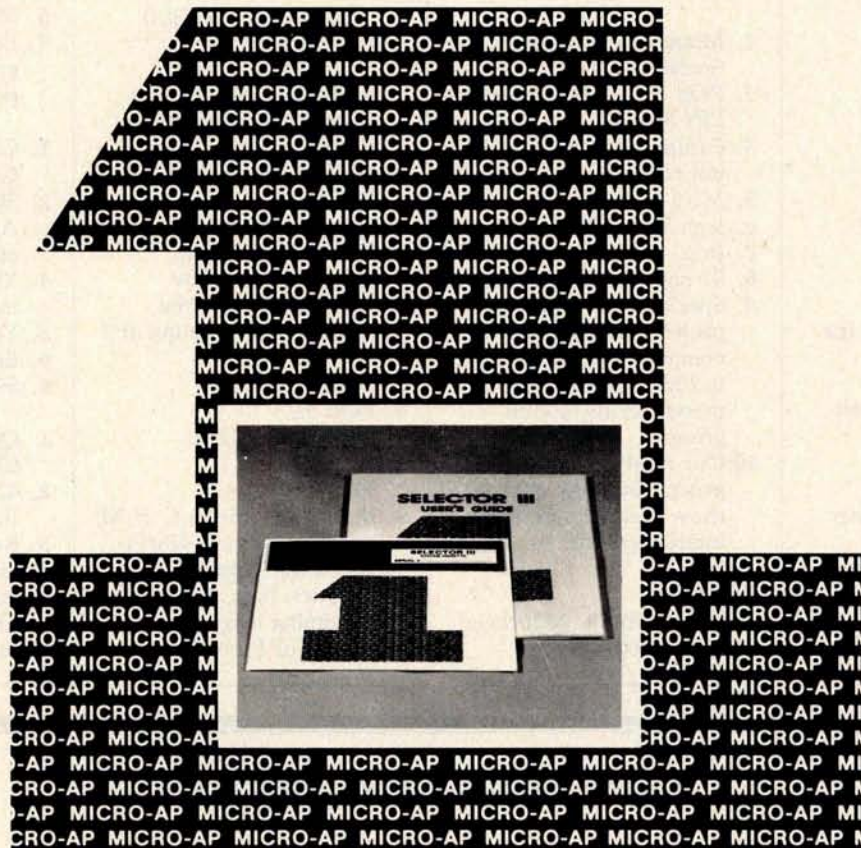

RANDOM, MULTI-KEY RECORD RETRIEVAL under CP/M, CDOS, IMDOS, ADOS . . .

SELECTOR III ALLOWS INSTANT RECALL OF ANY RECORD USING ANY INFORMATION ITEM IN THE RECORD. That statement deserves re-reading, because that ability makes SELECTOR III the most powerful Date Base Management System in micro-computers today!

With **SELECTOR III** you can...

- define a record format, assign retrieval keys, and begin entering data in minutes.
- create sorted pointers to records matching your specific or range of requirements.

- automatically generate reports with control-break summaries and unlimited variety.

- bring an application on-line in hours instead of months.

SELECTOR III comes complete with eight application programs that perform the tasks listed at top of page. And, since it's distributed in source code form, you can easily add subroutines to do specific computations or file updates.

SELECTOR III runs under CBASIC Vers. 1 or 2, and is priced at \$295. **SELECTOR**

III-C2 is dedicated to Vers. 2 only, runs about twice as fast, and costs \$345.

Both systems are available in a variety of CP/M, diskette size and density formats including IBM 8"; North Star; Micropolis; TRS-80; Processor Tech Helios II; Altair; iCOM; Dynabyte; Imsai; and others.

Available from computer stores nationwide:

LIFEBOAT Associates

2248 Broadway, Suite 34,
New York, N.Y. 10024 • (212) 580-0082

Or order direct from

MICRO-AP

9807 Davona Drive, San Ramon, CA 94583
(415) 828-6697

modem to use in a personal computer network.

1. Fox Valley Computer Society
2. POB 2742, Appleton WI 54913
3. Room D-104, Fox Valley Technical Institute
4. Second Tuesday of the month
6. Daniel K Dannells
7. (414) 734-7161
8. \$5 initially
9. Diversified.

1. Mini 'App'les
2. 13516 Grand Ave S, Burnsville MN 55337
3. Minnesota Federal Savings and Loan, Hopkins MN
4. Third Wednesday of the month
5. Mini 'App'les
6. Daniel B Buchler, President
7. (612) 890-5051
8. \$10 per year
9. Apple users group; user contributed program bank; monthly meeting and program; games; business; computer-assisted instruction; word-

processing; and documentation distribution.

10. Users group covers the twin cities of Minneapolis and St Paul metropolitan area. 'Local' members live roughly within a 100 mile radius. Newsletter subscribers are in all parts of the country.

1. Minnesota Computer Society
2. POB 35541, Minneapolis MN 55435
3. Future location to be announced
5. MCS Newsletter
6. Jean Rice
7. (612) 941-1051
8. \$7 regular; \$3 student
9. Special interest group projects; general interest computer presentations; technical presentations; presentations to civic groups.
10. Our meetings consist of general business speakers, show and tell, and special interest groups.
1. XXX-11
2. 514 So 9th St, Moorhead MN 56560

3. Moorhead MN
4. First and third Wednesdays of the month
5. XXX-11 Newsletter
6. C R Corner
7. (218) 233-7894
8. \$9 per year
9. Languages.

Zips 60000-70000

1. CACHE (Chicago Area Computer Hobbyists Exchange)
2. POB 52, South Holland IL 60473
3. Northern Illinois Gas Building, Golf and Shermer, Glenview
4. Third Sunday of the month, main meeting at 1 PM
5. CACHE Register
6. POB 52
7. Recorder on (312) 849-1132
8. \$10 per year
9. Business; TRS-80; C P/M; communications; Northstar; PET; Apple; LSI-11; robotics; ham; Pascal; programming languages (not BASIC or Pascal).

1. Microprocessor User Group
2. 641 Woodlawn, Aurora IL 60506
3. Fermi National Accelerator Laboratory, Hi-Rise, Main floor, SW meeting facility
4. Third Monday of the month at 8 PM
6. Mike Urso
9. Primarily an Apple user group, but we include all processors in discussions.

1. Chicago TRS-80 Users Group
2. 3950 N Lake Shore Dr, Apt 2310, Chicago IL 60613
4. Third Wednesday of the month
5. Yes
6. Emmanuel B Garcia-Jr
8. \$9 per year

1. QuadCity Computer Club
2. 4211 7 Ave, Rock Island IL 61201
3. Rock Island Arsenal
4. First Sunday of the month at 7 PM
5. QC³ News
6. John Greve

FOR THE VERY BEST IN

NORTHSTAR[®] COMPATABLE SOFTWARE

BUSINESS

CRS - Client Record System. A complete program package for the Insurance agent. CRS will provide you with very fast online access to your client records, print reports and mail labels, and give you all the information you will need to increase your sales through the use of CRS as a **MARKETING TOOL**.

CRS stores a complete record for each client that includes the name, address, telephone #, as well as provisions for customer #, salesman # and up to six policies (expandable if needed). The policy information is complete with both the type of coverage and the company that is underwriting it, as well as exp. date, premium, term, and payment schedule. You also have a remark field.

You can search the files by any field, and CRS supports a powerful 'sieve' search to provide you with all the information you need to increase insurance sales. CRS comes with two(2) users manuals, one for the owner, and one for office personnel (minimal system: one drive, 40K RAM starting 2000H) \$250.00 (manual: \$40.00)

TEXT PROCESSORS

TFS - Text Formatting System. At last a full featured text processor for NorthStar that you can rely on! TFS has left & right margin justification, page numbering, chaptering, page headings, centering, paged output & MORE. Supports powerful text manipulations including: global & local 'search and change,' file merges and block moves. This means that you can restructure your text file at any time to look the way you want it to, you can even 'chain' files together from disc for documents larger than your current memory.

TFS is completely 'load and go' therefore you can start using it at once. You get two(2) users manuals: one is a Quick Start manual to get you going in minutes, the other is an in depth study of TFS. (TFS requires RAM from 0000H to 2000H) \$75.00 (manual only: \$20.00)

ASSEMBLERS

ARIAN - A complete 8080 assembler that interfaces directly to your DOS. ARIAN is completely 'load and go'. Features include: dynamic file and RAM allocation, custom disc and RAM command capability, several library routines directly accessible by the user. Also, a complete text editor, and system executive. ARIAN is both powerful and easy to learn and use; it is an assembler that you can grow with. Comes complete with a 51 page users manual (ARIAN requires RAM from 0000H to 2000H) \$50.00 (manual alone: \$10.00)

ARIAN Utility Package - Several disc based utilities. Includes a complete DEBUG Package: \$50.00

PROGRAMMING LANGUAGES

'Tiny' PASCAL - This is the famous Chung/Yuen 'Tiny' PASCAL. FAST - ELEGANT - STRUCTURED. Local and global variables plus procedure and function independence make 'Tiny' PASCAL great for high speed applications. Compiles to 8080 code that executes up to 25 times faster than BASIC. You also receive SOURCE to 'Tiny' PASCAL written in PASCAL. This means that you can compile the compiler! Add features, relocate, etc. (you will need 36k to do this!) \$40.00

UTILITIES

D E B E - (Does Everything But Eat!) This is a must for NorthStar users. You can: COMPACT & EXPAND BASIC programs. Compacting removes unnecessary spaces and remarks. This saves memory and makes for programs run faster. Expanding puts them back again.

Cross-reference BASIC programs by variables and transfer statements.

Global substitutions of variable names in BASIC programs.

Formatted print outs of BASIC programs as well. \$40.00



**SPECIFY SINGLE OR DOUBLE DENSITY
ALL ORDERS PREPAID OR C.O.D.
ILLINOIS RESIDENTS ADD 5% SALES TAX**

SUPERSOFT
P.O. Box 1628
Champaign, IL 61820
(217) 344-7596

FROM THE ORIGINATOR OF THE TRS-80[®] PROJECT

PASCAL

UCSD Pascal, the powerful general purpose language system, developed for large and complex systems is now available for your TRS-80.

The FMG/UCSD Pascal system opens a new generation of value for your TRS-80. Package includes:

Operating System
Screen Editor
Z80 Macro Assembler
Library
Pascal Compiler
Utilities and System Reference Book
(Requires 48K system with 2 drives.)

Price \$150.00

Available without Macro Assembler
Linker and Library (for Run-Time use only)

Price \$100.00

MANUALS:

UCSD Reference Manual **\$25.00**
Problem Solving using Pascal **\$14.95**
(The beginner's book for UCSD Pascal)
Programming in Pascal **\$14.95**
Pascal Primer **\$17.95**

MICROSOFT BASIC

An extensive implementation of BASIC for the TRS-80 Z80 microprocessors. Its features are comparable to those of BASICs found on minicomputers and large mainframes. Requires TRS CP/M

Price \$110.00

TEXTWRITER II

Exclusively from FMG

A text formatting program that prints files created by an editing program. Contracts, personalized form letters and other documents can be printed from a stored library of standard paragraphs.

Spécially priced \$ 75.00

Regular Price \$130.00

Manual **\$ 25.00**

NEW TRS-80 COMMUNICATOR

RS-232 Communication Program allows the TRS-80 to transmit or receive programs or data files. Also makes the TRS-80 into a remote terminal. Requires Radio Shack RS-232 and CP/M

Price \$25.00

NEW Z80 SID Symbolic Instruction Debugger

Symbolic memory reference with built-in assembler/disassembler. Uses Z80 mnemonics.

Z80 SID Diskette and Manual **Price \$150.00**

CP/M OPERATING SYSTEM

New 1.46 Version

Includes RS-232 and I/O Byte implementation, Editor Assembler, Debugger and Utilities for 8080 and Z80 systems. For up to four TRS-80 floppy disks. Package includes:

CP/M System Diskette 5 1/4"
CP/M Features and Facilities Manual
CP/M Editor's Manual
CP/M Assembler Manual
CP/M Debugger Manual
CP/M Interface Guide

Price \$150.00

(Updates for 1.4 Version owners .. **\$ 15.00**)

(Requires 16K and one drive minimum)

Set of 5 Manuals **\$ 25.00**

Call or write for
Complete Information 



A Division of Applied Data Corporation

P.O. Box 16020 (B10), Fort Worth
Texas 76133 • (817) 294-2510

**Your exclusive dealer for
UCSD PASCAL and
TEXTWRITER II**

FMG for High Level Languages — BASIC — FORTRAN — COBOL & now PASCAL

CP/M is a registered trademark of Digital Research Corp.
TRS-80 is a registered trademark of Radio Shack

7. (309) 786-8187
 8. \$6 per year
 9. We cater to all brands of computers and deal with software and hardware.
1. St Louis Area Computer Club Inc
 2. POB 28924, St Louis MO 63132
 3. Thornhill Branch of St Louis County Library, Fee Fee and Willowyck Roads
 4. First Thursday of month at 7 PM
 5. SLACC Stack
 6. Noel Moss
 7. Days (314) 862-4040 or (314) 367-3189 evenings
 8. \$5 per year
 9. 8080 homebrew; modems; and data communications and networking; 1802 group; TRS-80 group; Pet group; and Apple group.
 10. Club serves as an information clearing house. Approximately 1/3 of the members own 6800 systems; the balance have other processors, especially 8080/Z80 and 650X.

Our meetings consist of club business, a formal presentation, and a rap session.

1. Silly-Corn Hills Computer Club
2. 2145 W Central Ave, Springfield MO 65802
3. Varies. 16 main meetings a year and section meetings
5. ASCII Code (Association of Computer Interested Individuals)
6. Andrew A Griffin, Secretary
7. (417) 866-2447 (8 to 4 PM central time)
8. Area computer users \$12 per year. Computer users outside SW MO and nonuser interested persons \$7 per year
9. All phases of computer use; relationship to computers in all phases of human life; 7 computer users groups; 9 computer applications groups (games to medical systems); 4 computer related interest groups (history, public access,

- programmable calculators, and grievance ombudsman). Broadly varied membership includes all types of users.
10. Plans for September 79 -September 80 membership year include: public ombudsman program for computer grievances; switched network, personal computing network; a computer fair at a local mall; ASCII Code to move from 6 to 12 issues annually; several programming schools; public access center; and a television program (in production!).

8. \$6 per year
1. The Computer Hobbyist Group of North Texas
2. 2405 Briarwood, Carrollton TX 76006
5. Printed Circuit
6. Warren Bean
8. \$7 per year
1. Alamo Computer Enthusiasts
2. 5411 Cerro Vista, San Antonio TX 78233
3. Norris Technical Center, Room 208, St Philip's College, San Antonio TX
4. Third Friday of the month
5. Yes
6. Dave Fashenpour
1. North American Computer Association
2. Suite 811, 1001 Main St, Lubbock TX 79401
3. Dallas TX
4. Second Friday of each month
6. Tom Crites
7. (806) 747-4119
8. \$200
9. Independent computer representatives. Must sell,

Zips 70000-80000

1. The Tulsa Computer Society
2. POB 1133, Tulsa OK 74101
3. Tulsa Vocational-Technical School 3420 S Memorial Dr
4. Last Tuesday of the month at 7:30 PM
5. The I/O Port

Creative Software Introduces: Programs & Products for the TRS-80 (16K level II)

1	NO	\$1600.00	CASH	EXPENSIVE REPAIRS
2	NO	\$1200.00	CHECK (NUMBER)	EXPENSIVE TIRE
3	CL	\$1400.00	CREDIT CARD	TRUNKS FOR THE BURE
4	CF	\$1300.00	CASH	BEATING BREAKING AND
				SWING
5	CD	\$1200.00	CHECKS	EXPENSIVE COLLEGE
6	FB	\$1100.00	CASH	BRINGING HOME THE
				BAZON
7	GI	\$1000.00	DEBTS & TRINETS	DEBTS THAT'S ALL!
8	HR	\$900.00	CREDIT CARD	NEW BORDS FOR THE
				BODS
9	TX	\$800.00	NUMBER CHECK	CONFISE THE I.R.S.
10	NO	\$700.00	TICKETS TO ALLEN	PAY OFF THE BOC FOR
				SERVICES RENDERED

TO CONTINUE, PRESS ENTER.

YOU SPENT THE FOLLOWING AMOUNTS IN EACH CATEGORY FOR THE MONTH OF APRIL 2001 - - -

AUTO	\$1600.00	TIRE	\$500.00
HOUSING/RENT	\$1500.00	TRUNKS	\$800.00
CLOTHES	\$1400.00	MEDICAL/DENTAL	\$700.00
ENTERTAINMENT	\$1300.00	INSURANCE PREMIUMS	\$600.00
EDUCATION	\$1200.00	SAVINGS	\$500.00
FOOD	\$1100.00	UTILITIES	\$400.00
GIFTS	\$1000.00	VACATION	\$300.00
HOUSEHOLD	\$900.00	MISCELLANEOUS	\$200.00

TOTAL AMOUNT SPENT WAS \$12000.00.
TOTAL TIRE WAS \$500.00.
DO YOU WANT TO SEE A SPENDING PROFILE FOR THIS MONTH? (Y OR N)

NEW! A super **JOYSTICK interface** for the **TRS-80!**
Three sockets allow you to use one Fairchild™ or two Atari™ joysticks with no modifications to the **TRS-80**. Joystick interface with two programs, separate power supply and instructions.

Only \$65.00
Joysticks (Fairchild™ or Atari™), each \$12.50

Household Finance I & II \$15.00

Part I: Inputs data on each household expenditure; lists, adds, updates, changes or deletes previously input items. Writes data to cassette tape. Part II: Reads data tape. Provides monthly and yearly summaries of financial data, single category summaries, and graphs a spending profile.

ALSO: New Programs for the PET:

PET Word Processor \$75.00

Complete word processing capabilities including upper/lower case, string search, string change and many other features found on commercial word processors. Package includes both text editor and formatter and requires 16K or 32K PET.

PET Space War II \$10.00

Fantastic real-time action! You are in complete control of the Enterprise as you fend off aliens to search the universe for colonizable planets. Requires the Creative Software single joystick for the PET.

PET Road Race \$10.00

Another great machine-language program gives you a choice of three different tracks as you battle with your opponent to finish the race. Includes oil slicks, automatic lap counters, and an elapsed time clock showing time to tenths of seconds.

Household Utility 1 \$12.00

(Includes Calendar, Loans and Buy or Rent Programs)

Household Utility 2 \$12.00

(Includes Compound Interest, Amortization and Car Costs Programs)

Many other **Creative Software** products are available for the **PET** and **TRS-80**. If your local dealer doesn't carry **Creative Software** products or program information, write directly to the address below. When placing an order please note:
Specify computer & program(s). Add \$1.50 shipping for each program ordered, \$2.50 for joystick interface. California residents add 6% sales tax. VISA/MASTERCHARGE accepted. Include card number and expiration date.

Creative Software

P.O. BOX 4030, MOUNTAIN VIEW, CA 94040

**Now!
For the
S-100 bus**

8086 Power

WITH 16-BIT WORD LENGTH

8086 CPU

This card brings state-of-the-art performance to the S-100 bus. It may be used to upgrade existing 8-bit systems by "swapping" the CPUs or it may form the foundation for a high performance 16-bit system. It will operate with 8-bit, 16-bit, or mixed memory and peripherals. It has a 1-megabyte addressing range. It can be factory upgraded at nominal cost from 4 Mhz. to 8 Mhz. when the faster CPU chip is available. Price — \$895.

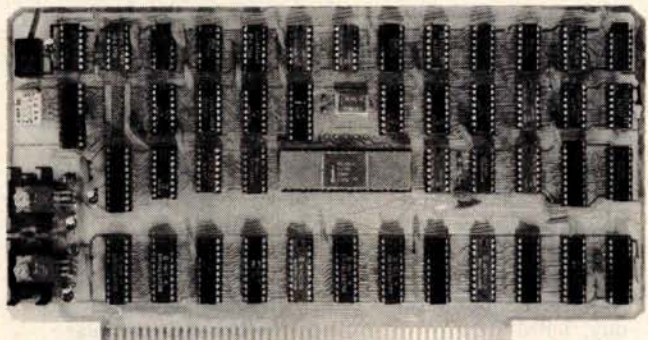

CPU Support Card

This is a companion to our 8086 CPU. It includes a 2K monitor with machine language debugger and disk bootstrap loader, serial port with software-selected baud rate, time-of-day clock with battery backup capability, two general purpose timers/counters, and a vectored interrupt controller with 7 interrupts generated on board and 8 accepted from the bus. Price — \$395.

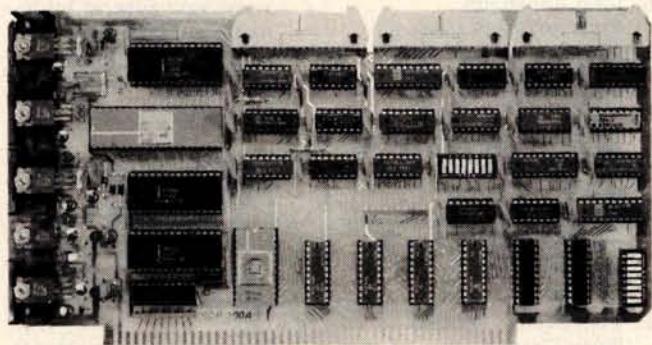

8/16 Memory Card

Through the use of the sXTRQ line of the proposed IEEE Standard, this memory board will appear to be 8K by 16 bits to our 8086 CPU or 16K by 8 bits to 8-bit CPUs. It is offered with 250 nsec. memory chips only and will perform without wait states with our 8086 CPU using an 8 Mhz. clock. It has 24-bit extended addressing. Price — \$595.

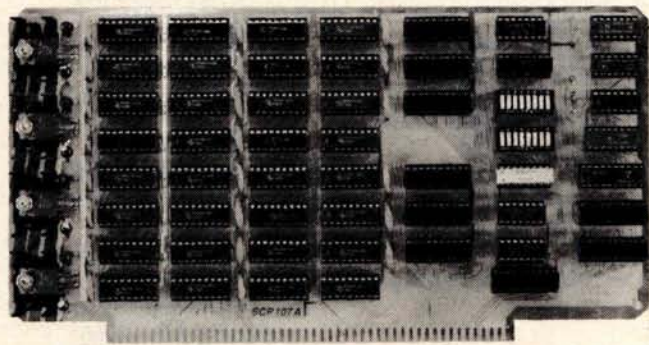

(Prototypes shown)

Z80/8086 Cross Assembler

This cross assembler runs under CP/M and its derivatives. Its mnemonics are the same as or similar to Intel's ASM-86. It is available in 5" soft-sectored, 5" North Star, or 8" soft-sectored (IBM) formats. Price — \$250.

Microsoft BASIC-86

Microsoft's BASIC interpreter for the 8086 is essentially identical in features to their 5.0 release for the 8080 and is ANSI compatible. It is a "stand-alone" version and includes all disk and terminal I/O drivers. Programs written for any earlier version of Microsoft BASIC will run under BASIC-86 with little or no modification. Price — \$350.

MCS-86 User's Manual

By Intel — Feb., 1979, edition. This is the primary hardware and software reference manual for the 8086 CPU. Price — \$6.25. (Includes shipping)

AVAILABLE NOW!

STOCK TO TWO WEEKS

**Call for more information
or the name of
our nearest dealer**



Seattle Computer Products, Inc.

1114 Industry Drive, Seattle, WA. 98188
(206) 575-1830

program, and service business systems.

1. **Permian Basin Computer Group**
2. c/o Ector School District, POB 3912, Odessa TX 79760
3. Midland Chapter: Student Union Building, Midland College. Odessa Chapter: Electronic Technology Building, Room 209, Odessa College.
4. Midland Chapter: monthly, the second Tuesday, 7:30 PM. Odessa Chapter: monthly, the second Saturday, 1 PM
5. None
6. John Rabenaldt
7. (915) 697-4607 (after 6 PM), (915) 332-9151 Ext 43 (9 AM to 5 PM)
8. No dues
9. Selectric interfaces, color displays, and MECA tape.
10. The Permian Basin Computer Group consists of 2 chapters.

1. **TRS Users - Permian Basin Group**
2. Rt #4, POB 1455, Odessa TX 79763
3. Rm 209, Electronics Technology Building, Odessa College
4. Second Saturday of the month at 1 PM
5. None
6. Allan D Emert
7. (915) 381-3138
8. None
9. Information and software exchange.

Zips 80000-90000

1. **Denver Amateur Computer Society**
2. 1380 S Santa Fe, Denver CO 80223
3. Same
4. Third Wednesday of every month. General board meeting - first Wednesday of every month.
5. *Interrupt*
6. Carl Grimes
7. (303) 759-8969
8. \$12 per year membership fee
9. Pascal, 6502, Z80/8080, CP/M, and TRS-80.

10. Annual Computer Show, called the "Computer Corral," at the Denver Merchandise Mart October 27th and 28th.

1. **Southern Nevada Personal Computing Society**
2. 1405 Lucilee St, Las Vegas NV 89101
3. Society Headquarters, 1405 Lucilee St
4. Second Saturday of each month at 12 noon
5. *Hard Copy* (monthly)
6. Cy Wells, President
7. (702) 642-0212
8. Corporate: \$12 per year; family: \$18 per year; corresponding: \$6 per year; student: \$3 per year
9. Both hardware and software; exchange of information and experience; and guidance and encouragement for the new hobbyist.

1. **Northern Nevada Computer Club**
2. c/o Mathematics Dept University of Nevada, Reno NV 89557
3. University of Nevada
4. (TBA)
5. *Meeting Announcements*
6. Professor Al Brady
7. (702) 784-6831
8. None
9. Personal computing and educational computing.

Zips 90000-99999

1. **San Fernando Valley 6502 Users Club**
2. 3816 Albrigh Ave, Los Angeles CA 90066
3. Computer Components Inc of Burbank, 3808 W Verdugo Rd, Burbank CA 91505
4. Second Tuesday of every month at 8 PM
5. *SFV 6502 Users Club Notes*
6. Larry Goga
7. (213) 398-6086
8. None at this time
10. The club is open to all owners of 6502-based computers including KIM, SYM, and AIM. PET and APPLE owners are also welcome. Formerly known as the San Fernando Valley KIM-1 Users Club.

1. **Compucolor and Intecolor Users Group**
2. 5250 Van Nuys Blvd, Van Nuys CA 91401
3. Same as above.
4. First Saturday of each month from 12 to 3 PM
5. *Users Bulletin* (quarterly)
6. Stan Pro
7. (213) 788-8850 10 to 6 PM weekly
8. \$25 per year; foreign add \$8
9. Business; games and graphic programs exchange; unpublished ports; poke positions and machine data; addition of peripherals to Compucolor and Intecolor; and machine updates.
10. International in scope.

1. **Ventura County TRS-80 Club**
2. 567 W Loop Dr, Camarillo CA 93030
3. Camarillo Public Library, 3100 Ponderosa Dr, Camarillo
4. First Tuesday of the month at 7 PM
5. Yes
6. Lee Steinmetz
7. (805) 484-1724
8. \$10 per year
9. The group's main purpose is to share information relating to the practical applications as well as the entertainment possibilities of the TRS-80.

1. **Homebrew Computer Club**
2. POB 626, Mountain View CA 94040
3. Fairchild Auditorium, Stanford Medical Center
4. Meeting dates are published in the club newsletter
5. *Homebrew Computer Club Newsletter*
6. Robert Reiling, President
7. (415) 967-6754
8. Donation requested
9. Information exchange on all systems and providing "vectors" to people and groups with similar interests.
10. A newsletter copy will be sent upon request, include a self-addressed stamped envelope. Anyone interested in computers is invited to attend Homebrew Com-

puter Club meetings.

1. **Apple Core**
2. POB 4816, San Francisco CA 94101
3. Homestead Savings, 22nd and Geary St, San Francisco
4. First Saturday of each month at 10 AM
5. *Cider Press*
6. Ken Silverman
7. (415) 878-5382
8. \$15 per year
9. Apple owners only.

1. **Pacifica TRS-80 Users Group**
2. 637 Brussels St, San Francisco CA 94134
3. Eureka Square Shopping Center
4. Second and Fourth Thursdays of the month
6. John F Strazzarino

1. **Solano TRS-80 Users Club**
2. 550 Marigold Dr, Fairfield CA 94533
3. Owens-Illinois, 2500 Huntington Dr, Fairfield CA
4. Third Thursday of the month
6. Steve Irwin
7. (707) 422-3347
9. Informal group that gets together to discuss mutual TRS-80 problems and experiences.

1. **ABACUS (Apple Bay Area Computer Users Society)**
2. Hayward BYTE Shop, 1122 B St, Hayward CA 94541
3. Same as above
4. Second Monday of the month
5. Yes
6. Ed Avelar, President
7. (415) 583-2431
10. Have an active membership of 40, and have developed a club library of 200-plus programs.

1. **RETUG (Redwood Empire TRS-80 Users Group)**
2. 7136 Belita Ave, Rohnert Pk CA 94928
3. Santa Rosa Computer Center
4. First Saturday of each month
6. John Revelle
7. (707) 545-2860
9. TRS-80s.

We Specialize in High Technology at Low Prices.



Econoram* boards are generally available in 3 forms: **unkit** (sockets and bypass caps are pre-soldered in place for simple, one-evening assembly), **assembled and tested**, or qualified under our high-reliability **Certified System Component (CSC)** program (200 hour burn-in, immediate replacement in event of failure within 1 year of invoice date). 1 year limited warranty on all products. Refer to chart below for pricing.



Name	Storage	Buss	Configurations	Notes	Unkit	Assm	CSC
Econoram IIA	8K X 8	S-100	2-4K blocks	1	\$149	\$179	\$239
Econoram IV	16K X 8	S-100	1-16K	1	\$269	\$329	\$429
Econoram VIIA-16	16K X 8	S-100	2-4K, 1-8K	1	\$279	\$339	\$439
Econoram VIIA-24	24K X 8	S-100	2-4K, 2-8K	1	\$398	\$485	\$605
Econoram IX-16	16K X 8	Dig Grp	2-4K, 1-8K	1	\$319	\$379	n/a
Econoram IX-32	32K X 8	Dig Grp	2-4K, 1-8K, 1-16K	1	\$559	\$639	n/a
Econoram X	32K X 8	S-100	2-8K, 1-16K	1	\$529	\$649	\$789
Econoram XI	32K X 8	SBC/BLC	2-8K, 1-16K	1	n/a	n/a	\$1050
Econoram XII-16	16K X 8	S-100	see notes	1, 2	\$329	\$419	\$519
Econoram XII-24	24K X 8	S-100	see notes	1, 2	\$429	\$539	\$649
Econoram XIII	32K X 8	S-100	see notes	1, 3	\$559	\$699	\$849
Econoram XIV	16K X 8	S-100	see notes	1, 4, 5	\$289	\$349	\$449
Econoram XV-16	16K X 8	H8	1-16K	1, 6	\$329	\$395	n/a
Econoram XV-32	32K X 8	H8	2-16K	1, 6	\$599	\$729	n/a

Notes:

1. Works at 5 MHz with 8085 or at 4 MHz with Z-80.
2. Bank select board — 2 independent banks addressable on 8K boundaries.
3. Bank select board — 2 independent banks addressable on 16K boundaries.
4. Bank select board — 1 bank addressable on 4K boundaries.
5. 24 address lines for extended addressing.
6. Bank select option for implementing memory systems greater than 64K.

*Econoram is a trademark of Bill Godbout Electronics.

Coming soon: This month, we're announcing the Econoram XIV with extended addressing, two new Econorams (XV-16 and XV-32) for the H8 buss, and our Memory Management Board. In the next few months, we'll be introducing...

- 4 MHz Z-80 CPU board
- 5 MHz 8085 CPU board
- Triple Parallel + Single Serial board, with 3 full duplex parallel ports and serial port with full RS-232 handshake
- 12 and 18 slot motherboards — double sided, shielded, and actively terminated
- And, a rack mount or desk top enclosure, with power supply, to hold all this neat stuff

Just thought you ought to know.

16K Memory Expansion Chip Set \$87.20 (regular \$109; 20% off while they last)

This Godbout quality product expands memory in Radio Shack-80, Apple, and Exidy Sorcerer computers. Our chip set features low power, high speed (250 ns) parts that work with 4 MHz systems. DIP shunts included. Easy-to-follow instructions for Radio Shack-80 modification make conversion simple. 1 year limited warranty.

"INTERFACER" S-100 I/O Bd \$189 unkit, \$249 assm

Dual serial port with 2 full duplex parallel ports for RS-232 handshake; EIA232C line drivers and receivers (1488, 1489) along with current loop (20 mA) and TTL signals on both ports. Onboard crystal-controlled timebase with independently selectable Baud rate generators for each part (up to 19.2 KBaud). This board has hardware LSI UARTs that don't tie up the computer's CPU, operates with 2 to 5 MHz systems, includes software programmable UART parameters/interrupt enables/handshaking lines, offers provision for custom frequency compensation on both receive and transmit sides to accommodate varying speed/noise situations or unusual cable lengths...and even all this isn't the full story on what this no-excuses board can do for you.

Econoram II Closeout \$129 unkit (3/\$375), \$155 assm

This is a limited quantity item. Our brand new Econoram IIA is out, but even by today's standards the original Econoram II is an excellent memory. 2 MHz operation, low power, configured as two independent 4K blocks, and one of the best track records in the industry for reliability and cost-effective operation. Easy one-evening assembly, 1 year limited warranty on all components.

18 Slot Motherbd Closeout — was \$124, now only \$109

Includes on-board active termination, with all 18 edge connectors pre-soldered in place for easy assembly. Limited quantity.

Memory Management \$59 kit, \$85 assm, \$100 CSC

Now you can add bank select and extended addressing to older S-100 machines like the IMSAI, Altair, Sol, Polymorphic, etc. Either use this board with our new extended addressing boards, or retrofit our high density Econorams (the ones with phantom or extra qualifier lines) for use with the Memory Management Board to get more than 64K of memory space for your computer.

2708 EROM board unkit \$85

4 independently addressable 4K blocks, with selective disable for each block. Built to CompuPro/Econoram standards (dipswitch addressing, top quality board, sockets wave-soldered in place), and includes dipswitch selectable jump start built right into the board. Includes all support chips and manual, but does not include EROMs.

ACTIVE TERMINATOR kit \$34.50

Our much imitated design plugs into any S-100 motherboard to reduce ringing, noise, crosstalk, and other buss-related problems. This is a simple, effective, low cost way to upgrade your machine.

SEE COMPUPRO™ AT A STORE NEAR YOU.

Many Godbout computer products are available under the CompuPro name at leading computer stores world-wide. Want to see for yourself exactly what kind of quality and effort we put into turning out cost-effective, high performance boards? Then see our products in person at a computer store near you.

TERMS: Cal res add tax. Allow 5% for shipping, excess refunded. VISA®/Mastercharge® call our 24 hour order desk at (415) 562-0636. COD OK with street address for UPS. Prices good through cover month of magazine.

CompuPro™ from **GODBOUT ELECTRONICS**
Bldg. 725, Oakland Airport, CA 94614

FREE FLYER: We'll be glad to tell you more than the space of this ad permits. Just send your name and address. We'll take care of the rest. If you're in a hurry, enclose 41c in stamps for 1st class delivery.

1. **68XX(X) Computer Club**
2. POB 18081, San Jose CA 95158
3. University of Santa Clara
4. Second Tuesday of each month
5. None
6. Ray Boaz
7. (408) 269-9522
8. None
9. All 68XX(X) microcomputers and related equipment. Latest developments in hardware and software for 68XX(X). Further the use of 68XX(X) computers in personal applications. Mutual aid in hardware and software problems.
10. Meetings are for the informal exchange of information. A software library is maintained for the common use of all.

1. **Sacramento Microcomputer Users Group**
2. POB 161513, Sacramento CA 95816
3. SMUD Training Facilities, 59th St
4. Fourth Tuesday of the month at 7:30 PM

5. *Push & Pop*

1. **Aloha Computer Club**
2. POB 4470, Honolulu HI 96813
3. Kaimuki Regional Library (usually)
4. Usually the second Wednesday of the month at 7:30 PM
5. *Debugga* (monthly)
6. Paul Lancaster or Gerry Cramm
7. (808) 235-3880 or (808) 254-2319, respectively
8. \$6 per year
9. Anything goes, as long as it is microcomputers.
10. Our users group meeting is followed by a short business meeting after which is a special presentation, then "mapping" and "random access."

1. **Apple Portland Program Library Exchange (A.P.P.L.E.)**
2. c/o Will Newman II, Secretary/Treasurer, 1915 N E Couch, Portland OR 97232
3. Varies
5. *Stems From A.P.P.L.E.*

6. Will Newman II
7. (503) 233-5711 (days and evenings)
8. \$2 application (one time) \$6 per year membership includes subscription (12 issues a year)
9. Wide variety of professional and hobby users. We trade programs and programming techniques and hold training classes (beginning to advanced) with local retailers.
10. Inquiries must be accompanied by a self-addressed, stamped envelope.

1. **Northwest Computer Society**
2. POB 4193, Seattle WA 98104
3. Seattle University Library Auditorium, Rm 115
4. First and third Thursdays of each month at 7:30 PM
5. *Northwest Computer News*
6. Roy Gillette, President, John Aurelius, Secretary
8. \$7 January thru December; \$10 June thru the

- 2nd December
9. Beginners, business, and hobbyists. Special sections: Tacoma chapter, TRS-80 group, and Heath H-8 group.
10. First meeting each month is formal with a speaker; the second meeting is informal.

1. **Apple Pugetsound Program Library Exchange**
2. 8710 Salty Dr NW, Olympia WA 98502
3. Rotates through various computer stores in the Seattle/Tacoma area
4. Third Tuesday of every month
5. *Call - A.P.P.L.E.*
6. Val Golding
7. (206) 932-6588
8. \$10 for 1979.

Newsletters

Zips 00000-10000

1. **Harvard Newsletter on Computer Graphics**
2. Harvard University

6800 SYSTEM SOFTWARE

Unmatched • Field Proven • Documented • Industry Wide

SDOS™

A totally interrupt-driven (both disk and other peripherals) disk operating system, including type-ahead. Provides device independent, byte addressable random files. Supports any mixture of disk drives up to 2.5 BILLION bytes per drive. Disk files can grow dynamically to match application needs. Automatic, overlapped read-ahead on sequential files and LRU sector buffer pooling on random-access files optimize disk I/O. System utilities allow operator file manipulation, disk initialization, backup with wildcard file selection, and disk structure repair facilities to handle the infrequent but unavoidable disasters that occur in the real world. Turn-key application systems can be easily built, coupled with SD Business Basic. 242 pages of documentation.

IDB

A RAM or EPROM-based assembly language debugger. Provides single-step with register display, multiple real-time conditional breakpoints, memory dump, multiple data display and entry modes. Can be used to debug interrupt-driven code. 39 pages of documentation.

6800 Hardware supported:

Conrac Model 480 (AMI MDC) + ICOM floppy
WaveMate + Persci floppy (1771 + DMA)
Electronics Product Associates + ICOM floppy
Motorola EXORcisor + EXORdisk I or II
SWTP + mini or DMAF floppy (FLEX)
CMI 6800 + Winchester (16M) + Calcomp floppy (1771 + DMA)
MSI 6800 + FD-8 mini-floppy or 10M cartridge disk
Mizar Labs + double density Micropolis drives (1791 + DMA)
SSB Chieftain—mini or 8-inch floppy
Computer and Data Machines (England)

BUSINESS BASIC COMPILER

A super fast application oriented BASIC. 10 digit BCD for values to 100 million dollars with pennies. Random access to variable size, variable content records. Long, meaningful variable names, formatted output, IF-THEN-ELSE with multiple statements per line, and error-trapping make this BASIC extremely powerful. Compiled code, automatic integer optimization, and fast floating point make applications written in SD Basic run faster than on virtually any other microcomputer, and protect the source code of the application. 104 pages of documentation.

EDIT

A powerful and easy to use text editor with change, delete, insert, and remove commands. Automatic display of text or context changes, macro facilities for complex or repetitive editing. 44 pages of documentation.

ASM

A lovely 2 pass assembler with conditional assembly, long labels, symbol table dump and cross-reference, error cross-reference, extensive arithmetic and listing control. 103 pages of documentation.

Write for a free catalogue or contact the hardware manufacturer.

All SD software comes with a 1 year warranty.

INNOVATION IN SOFTWARE



SOFTWARE DYNAMICS

2111 W. Crescent, Suite G
Anaheim, CA 92804
(714) 635-4760

Laboratory for Computer Graphics, 520 Gund Hall, Cambridge MA 02138

6. William Nisen
8. \$125 per year; \$45 for 9 issues
10. The newsletter monitors important commercial, technological, and product developments, as well as market, application and learning opportunities.
1. **Sorcerer Users Group**
2. 1395 Main St, Waltham MA 02154
3. None as of yet
5. *The Exidy Monitor*
6. Bruce R McGlothlin
7. (617) 899-4540
8. \$10 per year
9. The main purposes of the group are to make hardware and software developments known and available to the Sorcerer user, to supply software to the user, and to initiate an information service.
1. **Computers in Psychiatry/Psychology**

2. 26 Trumbull St, New Haven CT 06511
5. *Computers in Psychiatry/Psychology* (formerly *Micro-Psych*)
6. Marc Schwartz MD
7. (203) 562-9873
8. \$15 per year for membership and 6 issues of the 13-page newsletter
9. Clinical, research and interesting mental health uses of computers, office management, and administration. The newsletter contains articles, reviews, ongoing bibliography, psychology program catalog, training opportunities, job openings, and news of members' activities. Now publishing Vol. 2 of newsletter. Vol. 1 available for \$12.
1. **Physicians Microcomputer Report**
2. POB 6483
3. Lawrenceville NJ 08648
6. Dr Gerald M Orosz
8. \$25 per year; \$12.50 for students
9. Monthly publication for

doctors who wish to become better informed about the computer and its application in the field of medicine.

Zips 10000-30000

1. **Digital Group Independent Users Group**
2. POB 316, Woodmere NY 11598
5. *BRIDGE* (Bi-directional Reflections for the Illumination of Digital Group Enthusiasts)
6. Lloyd Kishinsky
8. \$10 for 10 issues of newsletter
9. A newsletter devoted to helping digital group users over the voids.
10. Newsletter published every 6 weeks. Vol. III starting in Fall '79. Newsletter includes helpful hints from users, items for sale, software exchange, applications, hardware and software fixes, Phideck special interest group, and articles submitted by members.

Membership is approximately 350.

1. **BUSS**
2. 325 Pennsylvania Ave SE, Washington DC 20003
5. *Buss: The Independent Newsletter of Heath Company Computers*
6. Charles Floto
7. (202) 544-0484
8. \$8.50 for 12 issues
9. Software and hardware compatible with computers made by the Heath Company.
10. Sample issue available upon request mentioning BYTE.
1. **ARESCO**
2. POB 1142, Columbia MD 21044
5. Four newsletters: *The Paper*, *VIPER*, *RAINBOW*, and *The Source*.
6. Rick Simpson or Terry Laudereau
7. (301) 730-5186
8. \$15 for 10 issues
9. *The Paper* - for owners of the Commodore PET. *The VIPER* - for owners

PROFESSIONAL



INCOME TAX PROGRAMS FOR TRS-80™

Accountants, lawyers, tax consultants nationwide, prepared over 30,000 1978 Federal tax returns using our system.

Displays and fills in Form 1040 and related schedules on the screen, then prints out the completed forms automatically.

Change your mind? Make an error? Correct a single entry and you have a brand new form with all re-computations made automatically.

No tax system, running on any computer anywhere, has all the features of our professional system, and yet—

Our base program, which does 1040 and Schedule A costs only \$189.95

And! You can add schedules for only \$37.95 each, customizing your system to your requirements.

CONTRACT SERVICES ASSOCIATES

706 SOUTH EUCLID

ANAHEIM, CA 92802

TELEPHONE (714) 635-4055

FREE CATALOG AND BROCHURE TO PROFESSIONALS



The Comprint 912 printer. No one else can match our speed, our print quality, our quiet operation, or our reliability. Not for \$660 they can't.

Our Comprint 912 is the best printer for the money. Period. Any printer that can match our price can't even begin to match our performance. And any printer that boasts performance like ours doesn't even come close to our price. No matter what your application; computer reports, listings, CRT hard copy, message

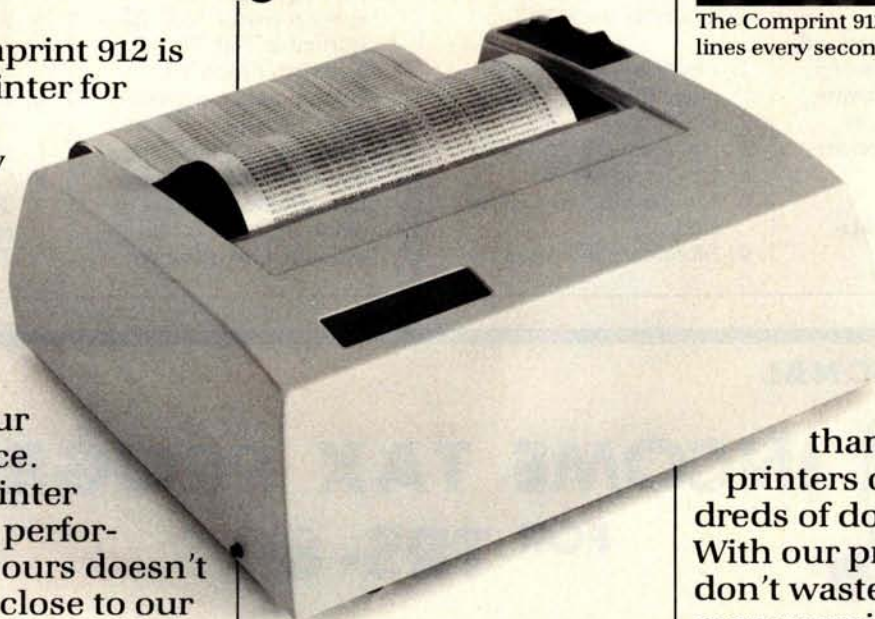

The Comprint 912 prints nearly 3 lines every second.

Speed.
At 225 characters per second (170 LPM) the Comprint 912 is up to 4 times faster

than impact printers costing hundreds of dollars more. With our printer you don't waste time and money waiting for your print-out.

Print Quality.

Our 9x12 matrix provides sharp, crisp characters. Compare that with our competition. Their very best is a 9x7 matrix, which means no lower case descenders and cramped letters. With the Comprint 912 you don't have to put up with the irritation of fuzzy, hard to read computer printing. This

receiving, scientific/ industrial data logging, or anything you can think of, the Comprint 912 is **the** performance leader in printers under \$1000.

First consider our performance.



CRT hardcopy is an excellent application for the Comprint 912.

exceptional print quality in
ly by the Comprint 912 in 7
nless reliability, 6 month
rallel I/O and 8 1/2" wide
been shipped to happy custo

The superior print quality provided
by the Comprint 912 is obvious in this
actual size sample.

means increased prod-
uctivity. And because
the Comprint 912 makes
better originals, our
originals make better
Xeroxes.

Quiet Operation.

Most computer
printers are irritat-
ingly noisy. They can
disrupt concentration
and reduce the effi-
ciency of anyone work-
ing near them. They're
noisy because they're

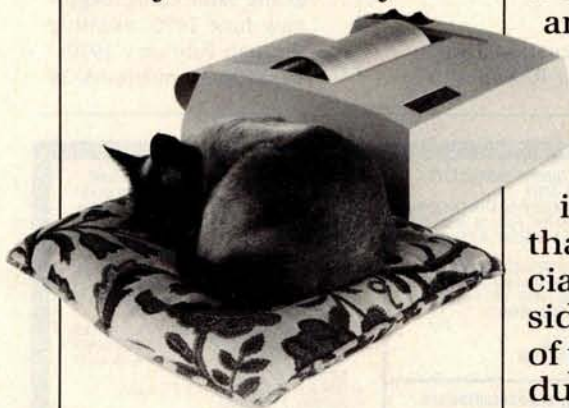

The Comprint 912 is quiet because it's
electronic not mechanical.

impact. The Comprint
912 has no mechanical
print head banging on
the paper. It's elec-
tronic. It's quiet.

Reliability.

Since the Comprint
912 prints electronically,
rather than mechan-
ically like ordinary im-
pact printers, we have
fewer moving parts and
less vibration. The
Comprint 912 has fewer
things to go wrong and
less wear. That's why we

offer a 6 month warrant-
ty, twice the industry
standard. The key to all
this superior perfor-
mance is our special

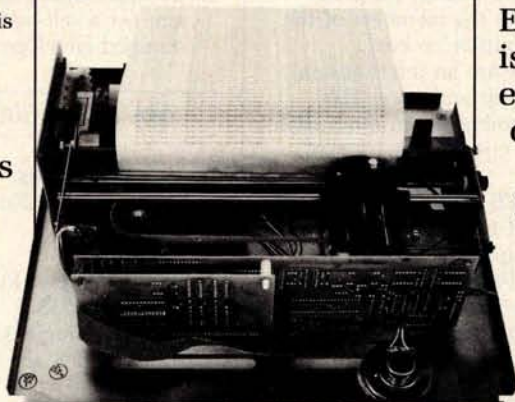

Fewer moving parts in the Comprint
912 mean greater reliability.

paper. This aluminized
"silver paper" works just
like ordinary paper. It
won't fade or discolor
and actually costs less
than plain paper and
one time ribbons. For
the vast majority of
printing applications
it's just plain better
than plain paper. Espe-
cially when you con-
sider the hidden costs
of plain paper printers
due to their inferior per-
formance compared to
the Comprint 912. And
on those rare occasions
when you really do

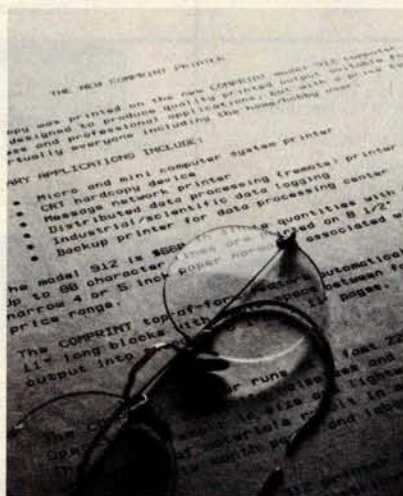

need a plain bond
paper copy, just run
your Comprint 912
printout through your
plain bond copy ma-
chine and you've got it.
Even though our paper
is special, it's available
everywhere; from your
dealer or distributor, or
from us.

Now consider our
price.

The Comprint 912.

\$660 with parallel
interface, \$699 with
serial interface.

We could talk about
our other advantages,
like our 80-character
lines on 8-1/2" wide pa-
per, or our compact,
light-weight size, and
the fact that the Com-
print 912 has no ribbons
to mess with, no chemi-
cals, nothing to add but
paper.

But you have to see
for yourself. Before you
buy any printer, insist
on seeing the Comprint
912, **the** performance
leader, at your local
computer store or in-
dustrial distributor. Or
contact us for a de-
scriptive brochure, a
sample print-out, and
applications literature.

comprint

The performance leader.

Computer Printers International, Inc.
340 E. Middlefield Rd.
Mountain View, California 94043
415 969-6161

- of the RCA VIP. *Rain-bow* - for owners of the APPLE II. *The Source* - for owners of the Exidy Sorcerer.
10. A subscription is for all 10 issues of one volume. Back issues are sent automatically.

1. Microcomputer Investors Association

2. 902 Anderson Dr, Fredericksburg VA 22401
3. As called
4. As called
5. *The Microcomputer Investor*
6. J Williams
7. (703) 371-5474
8. \$30 per year
9. An association of persons who utilize microcomputers to assist in making and managing investments.
10. Each participating member is required to publish one article per year in *The Microcomputer Investor*.

1. TRS-80 Users Group
2. 7554 Southgate Rd,

Fayetteville NC 28304

5. *TRS-80 Users Group Newsletter*
6. Mr Robert G Lloyd
7. (919) 867-5822
8. \$15 per year
9. To exchange programs with the members of the group at no cost.
10. We are an international group with over 1500 members from more than 20 countries.

1. TIPS Newsletter

2. 101 Brookbend Cr, Mauldin SC 29662
5. *TIPS Newsletter*
6. Fred Holmes
7. (803) 288-5664
8. \$3 for 4 issues
9. Support all microprocessor products produced by National Semiconductor from a hobbyist point of view, plus related semiconductor products from other companies. Microprocessors supported include IMP-16, SC/MP and INS 8070. Complete construction plans for microprocessor systems including I/O

(input/output) devices such as 24 by 80 video display, digital cassette and floppy disk. Also, system support software published.

10. Complimentary issue sent for a self-addressed stamped envelope.

Zips 30000-80000

1. 6502 User Notes

2. POB 33093, N Royalton OH 44133
5. Yes
6. Eric C Rehnke, Publisher
7. (216) 237-0755
8. \$13 for Volume 3 in N America, \$19 for Volume 3 elsewhere.
9. The newsletter supports KIM, SYM, AIM, and OSI 6502-based machines. We have special sections dealing with BASIC, Forth, FOCAL, Tiny BASIC, KIMSI, interface, music, etc.



1. **The International Institute for Robotics**

2. POB 615, Pelahatchie MS 39145

5. *Robotics Newsletter*
7. (601) 854-5339
8. \$8 for 12 issues
10. The newsletter solicits articles on all facets of robotics; we pay \$15 to \$50 per page for accepted articles. The Institute also offers free parts to hobbyists for articles; this is in addition to the payment above. The Institute also makes available a basic and an advanced course in robotics..

1. SR-52 Users Club (International)

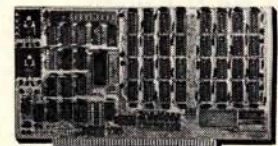
2. 9459 Taylorsville Rd, Dayton OH 45424
3. No meetings
5. *52-NOTES*
6. Richard C Vanderburgh
7. (513) 233-3698
8. \$1 per issue of *52-NOTES* (\$1.67 abroad, excluding Canada and Mexico).
10. Back issues are available at the same rates, beginning June 1976, monthly through February 1979. Texas Instruments-58/59

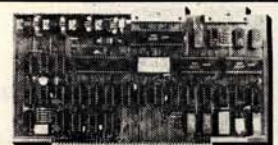
<p>6800, 64K BYTE RAM AND CONTROLLER SET MAKE 64K BYTE MEMORY FOR YOUR 6800 OR 6502. THIS CHIP SET INCLUDES: * 32 MSK 4116-3 16KX1, 200 NSEC RAMS. * 1 MC3480 MEMORY CONTROLLER. * 1 MC3242A MEMORY ADDRESS MULTIPLEXER AND COUNTER. * DATA AND APPLICATION SHEETS, PARTS TESTED AND GUARANTEED. \$325.00 PER SET</p>	<p>EPROM 2716-450NSEC \$49.00</p> 	<p>MOTOROLA MEMORY ADDRESS MULTIPLEXER—MC 3242A THE MC 3242A IS AN ADDRESS MULTIPLEXER AND REFRESH COUNTER FOR 16 PIN, 16K DYNAMIC RAMS THAT REQUIRE A 128 CYCLE REFRESH. * CONTAINS MEMORY REFRESH COUNTER. * MULTIPLEXES SYSTEM 14 BIT ADDRESS TO THE 7 ADDRESS PINS OF THE RAMS. * COMPATIBLE WITH 3480 MEMORY CONTROLLER. * PART IS GUARANTEED. \$12.50 EACH</p>	<p>KIM/SYM/AIM-65—32K EXPANDABLE RAM DYNAMIC RAM WITH ON BOARD TRANSPARENT REFRESH THAT IS COMPATIBLE WITH KIM/SYM/AIM-65 AND OTHER 6502 BASED MICROCOMPUTERS. * PLUG COMPATIBLE WITH KIM/SYM/AIM-65. MAY BE CONNECTED TO PET USING ADAPTOR CABLE. SS44-E BUS EDGE CONNECTOR. * USES +5V ONLY (SUPPLIED FROM HOST COMPUTER BUS). 4 WATTS MAXIMUM. * BOARD ADDRESSABLE IN 4K BYTE BLOCKS WHICH CAN BE INDEPENDENTLY PLACED ON 4K BYTE BOUNDARIES ANYWHERE IN A 64K BYTE ADDRESS SPACE. * BUS BUFFERED WITH 1 LS TTL LOAD. * 200NSEC 4116 RAMS. * FULL DOCUMENTATION * ASSEMBLED AND TESTED BOARDS ARE GUARANTEED FOR ONE YEAR, AND PURCHASE PRICE IS FULLY REFUNDABLE IF BOARD IS RETURNED UNDAMAGED WITHIN 14 DAYS.</p> <table border="1"> <thead> <tr> <th></th> <th>ASSEMBLED / TESTED</th> <th>KIT</th> </tr> </thead> <tbody> <tr> <td>WITH 32K RAM</td> <td>\$495.00</td> <td>\$450.00</td> </tr> <tr> <td>WITH 16K RAM</td> <td>\$425.00</td> <td>\$380.00</td> </tr> <tr> <td>WITHOUT RAM CHIPS</td> <td>\$355.00</td> <td>\$310.00</td> </tr> <tr> <td>HARD TO GET PARTS ONLY (NO RAMS)</td> <td></td> <td>\$180.00</td> </tr> <tr> <td>BARE BOARD AND MANUAL</td> <td></td> <td>\$65.00</td> </tr> </tbody> </table>		ASSEMBLED / TESTED	KIT	WITH 32K RAM	\$495.00	\$450.00	WITH 16K RAM	\$425.00	\$380.00	WITHOUT RAM CHIPS	\$355.00	\$310.00	HARD TO GET PARTS ONLY (NO RAMS)		\$180.00	BARE BOARD AND MANUAL		\$65.00
	ASSEMBLED / TESTED	KIT																			
WITH 32K RAM	\$495.00	\$450.00																			
WITH 16K RAM	\$425.00	\$380.00																			
WITHOUT RAM CHIPS	\$355.00	\$310.00																			
HARD TO GET PARTS ONLY (NO RAMS)		\$180.00																			
BARE BOARD AND MANUAL		\$65.00																			
<p>\$100 FULLY ASSEMBLED MOTHERBOARDS—FULLY SOCKETED, INDUSTRIAL GRADE * 8 SLOT ASSEMBLED \$149.00 * 19 SLOT ASSEMBLED \$199.00</p>	<p>VISTA V-200 MINI-FLOPPY SYSTEM * S100 DOUBLE DENSITY CONTROLLER * 204 KBYTE CAPACITY FLOPPY DISK DRIVE WITH CASE & POWER SUPPLY * MODIFIED CPM OPERATING SYSTEM WITH EXTENDED BASIC \$695.00 * EXTRA DRIVE, CASE & POWER SUPPLY \$395.00</p>	<p>MOTOROLA DYNAMIC MEMORY CONTROLLER—MC3480L MEMORY CONTROLLER DESIGNED TO SIMPLIFY CONTROL OF 16 PIN 4K OR 16K DYNAMIC RAMS. * GENERATES RAS/CAS AND REFRESH TIMING SIGNALS FOR 16K TO 64K BYTE MEMORIES. * GENERATES MEMORY READ/WRITE TIMING. * DIRECT INTERFACE WITH MOTOROLA OR INTEL 3242A ADDRESS MUX AND REFRESH COUNTER. * PART GUARANTEED. \$13.95 EACH</p>																			
<p>64K BYTE EXPANDABLE RAM DYNAMIC RAM WITH ON BOARD TRANSPARENT REFRESH GUARANTEED TO OPERATE IN NORTHSTAR, CROMEMCO, VECTOR GRAPHICS, SOL, AND OTHER 6800 OR Z-80 BASED S100 SYSTEMS * 4MHZ Z-80 WITH NO WAIT STATES * SELECTABLE AND Deselectable IN 4K INCREMENTS ON 4K ADDRESS BOUNDARIES. * LOW POWER—8 WATTS MAXIMUM. * 200NSEC 4116 RAMS. * FULL DOCUMENTATION. * ASSEMBLED AND TESTED BOARDS ARE GUARANTEED FOR ONE YEAR AND PURCHASE PRICE IS FULLY REFUNDABLE IF BOARD IS RETURNED UNDAMAGED WITHIN 14 DAYS.</p> <table border="1"> <thead> <tr> <th></th> <th>ASSEMBLED / TESTED</th> <th>KIT</th> </tr> </thead> <tbody> <tr> <td>64K RAM</td> <td>\$595.00</td> <td>\$565.00</td> </tr> <tr> <td>48K RAM</td> <td>\$525.00</td> <td>\$495.00</td> </tr> <tr> <td>32K RAM</td> <td>\$455.00</td> <td>\$425.00</td> </tr> <tr> <td>16K RAM</td> <td>\$385.00</td> <td>\$355.00</td> </tr> <tr> <td>WITHOUT RAM CHIPS</td> <td>\$315.00</td> <td>\$285.00</td> </tr> </tbody> </table>		ASSEMBLED / TESTED	KIT	64K RAM	\$595.00	\$565.00	48K RAM	\$525.00	\$495.00	32K RAM	\$455.00	\$425.00	16K RAM	\$385.00	\$355.00	WITHOUT RAM CHIPS	\$315.00	\$285.00	<p>16K X 1 DYNAMIC RAM THE MK4116-3 IS A 16,384 BIT HIGH SPEED NMOS. DYNAMIC RAM. THEY ARE EQUIVALENT TO THE MOSTEK, TEXAS INSTRUMENTS, OR MOTOROLA 4116-3. * 200 NSEC ACCESS TIME. 375 NSEC CYCLE TIME. * 16 PIN TTL COMPATIBLE. * BURNED IN AND FULLY TESTED. * PARTS REPLACEMENT GUARANTEED FOR ONE YEAR. \$9.50 EACH IN QUANTITIES OF 8</p>	<p>S100 MAINFRAME AND CARD CAGE</p>  <p>* W/ SOLID FRONT PANEL \$239.00 * W/ CUTOFFS FOR 2 MINI-FLOPPIES \$239.00 * 30 AMP POWER SUPPLY \$119.00</p>	
	ASSEMBLED / TESTED	KIT																			
64K RAM	\$595.00	\$565.00																			
48K RAM	\$525.00	\$495.00																			
32K RAM	\$455.00	\$425.00																			
16K RAM	\$385.00	\$355.00																			
WITHOUT RAM CHIPS	\$315.00	\$285.00																			
<p>BETA COMPUTER DEVICES P.O. BOX 3465 ORANGE, CALIFORNIA 92665 (714) 633-7280</p> 	<p>7-80 CPU • Z-80 CPU • Z-80 CPU • Z-80 CPU * 2MHZ OR 4MHZ SWITCH SELECTABLE * 2 SERIAL PORTS * 2 PARALLEL PORTS * SELECTABLE BAUD RATES 150-9600 * POWER ON JUMP TO ON BOARD 2708 OR 2716 EPROM (BOARD DELIVERED WITHOUT EPROM) \$325.00</p>	<p>CALIF RESIDENTS PLEASE ADD 6% SALES TAX. MASTERCHARGE & VISA ACCEPTED. PLEASE ALLOW 14 DAYS FOR CHECKS TO CLEAR BANK. PHONE ORDERS WELCOME.</p>	<p>TRS-80 16K MEMORY EXPANSION KIT THIS KIT PROVIDES THE IC'S TO EXPAND THE TRS-80 MAINFRAME FROM 4K BYTES TO 16K BYTES OR MAY BE USED IN THE EXPANSION CHASSIS. THE KIT INCLUDES: * 8 MSK 4116-4 16K X 1, 200 NSEC RAMS. * 1 DIP PROGRAMMING SWITCH. * 1 SET OF EASY TO FOLLOW INSTRUCTIONS THAT ONLY REQUIRES A SCREWDRIVER TO SUCCESSFULLY COMPLETE THE INSTALLATION. \$80.00 PER KIT</p>																		

GO FROM THIS . . .

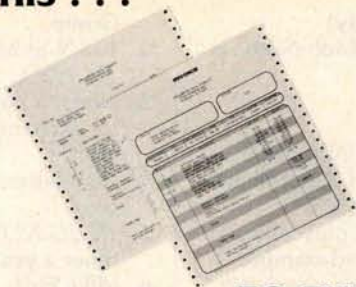

GOFORMS

STOCK CONTINUOUS BUSINESS FORMS

TO THIS!

Just Program and Go!

- You can produce commercial quality output in a few short minutes with our "off-the-shelf" blank heading forms.
- Simply program your company information and run.
- Software dependent format allows for easy modification of information.
- Multiple company or multiple division output is easily accomplished on a single printer without changing forms.
- Excellent for systems houses and software dealers.
- Full size 8 1/2 x 11 format provides large work space and is compatible with letter size files.
- Window position for standard commercial number 10 envelopes.
- Half-inch grey bars for easy readability.

INVOICE

INVOICE
3 PART #1013

STATEMENT

STATEMENT
3 PART #1023

PURCHASE ORDER

PURCHASE ORDER
3 PART #1033

ORDERING INFORMATION

Packed 1,000 to a carton
Suggested list price: \$79.00 per 1,000

Minimum order to qualify for dealer discount: 5,000 (may be assorted).

TERMS

Initial order C.O.D.

Shipping weight 35 pounds per 1,000
F.O.B. Valencia, CA

Units may be purchased in any combination of 1,000's

GOFORMS

BOX 55247 . VALENCIA, CA 91355

© Copyright 1979 Circle 151 on inquiry card.

coverage began June 1977.

1. **The Target-an Aim 65 Newsletter**
2. RR#2, Spencerville OH 45887
5. *The Target-an Aim 65 Newsletter*
6. Donald Clem
7. (419) 647-6576
8. \$5 in US and Canada, \$12 elsewhere
9. The newsletter is for present and future Rockwell Aim 65 users. The Aim is built around the 6502 microprocessor, so the information is useful for all 6502s. The newsletter contains software and hardware usable with the Aim.
10. The newsletter is published bimonthly. Six issues a year per subscription. Past issues have contained articles on the printer, the display, power supplies, product reviews, as well as other information.

1. **Apple Library**
2. 51625 Chestnut Rd,

Granger IN 46530

3. Mail only
5. No
6. Joe Torzewski
7. (219) 272-4670
8. None
9. Support of Apple computer.
10. Send self-addressed stamped envelope, please.
1. **Mid-Michigan Computer Club**
2. 9274 Marinus Dr, Fenton MI 48430
3. No scheduled meetings
5. None
6. Tony Preston
7. (313) 629-0363
8. None
9. Games, artificial intelligence, and operating systems.

1. **The Target**
2. Custom - Tronics, POB 4310, Flint MI 48504
8. \$15 per year
10. Bimonthly newsletter for owners or prospective owners of Aim 65 systems.

1. **SCAMPUS (SC/MP**

Users Society)

2. POB 132, Knob Noster MO 65336
3. None
4. None
5. *SCAMPUS Newsletter*
6. Tom Bohon, Coordinator
7. (816) 563-2650
8. \$2 per year plus large, self-addressed stamped envelopes for newsletter mailings
9. Composed of members who are interested in or actually building systems based on the National Semiconductor SC/MP-II processor.
10. All members have access to a growing library of both articles and programs for cost of reproduction and postage. The newsletter is approximately monthly. Current newsletter is available to interested parties for large, self-addressed stamped envelope. Group is trying to design a project computer for interested members to build.

1. **Theater Computer Users**

Group

2. 104 N St Mary, Dallas TX 75214
3. None, a national group for exchange of information.
4. Newsletter, 4 times a year.
5. *TCUG NOTES* about 4 times a year
6. Mike Firth
7. (214) 827-7734 days or evenings.
8. \$4 to cover costs of 4 issues of the newsletter (about a year).
9. The uses of computers in live drama (theater) operations such as light control, administration, design, and sales.

Zips 80000-90000

1. **COSMAC Users Group (CUG)**
2. POB 7162, Los Angeles CA 90022
3. Local chapters may be formed in the future
5. *The 1802 Peripheral*
6. Patrick Kelly, Director
7. Inquiries to above address; please include self-

CGS-808 INTELLIGENT COLOR GRAPHICS

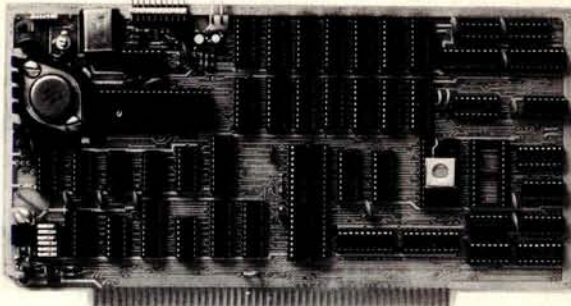

The CGS-808 is an intelligent color graphics board for the S-100 bus. With its own on-board microprocessor, the CGS-808 can plot points, draw lines and circles, generate upper/lower case characters, as well as custom character sets — all in color.

Not only is the CGS-808 simple to use, just plug it in and run — it requires no memory space and little software overhead. It has its own parallel I/O port to interface directly with keyboards, joysticks, light pens or digitizers. Call or write for a free brochure.



BIOTECH ELECTRONICS
P.O. Box 485, Ben Lomond, CA 95005
(408) 338-2686

Features:

- Motorola MC6847 video display generator.
- On-board 8085 microprocessor.
- Eight colors — green, yellow, blue, red, buff, cyan, magenta, orange.
- 11 programmable modes.
- 1 alphanumeric mode with 32 x 16 characters and inverse video.
- 2 semigraphic modes with 8 colors in 64 x 32 and 64 x 48.
- 8 full graphic modes with 2 sets of 4 colors ranging from 64 x 64 to 128 x 192, and 2 sets of 1 color in 256 x 192.
- I/O mapped for true S-100 compatibility.

CGS-808B (Bare "kit") \$ 99.00
(includes PC board, documentation, MC6847, MC1372, 8085 and 2708 with graphic driver subroutines)

CGS-808A (Assembled & Tested) \$385.00
Firmware Pack II \$ 99.00

Phone Orders Welcome — Visa/Mastercharge
Add \$3.00 for Shipping and Handling.
California Residents Add 6% Sales Tax.

NEW

T.D.Q. TAPE DATA QUERY

PET-8 K

TRS-80-LEVEL II

***FILE MANAGEMENT SYSTEM**

—UTILIZES DUAL AUDIO CASSETTE RECORDERS

***INTERACTIVE QUERY LANGUAGE**

—ENGLISH-LIKE COMMANDS

—POWERFUL INFO RETRIEVAL CAPABILITY

***COMPUTERIZED BUSINESS & PERSONAL RECORDS**

—CUSTOMIZE YOUR OWN FILE STRUCTURES

—CREATE & MAINTAIN DATA FILES

—NO PROGRAMMING EXPERIENCE REQUIRED

***IMPLEMENTED IN BASIC**

T.D.Q. CASSETTE WITH MANUAL & REF. CARD \$50.00

THE FOLLOWING PRE-DEFINED T.D.Q. FILE STRUCTURES ARE AVAILABLE TO SOLVE YOUR DATA PROCESSING NEEDS:

INVENTORY CONTROL	\$35.00
ACCOUNTS RECEIVABLE	\$35.00
ACCOUNTS PAYABLE	\$35.00
ORDER PROCESSING	\$35.00
CUSTOMER DIRECTORY	\$25.00
APPOINTMENT SCHEDULING	\$25.00

EACH WITH CASSETTE AND MANUAL

SEND SELF-ADDRESSED STAMPED ENVELOPE FOR COMPLETE SOFTWARE CATALOGUE. SEND CHECK OR MONEY-ORDER TO:

H. GELLER COMPUTER SYSTEMS
DEPT. B, P.O. BOX 350
NEW YORK, NY 10040

(NEW YORK RESIDENTS ADD APPLICABLE SALES TAX)

'TINY' PASCAL

for **TRS-80®**

& **NORTH STAR®**

Now you too can have Pascal! The Chung/Yuen 'Tiny' Pascal has been specially designed for TRS-80 & North Star owners. The full power & elegance of 'Tiny' Pascal is at your command. Programs written in 'Tiny' Pascal run at least 4 times faster than the same program in BASIC! 'Tiny' Pascal is also a great way to learn Pascal Programming, & fun too.

The minimum system requirements are: Level II, 16K for TRS-80, (no disk required) & 24K for North Star (specify density).

SOURCE TOO!

But most important, you also get source to 'Tiny' Pascal written in Pascal with each purchase! You can even compile the compiler! (Requires 36K for North Star systems, & 32K, Level II for TRS-80). You can customize your own version, or just use it the way it is.

'Tiny' Pascal is a subset of Standard Pascal & includes:

RECURSIVE PROCEDURE/FUNCTION, IF-THEN-ELSE,
REPEAT/UNTIL, 'PEEK & POKE', WHILE, CASE, & MORE!

(Plus full graphics for TRS-80 as well)

Also you can save & load programs.

You get all this & more, plus a user's manual for \$40.00.

available from:

SUPERSOFT

P.O. Box 1628
Champaign, IL 61820
(217) 344-7596

All orders pre-paid, Illinois residents add 5% sales tax

TRS-80 disk software

DISKETTE DATA BASE IDM-III 32K \$49

You can use it to maintain a data base & produce reports without any programming. Define file parameters & report formats on-line. Features key random access, multi-keys, sort, select, field arith, audit log. Almost use up all 32K.

ACCOUNT manage client accounts & account receivable. Automatic billing & transaction recording. Print invoices and reports. 32K req. \$59.

WORD PROCESSOR 16K \$39

Our WORD-III is the first word processor specifically designed for TRS-80 that uses disk storage for text. Written in BASIC. No special hardware and text limit. Use for letters, manuals & reports.

MAILING LIST 16K \$35

It lets you maintain data base and produce reports & labels sorted in any field. Random access. 2-digit selection code used.

INVENTORY 16K \$39

While others use inefficient sequential file, we use 9-digit alphanumeric key for fast on-line random access. Record has key, description, level, safety level, order amt., unit cost & price, annual usage, location and vendor code. Reports give order info, performance summary, etc.

KEY RANDOM-ACCESS UTIL 16K \$19

Lets you access a record by specifying a key. Features hashing, blocking, buffering technique, auto I/O error retry, etc.

MICRO ARCHITECT
96 Dothan St.
Arlington, MA 02174

TRS-80 . . . all business! ! ...with CP/M, CBASIC2, & applications software.

CP/M Operating System (w/Editor, Assembler, Debugger, Utilities & 6 manual set)	\$150
CBASIC2 Compiler (w/manual)	\$ 95
DESPOOL Print Spooler (w/manual)	\$ 75

*Osborne & Assoc. PAYROLL W/COST ACCTNG	\$250
*Osborne & Assoc. ACCTS. RECEIVABLE & ACCTS. PAYABLE	\$250
*Osborne & Assoc. GENERAL LEDGER.	\$250

*CBASIC2 source programs; add \$15 (each) for applicable O & A book.

APH - Self-administered Automated Patient History. \$175

DOWNLOAD - TR-80 (or other) CP/M to CP/M. \$ 95
data/program (source or object) transfer over RS232 link

Send 30¢ SASE for add'l. Software avail. (including CP/M Users Group software) and FREE "CP/M Primer." CA residents add 6% tax. Visa, M/C, M/O, Check OK.



(714) 848-1922

8041 NEWMAN AVENUE • SUITE 208 • HUNTINGTON BEACH, CALIFORNIA 92647

- addressed stamped envelope.
- Membership is free; subscription to newsletter is \$5 for 12 issues (minimum 8 pages, each). All subscriptions must start with Volume #1, Issue #1.
 - The CUG is a user's group for all 1802-based microcomputers, including Basic ELF, ELF-II, Super-ELF, UC-1800, DSD-1802, VIP, homebrews, etc.
 - The CUG is a nonprofit, national syndicate of 1802-based computer owners and users. Our members provide copies of their own software and hardware to other CUG members, charging only for actual copying and postage costs. Each member receives a detailed listing in our newsletter, which publishes both software and hardware articles and reviews.
- Poly 88 Users Group**
 - 1477 Barrington #17, Los Angeles CA 90025
 - None
 - Poly 88/Poly 8813 Users Group Newsletter*
 - Pat or Roger Lewis
 - (213) 477-8478 after noon
 - \$5 US and \$15 foreign for 12 issues
 - Software exchange or hardware tips.
 - \$2.50 for programs without trade. \$2 for cassette. \$3 for disks.
- Business Computing Press**
 - POB 55056, Valencia CA 91355
 - Business Computing Newsletter*
 - Alan Bartholomew, Publisher, Greg Scott, Editor
 - (805) 255-8543 or (213) 881-8076 respectively
 - Newsletter - available free at computer stores.
- Computer Information Exchange**
 - POB 158, San Luis Rey CA 92068
 - None
 - TRS-80 Bulletin, TRS-80 Computing*
 - Bill McLaughlin, Editor
 - (714) 757-4849
- Bulletin free, *TRS-80 Computing 2* for \$15
 - TRS-80 uses.
- PROTEUS, The Processor Technology Users Society**
 - 1690 Woodside Rd, Suite 219, Redwood City CA 94061
 - Various chapters throughout USA and Canada
 - PROTEUS/News* (bimonthly, equivalent to 48 pages per issue)
 - Stan Sokolow
 - (415) 368-3331
 - \$12 in USA, \$15 in Canada or Mexico, \$20 elsewhere (US funds only, please)
 - A balance between hobbyist and commercial interests: tutorial articles, hardware reviews, software reviews, news, group discounts, program library, tape recorded lectures, and communication among members.
 - Formerly known as Solus, we are now open to anyone owning a Sol, CUTS, or Helios, or any
- compatible hardware. Send \$2 for a sample issue of the newsletter.
- Cromemco User Systems and Software Pool (CUssP)**
 - POB 784, Palo Alto CA 94302
 - Locally arranged
 - CUssP Newsletter*
 - David Dameron
 - (415) 321-5998
 - \$10 for 3 issues; \$12 outside USA, Canada and Mexico
 - Users of Cromemco computers and boards.
 - The purpose of CUssP is the exchange among users of operating notes, hardware and software modifications, user written software, evaluations, and Cromemco announcements.
- LISP Users Newsletter**
 - 18215 Bayview Dr, Los Gatos CA 95030
 - John R Allen
 - This newsletter is designed to spread information about applications, implementation and general

Get in touch with the REAL WORLD

The world of temperature, velocity, moisture, water level, darkness and light, magnetic fields, pressure, the presence or absence of people or objects, amplifiers, analog memories and mathematical functions

with more practical applications than you can imagine!

Most Q-kit functions stand alone. When used as a peripheral, will make more efficient use of your microcomputer - any microcomputer!

Qkit - if you're willing to build your own

Qmod - assembled kits for office or industry

Qe.d. - expanded theory and instruction for the field of education

Qkit P.O. BOX 35879
602-299-9831
TUCSON, AZ 85740

ANALOG FUNCTIONS
... in touch with reality

Write for your free catalog!
Dealer Inquiries Invited
a division of J.R. Conwell Corporation



**CY-480
UPC™:
THE WORLD'S
ONLY SINGLE CHIP
LSI UNIVERSAL PRINTER
CONTROLLER! ONLY \$35.00**

The CY-480 UPC™ ... providing the kind of service and special features others don't!

And that means for off-the-shelf low prices, the CY-480 provides great flexibility and easy interfacing. Cybernetic Micro Systems' amazing CY-480 will control and interface standard 5" x 7" dot matrix printers (including those from Victor, LRC, Practical Automation and Amperex) with speeds up to 200 CPS! Operating from a single +5V power supply, the flexible CY-480 will interface easily with any microcomputer or minicomputer system through standard 8-bit ports. The CY-480 accepts either serial (RS232C) or parallel ASCII input from the host system's data channel.

The CY-480 replaces bulky, expensive, dedicated controllers.

This small, single LSI package offers a 5 x 7 dot matrix character generator, full upper and lower case ASCII 96-character font, and a 48-character (expandable by daisy-chaining) internal line buffer storage. Standard features include a 10, 12 or 16 characters/inch variable character density command, and horizontal and vertical independently expanded print command. The CY-480 provides graphics capability and includes a "flip-print" operating mode for 180° viewing, and ready lines provide full asynchronous communications with handshaking.

Stock delivery ... only \$35.00 a single unit ... send for YOURS today!

CYBERNETIC MICRO SYSTEMS
2378-B Walsh Ave., Santa Clara, CA 95050
Phone (408) 249-9255.

VISA and
MASTER CHARGE accepted.

FREE Catalog

New 4-way relief from problems with minicomputer supplies and accessories.

1. One-stop shopping.

Inmac (formerly known as Minicomputer Accessories Corporation) has a catalog of over 1000 products. Everything from racks and line-printer paper to connectors and cables. Each designed to help keep your minicomputer or word processing system up and running.

2. Hassle-free ordering.

Inmac lets you order by mail or phone. So keep our new Fall '79 catalog close. It makes those once-tough tasks like ordering magnetic media easy, fast and foolproof.

3. Fast shipment of just the quantity you need.

Inmac ships your order within 36 hours from centers in California and New Jersey. In a bind? Call us for many special services that insure you get your order to your installation within 24 hours. Call now and give us a chance.

4. Field-proven quality means precision performance.

Inmac guarantees every product in these 70 pages for at least 45 days. And even some for up to ten years.

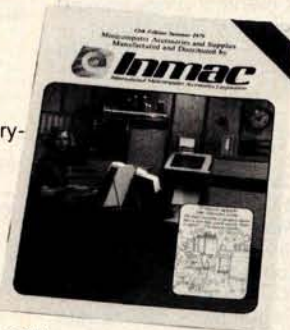

Inmac Send for your **FREE**
International Minicomputer Accessories Corporation
Inmac catalog or call
(408) 727-1970 today!

2465 Augustine Drive, P.O. Box 4780, Santa Clara, CA 95051
© 1979 International Minicomputer Accessories Corporation

North Star* and PASCAL Users:

Mike's
announces

Hard disk and 8" drive interfaces to North Star DOS and BASIC and PASCAL

TIMESHARING for the Horizon—

Interrupt-driven, bank switching timesharing software; supports North Star DOS and BASIC and PASCAL.

A complete selection of business application software is available for North Star* systems.

Write or call for descriptive literature.

Micro Mike's, Incorporated
905 South Buchanan * Amarillo, Texas 79101 * USA
(806) 372-3633

NO FRILLS! NO GIMMICKS! JUST GREAT DISCOUNTS MAIL ORDER ONLY

HAZELTINE		DIGITAL SYSTEMS	
1400	\$679.00	Computer	\$4345.00
1500	995.00	Double Density	
Mod 1	1495.00	Dual Drive	2433.00
CENTRONICS		IMSAI	
779-1	954.00	VDP 80/1000	\$5895.00
779-2	995.00	VDP 44	4195.00
700-2	1350.00	16K Memory assem.	399.00
761 KSR tractor	1595.00	PCS 80/15	679.00
703 tractor	2195.00	15% off on all other Imsai products	
Micro Printer	395.00	DEC	
NORTHSTAR		LA 34	
Horizon I assembled	1629.00	1149.00	
kit	1339.00	CROMEMCO	
Horizon II assembled	1999.00	System III \$1000 off ..	
kit	1599.00	4990.00	
Disk System	589.00	10% off on all other Cromemco products	
TELETYPE		TEXAS INSTRUMENTS	
Mod 43	995.00	810 Printer	
		1595.00	

Most items in stock for immediate delivery. Factory-fresh, sealed cartons.

DATA DISCOUNT CENTER P.O. Box 100
135-53 Northern Blvd., Flushing, New York 11354, 212/465-6609

N.Y.S. residents add appropriate Sales Tax. Shipping FOB N.Y.
BankAmericard, Master Charge add 3%. COD orders require 25% deposit.

information on LISP-like languages.

1. Quest Electronics
2. 2322 Walsh Ave, Santa Clara CA 95051
5. Questdata
6. William Haslacher
7. (408) 988-1640
8. \$12 per year
9. Monthly newsletter for 1802 microprocessor users.

1. HEX Users Group
2. 36012 Military Rd S, Auburn WA 98002
3. None
4. None
5. Irregular, 3 to 4 issues per year.
6. Charles C Worstell
7. (206) 927-6038
8. \$4
9. Devoted to systems without American Standard Code for Information Interchange (ASCII) keyboard (mostly 6800 D2)

1. 80-Northwest Publishing Co
2. POB 7112, Tacoma WA 98407

5. The 80-US Journal (bi-monthly)
6. Mike Schmidt, Editor
7. (206) 759-9642
8. \$16 per year (US)
9. The Journal is devoted entirely to the TRS-80 microcomputer system. It covers all aspects including business, scientific, educational, tutorials, hardware and

- games.
10. In less than 1 year, the Journal has gone international. It also pioneered the use of animated graphics with sound on the TRS-80. It gave birth to ANDY (Android Nim) and others, and introduced advanced "string packing" techniques.

Foreign Clubs and Newsletters

1. MICOM (The Microcomputer Club of Melbourne)
2. MICOM, POB 60, Canterbury, Victoria 3126 AUSTRALIA
3. AMRA Hall, Wills St, Glen Iris
4. Third Saturday of the month.
5. Newsletter (monthly); magazine (quarterly).
6. Andrew Stewart, Secretary
7. (03) 277-1613
8. \$7.50 per year
9. None; we try to interest all microcomputer enthusiasts.
10. Membership: 120-plus.

1. Australian 9900 Users Group
2. GPO Box 835, Melbourne, Victoria 3001 AUSTRALIA
3. None - correspondence only
5. None - direct contact
6. Barry Day
7. (03) 661-2523
8. None
9. Anything and everything to do with the 9900 or associated devices.
10. We are by necessity a correspondence group and are now in touch with groups in the USA and the United Kingdom.

We will always answer all correspondence promptly and would be glad to make new contacts in both hardware and software fields.

1. COM-3
2. POB 268, Niddrie, Victoria 3042 AUSTRALIA
5. COM-3
6. Timothy Mowchanuk, Editor
7. Work (03) 336-1855 Home (03) 379-6812
8. \$10 (in Australia), \$15 (Foreign - surface mail), \$25 (Foreign - airmail). All checks in Australian dollars. Make check payable to: C.E.G.V.
9. Educational uses of computers.

1. Brazilian Microcomputer Club, and TRS-80 Users Group
2. Attention: Douglas Gilson, Rua Sambaiba, No. 516, Leblon, Rio de Janeiro BRAZIL
3. Same as above
4. Weekly
5. None
6. Douglas Gilson

68 MICRO JOURNAL TM ★

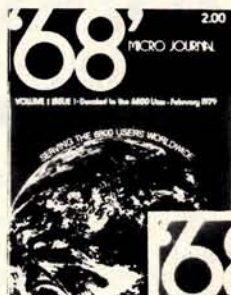

Months ahead of all others with 6800/09 articles & new products

Crunchers Corner — Bryant (A monthly programming tutorial) • Flex™ to BFD — Puckett • Tiny Music — Thompson • Semiconductor, Part 1 — Kinzer • Soup Up Your TVT — Pass • Hints & Kinks — fixes (soft & hard) • 50 pages plus Each Month!

Crunchers Corner — Bryant • A Look at the SWTPC CT-82 — Ferguson • 6800 Relative Branch Calculation (Hand) — Berenbon • Relative Calculator (Machine) — Heatherington • Maillist (Disk) — Lilly • Modems — Schuman • Semiconductor - Part 2 — Kinzer • Locate — Pigford • A20 MA, Printer-SWTPC — Perdue • AS-50 Monitor Board — Pentecost • TSC Basic for 6800 — Shirk • Plus Much-Much More!

Crunchers Corner — Bryant • A Case for the Small DOS — Mauch • MF-68 Motor Fix — Sorrels • Transfer (FLEX 1 to 2 or 5) — Womack • 6800 Delay — Berenbon • Make Like a 6809 — Feintuch • Games (Basic) — Harmon • Boot (Flex-BFD) — Puckett • Freeze Display (SSB) — Johnson • Paper Tape Reader — Adams • FLEX™ Fixes and Much More!

MAGAZINE COMPARISON (2 years) Monthly Averages 6800 Articles

KB	BYTE	CC	DOBB'S	TOTAL PAGES
7.8	6.4	2.7	2.2	19.1 ea. mo.

Average cost for all four each month: \$5.88
(Based on advertised 1-year subscription price)

'68 cost per month: \$1.21

That's Right! Much, Much More for About 1/5 the Cost!

EFFECTIVE SEPT. 1, 1979

1-Year \$14.50 2 Years \$26.00 3 Years \$36.50

OK, PLEASE ENTER MY SUBSCRIPTION

Bill My: Master Charge — VISA

Card # _____ Exp. Date _____

For 1-Year 2 Years 3 Years

Enclosed: \$ _____

Name _____

Street _____

City _____ State _____ Zip _____

My Computer Is: _____

68 MICRO JOURNAL
3018 Hamill Road
HIXSON, TN 37343

FOREIGN ADD:
\$9.50 Per Yr. Surface
\$29.00 Per Yr. Air Mail

★
★
**THE ONLY
6800/09
USER-ORIENTED
MAGAZINE**

★ MORE 6800 ARTICLES THAN ALL OTHERS COMBINED ★



**YOU'VE READ THEM ALL-
NOW GET THE BEST!**

The 80-US Journal

**A PUBLICATION FOR TRS-80
USERS - COVERS ALL TRS-80
CAPABILITY!**

*BI-MONTHLY, SEND \$16.00 CHECK OR
MONEY ORDER FOR A 1 YEAR
SUBSCRIPTION TO:*

**80 US
PO Box 7112
TACOMA, WA. 98407**

MASTER CHARGE, VISA OK - (206) 475-2219
WANT TO CHECK IT OUT FIRST? SEND \$3.00
for current sample copy.

A SELECT CHOICE OF SOFTWARE IS AVAILABLE

**ED SMITH'S SOFTWARE WORKS
NEW
6809 SOFTWARE TOOLS**

CROSSMAC A 6800 TO 6809 CROSS ASSEMBLER version of RRMAC which runs on your 6800 to produce relocatable 6809 object code from existing (6800) or new (6809) source files. Handles deleted 6800 instructions via macros. Supplied with 6809 machine language linking loader.

M68CX \$200.00

RRMAC RELOCATABLE RECURSIVE MACROASSEMBLER and LINKING LOADER for 6809. The one macro assembler with real macro capabilities. Retains all features of 6800 version.

M69RR \$150.00

M6809 RELOCATABLE DISASSEMBLER AND SEGMENTED SOURCE TEXT GENERATOR. An invaluable tool for modifying large object programs for reassembly on your system.

M69RS \$50.00

M6809 RELOCATING ASSEMBLER and LINKING LOADER is a version of RRMAC without its macro capabilities. Retains all of RRMAC's programmer convenience features.

M69AS \$75.00

All programs come complete with Programmer's Guide and extensively commented assembly listing. Available on cassette or mini-floppy. Specify cassette, SSB disk, mini-Flex disk or FLEX 2.0 disk.

Order directly by check or MC/Visa. California residents add 6% sales tax. Customers outside of U.S. or Canada add \$5 for air postage & handling.

Dealer inquiries welcome. FLEX is a trademark of TSC

Ed Smith's SOFTWARE WORKS
P.O. Box 339, Redondo Beach, CA 90277, (213) 373-3350

**FINALLY!
SECURITY FOR
CP/M FILES!
With LOCKER[©] and
CSPOOL[©]**

LOCKER[©]
Rewrites disk files in scrambled format with a 64 character "lock code". Added parity for Self-Correcting!

CSPOOL[©]
Transfers CP/M files to/from cassette tape!

Mail to: **INFINITY MICRO
P.O. BOX 4627
SANTA CLARA, CA 95050
(408) 988-1867**

- LOCKER @ \$38
- CSPOOL for Sorcerer @ \$38
- CSPOOL for Sol/CUTS @ \$38

Please specify disk as CP/M on 8" IBM standard or 5 1/4" Micropolis.

NAME _____
ADDRESS _____
CITY _____ STATE _____ ZIP _____

Copyright © 1979 Infinity Micro.

**the ULTIMATE in
CHEAP VIDEO**

**BOOK & KIT
ONLY \$42.95**

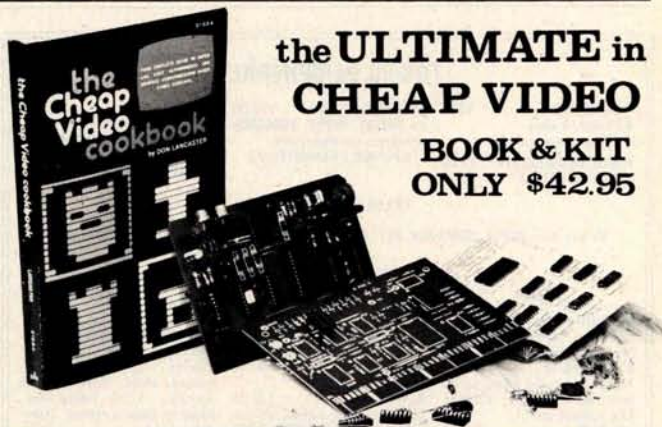

Don Lancaster's "Cheap Video" concept allows almost unlimited options, including:

- * Scrolling - Full performance cursor.
- * Line/Character formats of 16/32, 24/80, 32/64.... or almost anything.
- * Graphics - up to 256 X 256 B&W; 96 X 128 COLOR (requires low-cost option modules)
- * Works with 6502, 6800 and other micros.

SPECIAL OFFER: Buy the Kit (upper case alphanumeric option included) & get the Book at 1/2 price.

RIA ELECTRONICS, DEPT.10-B, 1020 W. WILSHIRE BLVD., OKLAHOMA CITY, OK 73116

I'm Sold. PLEASE RUSH..... () SEND FREE CATALOG
() TVT-6 5/g Kit & Cheap Video Cookbook - \$42.95 (enclosed)
() TVT-6 5/g Kit only (book required for assembly) - \$39.95
name: _____
address: _____
city: _____ state: _____ zip: _____

RIA ELECTRONICS DEPT.10 - B, 1020 W. WILSHIRE BLVD., OKLAHOMA CITY, OK 73116

Belais' Master Index to Computer Programs in BASIC Gives You Access to \$14,836.14 Worth of Computer Programs for Just \$7.95!

Now Available Off-The-Shelf

You paid hundreds or even thousands of dollars for your new microcomputer. By now it may be dawning on you that a \$1,000 computer with no software is just \$1,000 worth of scrap metal!

But computer programs cost money. In a recent survey of 1,984 computer programs offered for sale in the top three home computer magazines, the average price was found to be \$27.94. What a rip-off!

You don't need to spend hundreds of dollars to get a complete library of programs for your computer. That is, you don't if you have *Belais' Master Index to Computer Programs in BASIC*.

Belais' Master Index gives reviews of 531 programs that have appeared in 10 major home computer magazines—programs that you can type into your computer for free!

This large 8 1/2 x 11, 192-page directory is packed with information. This is not just a simple listing of article titles, but a complete reference work!

Each BMI review is complete—it has everything you need to know about a program. A brief index line capsulizes the review for quick reference. Source information shows you where the program can be found. Any updates or corrections are shown so you know the program is accurate and complete. The text of the review gives you a full description of what the program does. In addition, the review gives detailed technical information about what hardware and software the program needs. Everything you need to know is right at your fingertips!

We don't provide the program listings themselves, of course. But we do tell you where you can pick them up—even ones that appeared in print years ago.

You don't have to be a programming wizard to use *Belais' Master Index*. That's because BMI lists only finished, ready-to-run programs in BASIC, the easy-to-use language enjoyed by millions.

Even if you're a master programmer, you'll appreciate *Belais' Master Index*. Why slave away hours, days, or even weeks writing a program

when someone else has probably already done the work for you? These programs are working, documented, and ready-to-go.

Programs like: *Circuit Design, Psychoanalysis, PASCAL Compiler, Forrester's World Simulation, and Color T.V. Tester*. Never again will you have trouble answering that question: "But what are home computers good for?"

Then again, there's always MONEY. Maybe you haven't thought of all the ways your "fun" computer could turn out a little of the green stuff for you. Maybe you haven't—but a lot of other people have, and they've written up their ideas for you to use. *Belais' Master Index* lists dozens of programs that you can use to set up your own business.

If you already have a business, *Belais' Master Index* has the programs to turn your home computer into a full-fledged business system. General ledger, billing, payroll, mailing lists, word processing—no matter what type of business you have, *Belais' Master Index* has the programs you need.

All this and save \$2.00, too! The cover price of *Belais' Master Index to Computer Programs in BASIC* is \$9.95. But because you're buying by mail, we don't have to pay a commission to a bookstore. So we're going to pass the savings along to you. Order now and you can get your copy of *Belais' Master Index* for just \$7.95!

To order, write your name, address, and the words "Belais' Master Index" on a piece of paper. Make out your check for \$7.95 plus \$1 shipping (Calif. residents add 54c sales tax).

If you want to use your VISA or Master Charge card, give the total for your order, your account number, the expiration date of your card, and your signature.

Send your order to Falcon Publishing, Dept. X, 140 Riverside Ave., P.O. Box 688, Ben Lomond, CA 95005.

We absolutely guarantee you'll find *Belais' Master Index* one of the most useful books on your shelf. If you're not completely satisfied, return it to us within 30 days and we'll refund every cent you paid. You can't lose, so order NOW!

7. 274-0308, 274-2439
8. None
9. We receive manufacturer's news, software publisher's news, exchange programs, and exchange ideas.
10. Most of our club's members have the TRS-80, but we are open to anyone who has a microcomputer.

1. **The Ottawa Computer Group**
2. POB 13218, Kanata, Ontario, CANADA K2K-1X4
3. National Research Council, Sussex Dr, Ottawa
4. General meeting second Monday of each month
5. OCG Newsletter
6. Don Sharkey, President
7. (613) 824-0909, (613) 992-6858
8. \$10 (Canadian) for first full year \$5 (Canadian) for renewals
9. Active local user groups for most popular systems and processors. We have a locally designed and produced central processor board and expansion boards - The Mimic System. There also is an active Mimic users group.

10. Currently we are cooperating with the National Museum of Science and Technology in establishing a computer display. Weekly seminars or discussions are held for specific areas such as hardware, software and technical topics. Membership is approaching 250, monthly meetings are attended by an average of 110 members and guests.

1. **Association of Computer Experimentors (ACE)**
2. 102 McCrany St, Oakville, Ontario, CANADA L6H 1H6
3. Hamilton, Ontario
4. Monthly (September to May)
5. *IPSO FACTO*
6. Bernie Murphy
8. \$15 per year in Canada; \$18 per year elsewhere
9. Microcomputers based on the 1802 microprocessor. Our members have

various types of machines (ELF, VIP, Tektron, etc), and are involved in both hardware and software experimentation.

1. **Toronto Region Association of Computer Enthusiasts**
2. POB 6922, Postal Station A, Toronto, Ontario CANADA M5W 1X6
3. Ontario Science Centre and Humber College
4. Meetings are every second Sunday of month at 2 PM in the Ontario Science Centre and every fourth Friday at 7:30 PM at Humber College
5. *TRACE*
6. Ross Cooling
7. (416) 488-3314
8. \$13

1. **Vancouver PET Users Group**
2. POB 35353 Station E, Vancouver, BC CANADA
3. 404 East 51st Ave (Sunset Community Center)
5. *Vancouver PET News*
6. Niels Hansen-Trip
7. (604) 274-2064
8. \$20 per year including newsletter. Nonmember newsletter is \$1 per issue.
9. Support for the Commodore PET 2001 computer and every other conceivable computer device.
10. Meetings consist of presentations, demonstrations, and program swaps.

1. **Kitchener - Waterloo Microcomputer Club**
2. E2-3354 - Reading Room, Electrical Engineering Dept, University of Waterloo, Waterloo, Ontario CANADA N2L 3G1
3. Room 3388 Building Eng 4 University of Waterloo
4. First Wednesday of the month
5. None
6. Roger Sanderson
7. Home 885-2122, Work 885-1211 Ext 3815
8. None
9. All areas of microcomputing, especially hardware.
1. **North London Hobby Computer Club**

TRS-80 PERIPHERALS

DISK DRIVES \$320	16k MEMORY KITS \$70.00	PRINTERS from \$379
40 tracks, 2 sides with power supply & case	for TRS-80, APPLE, SORCERER w/jumpers and instructions	CENTRONICS, INTREGAL DATA, NEC SPINWRITER, TEXAS INSTRUMENTS, ALL AT GREAT SAVINGS!!
VERBATIM DISKETTES \$3.00	LIFETIME GUARANTEE!!!!	
DYSAN DISKETTES \$4.60		

TRS-80 computers in stock!!

We also carry **APPLE, SORCERER, PET, SD SALES** products. **WE WILL NOT BE UNDERSOLD.**

TRS-80 SOFTWARE

GAMES	UTILITIES	BUSINESS
ANDROID NIM \$14.00 nim robots that wink and respond. Excellent graphics and sound.	NEWDOS+ \$99.00 Enhanced DOS. Contains many improvements over TRSDOS. 7 useful utilities built in. For 40 track use also.	GL, AR, AP, INTERACTIVE \$350 reports include unbilled invoices, open/closed accounts, aging, Trial balance, income statement, balance sheet. Handles 200 accounts, 1750 transactions. Based on Osborne method. Stand alone of each \$125
STAR TREK III \$14.00 Travel through the galaxy on the Enterprise and destroy Klingons. New updated version.	NEWDOS \$49.00 Same as above without utilities.	INVENTORY II \$99.00 activity listing, complete listing, selected listing, minimum quantity search, 1000 items per disk
AIR RAID \$14.00 Real time shooting gallery.	SYSTEM INTEGRATION TEST \$29.00 tests memory, disk drives, and printer.	ALL ABOVE PROGRAMS BY SBSG
SARGON:CHESS \$19.00 Best chess for TRS-80	MICROSOFT FORTRAN \$325.00	ELECTRIC PENCIL \$99.00 by Michael Shrayner
LIBRARY 100 \$49.00 100 games, utilities, and business programs in one package. Great value!	CPM \$150.00	BEST word processor for the TRS-80 \$150.00
	RENUMBER \$14.00 disk	
	G2 LEVEL III \$49.00	
	FOURTH by MSS \$35.00	

The above list is just a brief summary of some of our most popular software. We have a large selection of other software for many uses and for many computers. Documentation for any of our programs is available on request. If you have any questions, please call. We would like to hear from you.

TO ORDER, CALL OR WRITE:

MIDWEST COMPUTER PERIPHERALS

1467 S. MICHIGAN AV.
CHICAGO, IL. 60605
(312) 251-5028



C.O.D.

*TRS-80 is a Registered Trademark of Tandy Corp.

FALL SPECIAL
10% Discount on all Software orders over \$100

STARFLEET ORION



A specially designed SF TACTICAL BATTLE GAME for your PET, TRS-80 or APPLE Computer.

The man called Sudden Smith watched the five blips on his screen spread out to meet the enemy. Two freighters converted into something like battlewagons, powerful but slow, and three real cruisers: the most powerful group of warships ever seen near the Promethean system — except for the Stellar Union fleet opposing them. Everyone was calling it Starfleet Orion, though it existed for only this day. It was life or death, and, after the object lesson on the planet Spring, everyone knew it.

STARFLEET ORION is a complete 2 player game system

- rule book
- battle manual
- cassette
- ship control sheets
- program listings

Includes 2 programs, 22 space ship types, and 12 playtested scenarios. Game mechanics are extremely simple, but play is exciting, challenging, and rich in detail. Specify PET (8K), TRS-80 (Level II, 16K), or APPLE II (16K & 32K) \$19.95.

Ask your local dealer or send your check to:

Automated Simulations
 Department Y
 P.O. Box 4232
 Mountain View, CA. 94040

California residents please add 6% sales tax

25 START-AT-HOME COMPUTER BUSINESSES

In "Low Capital, Startup Computer Businesses"

CONSULTING • PROGRAMMING • MICRO COMPUTER OPPORTUNITIES • SOFTWARE PACKAGES • FREELANCE WRITING • SEMINARS • TAPE/DISC CLEANING • FIELD SERVICE • SYSTEMS HOUSES • LEASING • SUPPLIES • PUBLISHING • HARDWARE DISTRIBUTORS • SALES AGENCIES • USED COMPUTERS • FINDER'S FEES • SCRAP COMPONENTS • AND MORE . . .

Plus — ideas on moonlighting, going full-time, image building, revenue building, bidding, contracts, marketing, professionalism, and more. No career tool like it. Order now — if not completely satisfied, return within 30 days for full immediate refund.

• 8½ x 11 ringbound • 156 pp. • \$20.00

Phone Orders 901-761-9090

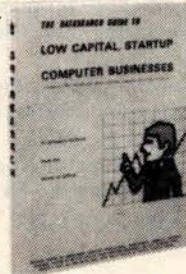

DATASEARCH

incorporated

4954 William Arnold Road, Dept. B, Memphis, TN 38117

Rush my copy of "Low Capital Startup Computer Businesses" at \$20.

NAME/COMPANY _____

ADDRESS _____

CITY/STATE/ZIP _____

Check Enclosed VISA Master Charge

_____ Exp. Date _____

TERMINALS FROM TRANSNET

PURCHASE FULL OWNERSHIP AND LEASE PLANS

DESCRIPTION	PURCHASE PRICE	PER MONTH		
		12 MOS.	24 MOS.	36 MOS.
LA36 DECwriter II	\$1,595	\$ 152	\$ 83	\$ 56
LA34 DECwriter IV	1,295	124	67	45
LA120 DECwriter III, KSR	2,295	219	120	80
LA180 DECprinter I, RO	2,095	200	109	74
VT100 CRT DECscope	1,895	181	99	66
VT132 CRT DECscope	2,295	220	119	80
DT80-1 CRT Terminal	1,795	172	93	63
T1745 Portable Terminal	1,875	179	98	66
T1765 Bubble Memory Term.	2,795	267	145	98
T1810 RO Printer	1,895	181	99	66
T1820 KSR Printer	2,395	229	125	84
ADM3A CRT Terminal	875	84	46	31
QUME Letter Quality KSR	3,195	306	166	112
QUME Letter Quality RO	2,795	268	145	98
HAZELTINE 1410 CRT	895	86	47	32
HAZELTINE 1500 CRT	1,195	115	62	42
HAZELTINE 1552 CRT	1,495	143	78	52
DataProducts 2230	7,900	755	410	277
DATAMATE Mini Floppy	1,750	167	91	61

FULL OWNERSHIP AFTER 12 OR 24 MONTHS
 10% PURCHASE OPTION AFTER 36 MONTHS

ACCESSORIES AND PERIPHERAL EQUIPMENT

ACOUSTIC COUPLERS • MODEMS • THERMAL PAPER RIBBONS • INTERFACE MODULES • FLOPPY DISK UNITS

PROMPT DELIVERY • EFFICIENT SERVICE



TRANSNET CORPORATION
 2005 ROUTE 22, UNION, N.J. 07083
 201-688-7800

CATCH THE S-100 INC. BUS!



	LIST PRICE	OUR SPECIAL CASH PRICE
Imsai "8080" Kit complete w/ Front Panel	750.00	625.00
S-100's Three Ring Binder w/Ten Vinyl Jackets for 5¼ Mini Floppies (Holds Twenty Diskettes Plus Directory Pocket)	13.00	7.00
Shugart SA400 5¼" Disk Drive	450.00	295.00
Intertec's "Intertube"	995.00	779.00
Thinker Toys 8" Add On Drive	795.00	675.00
Imsai MPU-A Kit	190.00	95.00

We carry all major lines such as S.D. Systems, Cromemco, SSM, Vector Graphic, North Star, Sanyo, ECT, TEI, Godbout, Thinker Toys, Hazeltine, IMC

For a special cash price telephone us.

Subject to Available Quantities • Prices Quoted Include Cash Discounts Shipping & Insurance Extra

Bus... **S-100, inc.**
 Address... **7 White Place**
Clark, N.J. 07066
 Interface... **201-382-1318**

2. c/o D.E.C.E. Polytechnic of North London, Holloway Rd, London N78DB ENGLAND
3. Polytechnic
5. *Gigo* (bimonthly)
6. Robin Bradbeer
7. 01-607-2789
8. £10 (1978/9)
9. Homebrew workshop; PET users group; games workshop; business users workshop; and Nascom workshop.
10. Regular courses on programming, digital electronics etc run by Polytechnic of North London for the NLHCC. £5 per course per member.

1. **Japan Microcomputer Club**
2. Kikashinko-kaikan, JEIDA 5-5-8, Shiba-koen, Minato-ku, Tokyo JAPAN
3. Tokyo
5. *Microcomputer Magazine* (monthly), *Microcomputer Circular* (monthly), *Microcomputer News* (English version, unperiodically), *Microcomputer Handbook* (annually)
6. Koji Yada
7. 0424-61-2141
8. Y3000 subscription, Y6000 dues, Y4800 for students
9. Microcomputer contest (twice a year); microcomputer seminar (20-30 times a year); and a Sunday school.
10. The main language is Japanese. We have about 2500 members in our 7 branches in Japan.

1. **Microtel-Club**
2. 9 rue Huysmans, 75006, Paris FRANCE 0 544 70 23
5. Yes
8. \$35 per year
9. The club's aim is to develop the interest of the French population in the microcomputer and telecommunications areas. We strive to give our members the opportunity to use and compare microcomputers. We support the most interesting projects of the club's users and promote exchanges among them.

1. **Microcomputer Club**
2. fte de Quijote #5, MEXICO 10, D.F.
6. Alfredo Buzali
7. 5-89-22-79 between 7 and 8 PM
9. Primarily concerned with the Apple II and Ohio Scientific products.

1. **Hobby Computer Club**
2. Christinastraat 171, 5 615 RK Eindhoven, NETHERLANDS
3. At 12 places throughout Belgium and the Netherlands.
4. Meetings are held at least monthly depending on the organizer.
5. *Hobby Computer Club Nieuwsbrief* (Dutch)
6. Erik Visser, Secretary
7. Netherlands 040-514017
8. 15 guilders for 1979, will increase for 1980 (225 Belgian franc)
9. No special favor for any computer or microprocessor. The main goal of the HCC is

- to increase contacts between computer amateurs, to exchange ideas and experiences.
10. Our A5-sized bimonthly *Nieuwsbrief* will be a full-sized monthly in 1980. Once a year we organize the HCC Day with a complete exhibition and a program of readings. Our yearly members list shows which computer is used and each member's applications. The HCC now has over 2300 members in Belgium and the Netherlands.

1. **Singapore Microcomputer Society**
2. 43K, Ponggol Rd, Singapore, 19, REPUBLIC OF SINGAPORE
6. Jack Page
7. 4680944
8. \$25 per year
9. To develop and encourage by all appropriate means the wider understanding and general use of microcomputers and related systems in new and productive applications.
1. **Transvaal Amateur Computer Club**
2. POB 6639, Johannesburg, SOUTH AFRICA
3. University of the Witwatersrand, Johannesburg
4. First Wednesday of every month, excluding January
5. Newsletter published monthly
6. Angus Anderson, Peter Hers
7. 784-3532 and 793-1576, respectively

8. R10-00 per year, no entrance fee
9. All aspects of small computers.
10. TAC² was formed in July 1977. Paid membership is now 210. Club members have developed and built their own machine, based on Motorola 6800 processor with their own 42-pin bus.
1. **Central Program Exchange (CPE)**
2. Department of Computing and Mathematical Sciences, The Polytechnic, Wulfruna St, Wolverhampton WVI 1LY UNITED KINGDOM
5. *Program Exchange*
6. Dr G Beech, Project Director
7. 0902 27371 Ext 159
8. Annual subscription United Kingdom and Europe £25. Overseas £40
9. New category of membership to encourage schools and other small users. Small user subscription is £10 per year and £20 overseas. CPE has published a booklet of computer programs suitable for use in schools: *Computer Resources for Education and Training - Schools Education* price £3.50 per copy.
10. Our library contains about 300 programs in various subject areas. ■

Cmc

PET ANALOG INPUT

DAM SYSTEMS

Analog to Digital Conversion System for the Commodore PET Computer

Give the PET the ability to sense, measure, and control the world around it with DAM SYSTEMS modules. Just plug the PETSET1 into the PET to set 16 channels of analog input. Screw terminals are provided for each channel so you can hook up joysticks, pots, or whatever appropriate sensors you have.

Each of the 16 analog inputs, in the range of 0 to 5.12 volts, is converted to a decimal number between 0 and 255 (20 millivolts per count). Conversion time is 100 microseconds.

In addition, the PETMOD provides two IEEE ports and one user port as well as a DAM SYSTEMS port.

Software is provided. A one line program is all that is necessary to read a channel.

PETSET1

- 1- AIM161 - 16 ANALOG INPUTS-8 BITS-100 MICROSEC
- 1- PETMOD - PET ADAPTER-2 IEEE PORTS - 1 USER PORT-1 DAM SYSTEMS PORT
- 1- CABLE A24 - 24 INCH INTERCONNECT CABLE
- 1- MANMOD1 - MANIFOLD MODULE - SCREW TERMINALS FOR INPUTS, REFERENCE, GROUND
- 1- POW1 - POWER MODULE

PETSET1a for 110 VAC \$295
 PETSET1e for 230 VAC \$305
 Order direct or contact your local computer store.

CONNECTICUT microCOMPUTER, Inc.
 150 POCONO ROAD
 BROOKFIELD, CONNECTICUT 06804
 TEL: (203) 775-9659 TWX: 710-456-0052

VISA AND M/C ACCEPTED - SEND ACCOUNT NUMBER, EXPIRATION DATE AND SIGN ORDER.
 ADD \$3 PER ORDER FOR SHIPPING & HANDLING - FOREIGN ORDERS ADD 10% FOR AIR POSTAGE.



MAIL ADDRESS
P.O. BOX 2528
ORANGE, CA 92669

STORE
2231 WEST BALL ROAD
ANAHEIM, CA 92804

* NORTH STAR * RADIO SHACK * APPLE II *

NEED BUSINESS SOFTWARE FOR YOUR NORTH STAR OR TRS-80 TRY OUR INTEGRATED BUSINESS SYSTEM FOR ONLY \$250.00. YOU GET ALL OF THE FOLLOWING SYSTEMS COMBINED INTO ONE NEAT PACKAGE:



- Accounts Receivable
- Accounts Payable
- General Ledger
- Payroll
- Inventory & Sales Analysis
- Business Statistics
- Letter Writer

DO YOU NEED A HEAVY DUTY WORD PROCESSOR WRITTEN IN BASIC FOR EITHER YOUR NORTH STAR OR TRS-80? EMULATES THE EDIT FEATURES OF THE COMPUTER YOU ARE RUNNING IT ON. FULL LINE-BY-LINE OR CHARACTER-BY-CHARACTER EDITING. YOU CAN REPEAT, RELOCATE OR ALTER TEXT WITH EASE, TAB CONTROL, RIGHT OR LEFT JUSTIFICATION, CENTERING AND MANY MORE OPTIONS. OUR PRICE FOR THIS GREAT SYSTEM IS ONLY \$99.00.

TRS-80 USERS TRY OUR NEW SECRETARIAL PACKAGE: WORD PROCESSING - PERIODICAL INDEX - CALENDAR GENERATOR WITH A BUILT IN APPOINTMENT REMINDER - A SIGN AND BANNER GENERATOR. ALL THIS FOR \$150.00.

APPLE II USERS TRY OUR NEW ACCOUNTS RECEIVABLE PACK FOR ONLY \$50.00. OR TRY OUR NEW STUDENT TESTING SYSTEM FOR ONLY \$35.00. THE STUDENT TESTING SYSTEM MAKES TAKING NOTES FUN. SEND FOR OUR CATALOG WITH OVER 100 SYSTEMS FOR ANY ONE OF YOUR PERSONAL OR BUSINESS NEEDS.

IF IN ANAHEIM, CA., SEE OUR NEW STORE AT 2231 WEST BALL ROAD. PHONE ORDERS O.K. B of A AND MASTERCARD ACCEPTED. WE MAY ALSO BE ABLE TO SATISFY YOUR CUSTOM PROGRAMMING NEEDS, GIVE US A CALL.

JUST DROP IN AT OUR STORE the 23rd Century or ORDER BY PHONE.

AJA AJA SOFTWARE
P.O. Box 2528 • Orange, CA 92669
(714) 774-1270



Main/Frames from \$200

Main/Frames from \$200

- 14 Basic Models Available
- Assembled & Tested
- Power Supply:
8v@15A, ± 16v@3A
- 15 Slot Motherboard
(connectors optional)
- Card cage & guides
- Fan, line cord, fuse, power
& reset switches, EMI filter
- 8v@30A, ± 16v@10A
option on some models



Rack mounted from \$200

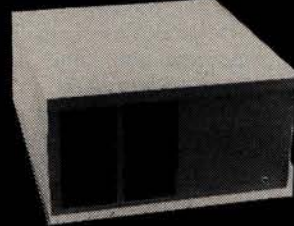

8" Floppy Main/Frame (includes power for drives and mainframe) from \$365

Write or call for our brochure which includes our application note:

'Building Cheap Computers'

INTEGRAND

8474 Ave. 296 • Visalia, CA 93277 • (209) 733-9288
We accept BankAmericard/Visa and MasterCard



BASEX MEANS SPEED!

BASEX is a fast, easy to learn language for 8080, Z80, or 8085 microcomputers. Its commands resemble BASIC, making translation easy. An interactive compiler permits

you to enter, list, edit and run programs up to 10x faster than similar BASIC programs and use half the memory (2K plus program).

Powerful features include:

- * Array variables
- * 16 Bit Arithmetic/Logic
- * Variable name length
- * Named subroutines with multiple arguments
- * Text strings
- * Versatile I/O Functions
- * Block memory searches/transfers
- * Custom commands easily added

CHOOSE YOUR BASEX . . .

- * 97-Page BASEX manual (pub. by Byte Books) \$ 8
- * North Star Disk/Meca Alpha Tape/Paper Tape \$25
- * TRS-80 Level II, 16K tape with graphics commands \$25
- * CPM 8" Disk, with disk handler commands \$35
- * Basex Tape & Disk Guide-provides complete handlers for North Star Disk and/or Meca Tape (includes manual with source) \$35
- * Add \$.75 shipping (special 4th class) or \$1.50 special handling on all orders.

See BASEX at your local dealer or order direct from



Interactive Microware, Inc.
P.O. Box 771
State College, Pa 16801
(814) 238-8294

DEALER INQUIRIES INVITED

At last . . . the mechanical interface

Turn your electric typewriter into a low cost, high quality hard copy printer.

30 Day Delivery

User list \$439⁰⁰

Dealer Inquiries Invited.



Now available with interfaces for most personal computers: TRS-80, Apple, GPIB, etc.

The all new I/O Pak from Rochester Data, Inc. interfaces the keyboard of any commercially available electric typewriter with any computer. The result: low cost, high quality hard copy. Write today for more information.

ROCHESTER DATA
Incorporated

3100 Monroe Avenue, Rochester, New York 14618

**Practical Microcomputer
Programming:
The Intel 8080**

by W J Weller,
A V Shatzel, and H Y Nice
Northern Technology Books
POB 62, Evanston, IL 1976
306 pages hardcover
6½ by 9¼ inches
\$23.95

**Practical Microcomputer
Programming:
The M6800**

by W J Weller
Northern Technology Books
POB 62, Evanston, IL 1977
288 pages hardcover,
6½ by 9¼ inches
\$23.95

**Practical Microcomputer
Programming: The Z80**

by W J Weller
Northern Technology Books
POB 62, Evanston, IL 1978
481 pages hardcover,
6½ by 9¼ inches
\$32.95

Book Reviews

Practical Microcomputer Programming is a series of books begun in 1976 and masterminded by Walter Weller. Mr Weller is an applications software consultant specializing in the industrial, medical, and educational uses of small computers, and is the founder of Northern Technology Books, the publishers of this series.

It is quite obvious that Mr Weller has a natural feel for how to present such technical material. Each book is presented in lucid, readable terminology, and the layout is carefully designed to treat each topic separately and completely. This gives the reader not only a tutorial workbook to learn more about the art of assembly language programming, but also an excellent

reference text which will be used time and again in preparing new projects.

The objective of the series is to directly address the difficulties of microcomputer application programming in assembly language as simply as possible. Although many programmers see little need to get embroiled in the complexities of an assembly language when a higher level language such as BASIC is available, there are indeed many applications in which a program in assembly language is desirable. In some applications it is absolutely necessary. Two important considerations in choosing to use an assembly language are necessary memory restrictions and speed.

First, recall that this series was begun in 1976. At that time most programmers doing work on microcomputers did not have the amount of memory thought of as common today. Presently programmers think nothing of talking about 64 K byte systems, and while such a large amount of memory is still not cheap, nonetheless it is within the realm of affordability, or at least will be in the very near future. In 1976, however, it was rare to think in terms of more than 4 K bytes of memory; consequently, getting a program to execute with the least amount of memory was paramount. A high-level language was a luxury few could afford. Therefore, in 1976 minimum memory requirements were quite important. But what about now, when a 64 K byte chip is within the foreseeable future?

Obviously there are still many times when a minimum amount of memory should be used. There are many industrial applications which still require strict conservation of available memory. Today there is

hardly a major home appliance or piece of office equipment that does not have a microprocessor controlling it, and it certainly is not cost effective to provide each of these machines with the 16 or 32 K bytes of memory necessary to support programming them in a high-level language. But there is one other consideration for using assembly language: speed.

Speed is one of the major reasons that assembly language programming retains strong adherents. Assembly language programming is necessary to handle various tasks such as interfacing software, input and output handlers, and real-time controllers, because the electronics involved keeps getting faster. Assembly language programming is often a must for the transfer of data between any of several devices at a rate consistent with the speeds at which these devices operate.

There is another good reason for wanting to learn assembly language programming. There isn't an exact term to describe it, but words like fun, self-filling, and fascinating partially describe the feeling one has after mastering assembly language programming. It lets you into that mystical world of the system programmer, it allows you to become intimate with the most inner workings of your computer, it lets you feel in total control of the sometimes awesome power the computer engenders. All in all, the individual becomes a more effective, confident, and efficient programmer.

What has all this to do with this series of books? It is Walter Weller's contention that learning to program in an assembly language should be a painless, rewarding



DATA PRIVACY FOR TRS-80 !

FEATURES: KEY LENGTH=80 bits (more than DES!)
DATA RATE: Exceeds 15,000 chars./sec.
Pocket-size encryption device
Plugs into TRS-80 ready to use

introductory
price: \$299

IS YOUR DATA SECURE ?

Write for brochure & price list.



CRYPTTEXT
CORPORATION

P. O. Box 425
Northgate Sta.
Seattle, WA 98125

(206) 364-8585

experience. There is nothing inherently intimidating about assembly languages, yet they have acquired a reputation guaranteed to frighten the novice programmer. It was apparently Mr Weller's goal from the beginning to present the fundamental concepts of assembly language programming in a completely non-threatening way. He has accomplished this goal better than any other author to date.

Each book of this series is a completely self-contained guide to the assembly language of a particular microprocessor. Each is packed with examples of assembly language routines which perform real functions useful to the novice programmer. These routines not only supply the reader with instant software for a variety of applications, but also abundantly illustrate the usefulness of assembly language programming. I found each book of the series to be logically designed, including chapters detailing one particular area of assembly language programs, appendices with source listings of significant software, and a comprehensive index making it easier to use the books as reference texts.

These books are *not* exhaustive discussions of the programming characteristics of a particular microprocessor, nor do they represent complete details on all possible assembly language programming techniques. What these books do represent is a suitable cross-section of techniques that will aid the novice assembly language programmer in sharpening skills, while serving as an excellent reference resource for the experienced programmer. As for the particular microprocessor each book covers, the discussion is specific and to the point, not theoretical or general.

One final comment on the series as a whole before discussing particular details of each book: every line of code printed in each book

has been checked and rechecked, right up to the moment before the book is actually printed. This helps eliminate annoying typesetting errors in the listings. While this does not absolutely guarantee the correctness of the examples or programs listed, it certainly goes much further in doing so than most publishers care to pursue. This represents a tremendous plus to the reader.

The Intel 8080 is the first book of the series, published in 1976. Although the 8080 is one of the older microprocessors on the market, there are several manufacturers (including Heath Company and Compucolor Corp) still basing their systems on this chip. In other words, this book still applies to a large number of machines currently available.

There are over 80 example programs used to illustrate the solutions to common problems facing the assembly language applications programmer. These examples are practical as well as explanatory and can often be used directly to form parts of applications programs.

The authors cover a lot of territory in the 18 chapters, 3 appendices, and index of this book. They naturally begin with binary arithmetic and logical (AND, OR, NOT) operations, bringing the programmer familiar with high-level languages, but not assembly language "down" to the proper level of thinking. Next, a definition of what constitutes memory and how it is accessed in a microcomputer is covered, which gives the novice assembly language programmer a basic idea of where things are located inside the machine.

After the preliminaries are out of the way, the authors describe the parts of an assembly language program, such as labels and operands. Also discussed are assemblers, cross-assemblers, and loaders.

Chapter 4 begins the detailed descriptions of 8080

instructions, including moving data, binary arithmetic, software multiplication and division, and using the stack pointer. Chapter 8 then employs what has been learned so far to construct a number of commonly required subroutines.

Next, binary-to-decimal and decimal-to-binary conversions are covered, allowing the programmer to format input and output, which is the subject of the next chapters: communicating with a terminal, and controlling a printer. Other types of communication to the physical world, such as digital and analog output, are also discussed.

Chapters 16 and 17 cover a topic usually omitted from a programming guide, interrupt-driven processes. First, the concept of a real-time clock and its uses are discussed, then the necessary considerations of real-time input and output are detailed. While the novice programmer may not be able to use the information in these

2 chapters immediately, the authors clearly show that progressing to that level is not that difficult, and the added flexibility of being able to take real-time events into account is of great benefit to the assembly language programmer.

The final chapter discusses many helpful ways to debug assembly language programs, the bane of many a programmer. Techniques here are illustrated using the authors' own debugging program, a tool serious programmers can not afford to be without. It allows inspection and modification of memory, single-step execution via breakpoints, and many other handy techniques. The authors have included the source code of this program in the book, which is a real bonus.

In addition to the debug program listing in the appendices, the authors have also included the source listings of the cross-assembler and loader used on the Computer Automa-

MAGSAM™

KEYED FILE MANAGEMENT SYSTEM

Sophisticated applications made simple.

Put data at your fingertips...easily accessed, displayed, and updated by key. MAGSAM™ allows your CBASIC programs to create and access sophisticated keyed file structures through simple CBASIC statements.

Powerful, affordable, and easy to use.

MAGSAM™ is now available in three versions offering an array of features and capabilities. Standard MAGSAM™ features include random by key, sequential by key, generic by key, randomly by record number, and physical sequential access techniques. Each MAGSAM™ Package includes the MAGSAM™ file manager, tutorial program, file dump utility, User Guide, Reference Card, and one year update service.

- **MAGSAM™** — Most advanced version. Secondary Indexing with any number of keys, and Record and Key Deletion with automatic reuse of freed space. \$145†
- **MAGSAM II™** — Single Key support with full Record and Key Delete capability. \$99†
- **MAGSAM I™** — Entry level version. Single Key support without Delete functions. \$75†
- **MAGSAM™ User Guide only** — comprehensive tutorial and reference manual. \$15

Available for 8" soft sector, Micropolis, and TRS-80 disk formats. Requires CP/M™ or derivative and CBASIC. Distributed as CBASIC subroutines in source form.

Visa and MasterCard welcome. Dealer and OEM inquiries invited.



MICRO APPLICATIONS GROUP

7300 CALDUS AVENUE
VAN NUYS, CA 91406

* Trademark of Digital Research. † Single site license

tion LSI/2 to produce object code for the 8080. This assembler will assemble all hardware instructions detailed in Intel's document #98-004C Rev C, 8080 *Assembly Language Programming Manual*, plus "certain compound and pseudo instructions." What this means is that, throughout the text, the authors have chosen to use different mnemonics for certain instructions, "for clarity." An example is ReSet Carry (RSC) instead of ORA A. The authors' intentions are certainly appreciated, but it is unclear whether or not this offers an advantage to the programmer just learning 8080 assembly code, especially if he or she has access to an assembler which uses Intel mnemonics. Certainly it is easier to remember that RSC means reset carry (as opposed to ORA A), but is it realistic to assume that the reader will be in a position to take advantage of the improvement?

Only a few of the dozens of mnemonics were "improved," so hand translation is not difficult. The authors have been careful to identify which ones were changed, and the comprehensive index makes locating references in the text simple.

Once author Weller had

put together a winning combination of information, he knew not to tamper with success. The M6800 and Z80 books have essentially the same information that the 8080 book does, but naturally there are specific differences for these microprocessors. There are a few differences in the conclusions, such as chapters on floating point arithmetic in the M6800 and Z80 books, and graphic output in the Z80 book, but by and large, each book covers the same general territory. In essence, then, Weller has written the same book 3 times. This certainly has its advantages, because now it is easy to compare the performance and instruction characteristics of these 3 microprocessors.

In the M6800 book, Weller again provided a listing for a debugging program as part of the appendices. As in the 8080 book, a number of the instruction mnemonics as defined by Motorola were found not suitable, and so Weller made a few substitutions of his own mnemonics (for example, DATA instead of FCB). As long as the reader is aware that this is happening (which the author points out in the preface), he or she will not have any trouble following the discussions.

Weller's Z80 book turned out to be a more ambitious project, however. It includes a complete description and source code listing of an assembler of Weller's own design, in addition to the by now anticipated debugging monitor. These programs are available in paper tape or TRS-80 cassette form from the publisher, free of charge with the return of the coupon from the book.

In the Z80 book, Weller also chose to go his own way with the assembly language mnemonics, even more so than with the M6800 and 8080 instruction sets. Essentially, he felt that Zilog did a great disservice to 8080 owners by completely redefining the mnemonics of their chip, even though a great part of the instruction set is exactly the same as that of the 8080. In actuality, the Z80 instruction set is an extended 8080 instruction set, except that Zilog used a different set of mnemonics for the instructions the Z80 has in common with the 8080.

All this means is that those who are experienced in 8080 assembly language are forced to learn an entirely new set of mnemonics for the Z80, even though the actual execution of the instructions would be exactly the same as before. Weller perceived this as an

injustice to 8080 users; that being the case, his assembler merely extends the 8080 instruction set to include the full use of Z80 instructions. This approach will obviously alienate some Z80 users, but no doubt will please those upgrading from an 8080 based system to a Z80. The author also provides a complete table which translates the mnemonics he uses in his assembler and debugger to the Zilog mnemonics. I prefer not to take sides in this matter, but I can't help but admire Weller for taking a stand for simplicity.

Practical Microcomputer Programming is a very powerful series. It is well written and full of essential techniques for the assembly language programmer. The final question is: "what is next for Walter Weller?" The author intends to continue the format used for the Z80 book and provide a complete assembler for the 6502. He is hard at work on this assembler, and hopes to publish the book around the beginning of 1980. At long last 6502 users will have a definitive resource for this much neglected microprocessor. I am sure that the book will be well worth the wait. ■

Blaise W Liffick
Senior Book Editor
Byte Publications

Our 1st Anniversary Computer Sale

The CBM™ 16K \$995
Cassette Recorder free

Expand to 32K for an additional \$149
Dual floppy disk drive 2040 w/cable \$1295
Single floppy disk drive \$895
Pin feed printer 2023 \$849
Tractor feed printer 2022 w/cable \$995
Inventory management software - requires 16K system w/dual floppy and printer \$125
Text editor software - requires 16K system w/ dual floppy and printer \$125

All sales cash. No COD's. 3½% service charge on CHECKS, VISA AND MASTERCARD.
Sale ends December 15, 1979. NO REFUNDS.
Add 2% for shipping and handling. California residents add 6% sales tax.
Allow 2 weeks for cashiers check to clear, 4 weeks for personal checks. Prices subject to change without notice.

 **apple II**

Apple II 16K \$1195
Buy an Applesoft Card for only \$35

Apple II Plus 16K \$1195

Buy an Integer Card for only \$35

16K Expansion Memory \$95*

PASCAL Language System \$459

15% OFF on all Apple software and interface boards. All merchandise is factory warranted.

*\$10.00 installation charge is required.

CCI of south bay

15818 Hawthorne Blvd.
Lawndale, CA 90260
(213) 370-4842

Pascal / MT

from

Meta Tech

8080 / Z80

- COMPILER & SYMBOLIC DEBUG!
- RUNS UNDER CP/M [& Derivatives]
- Generates Romable Machine Code
- Needs only 32K bytes
- Output is 10X faster than P-code
- Efficiently compiles a subset of Standard Pascal

Available for ALL CP/M Systems

\$99.95

Options include: real/business arithmetic multi tasking, interrupt procedures, etc.

Call/Write **Meta Tech**
3308 Midway Drive
Suite 289
San Diego, CA 92110
(714) 223-5566 X289

Dealer Inquiries Invited



BET, YOU DIDN'T KNOW!

OAE'S new **PP-2708/16** PROM Programmer is the *only* programmer with all these features:

- Converts a PROM memory socket to a table top programmer: No complex interfacing to wire—just plug it into a 2708 memory socket*
- A short subroutine sends data over the address lines to program the PROM
- Programs 2 PROMS for less than the cost of a personality module. (2708s and TMS 2716s)
- Connect 2 or more in parallel — super for production programming
- Complete with DC to DC switching inverter and 10

turn cermet trimmers (for precision pulse width and amplitude alignment)

- All packaged in a handsome aluminum case

PP-2708/16 . . . A & T \$325.

PP-2716 (Programs Intel's 2716) A & T \$295.

OAE

Oliver Advanced Engineering, Inc.
676 West Wilson Avenue
Glendale, Calif. 91203
(213) 240-0080

*Pat's Pending



A Message to our Subscribers

From time to time we make the BYTE subscriber list available to other companies who wish to send our subscribers promotional material about their products. We take great care to screen these companies, choosing only those who are reputable, and whose products, services, or information we feel would be of interest to you. Direct mail is an efficient medium for presenting the latest personal computer goods and services to our subscribers.

Many BYTE subscribers appreciate this controlled use of our mailing list, and look forward to finding information of interest to them in the mail. Used are our subscribers' names and addresses only (no other information we may have is ever given).

While we believe the distribution of this information is of benefit to our subscribers, we firmly respect the wishes of any subscriber who does not want to receive such promotional literature. Should you wish to restrict the use of your name, simply send your request to BYTE Publications Inc, Attn: Circulation Department, 70 Main St, Peterborough NH 03458. Thank you.

PET WORD PROCESSOR



This program permits composing and printing letters, flyers, advertisements, manuscripts, etc., using the COMMODORE PET and a printer. Script directives include line length, left margin, centering, and skip. Edit commands allow the user to insert lines, delete lines, move lines and paragraphs, change strings, save onto cassette, load from cassette, move up, move down, print and type. The CmC Word Processor Program addresses an RS-232 printer through a CmC printer adapter. The CmC Word Processor program is available for \$29.50. Add \$1.00 for postage and handling per order.

Order direct or contact your local computer store.



CONNECTICUT microCOMPUTER
150 POCONO ROAD
BROOKFIELD, CONNECTICUT 06804
(203) 775-9659
TLX: 7104560052



An ASCII String Program

William Comer, 419 Blackman St, Lake Charles LA 70605

Programming long American Standard Code for Information Interchange (ASCII) strings or a large number of strings can be a tedious job. The Motorola 6800 program in listing 1 simplifies the task by automatically setting up the proper hexadecimal codes in the ASCII string. This program assumes you are using a 6800 system with the Motorola MIKBUG monitor program. You simply type in the statements you want printed during execution of a machine language program. The starting address of the ASCII string is stored in hexadecimal locations A000 and A001 (high- and low-order byte respectively) before executing the program.

Using the Program

When a point is reached where you want to insert the text in your machine language program:

- Load the program starting at hexadecimal memory location 0100.
- Load the starting address of the ASCII string at hexadecimal address A000 and A001.
- Load the starting address of the program into hexadecimal memory locations A048 and A049 (01 in A048, 00 in A049).
- Start the program by typing G.
- Type in the statements exactly as you want them printed.
- Return to MIKBUG control by hitting the reset button.

Listing 1: M6800 program to load ASCII characters into memory using MIKBUG and MP-C Interface.

Address	Hexadecimal Code	Label	Op Code	Operand	Commentary
0100	CE 80 04	START	LDX	#PIAD	
0103	A6 00	IN1	LDAA	0,X	Look for start bit.
0105	2B FC		BM1	IN1	
0107	6F 02		CLR	2,X	Set counter for 1/2 bit.
0109	8D 28		BSR	DE	Start timer.
010B	8D 22		BSR	DEL	Delay 1/2 bit time.
010D	C6 04		LDAB	#4	Set delay full bit time.
010F	E7 02		STAB	2, X	
0111	58		ASLB		Set up counter with 8.
0112	8D 1B	IN3	BSR	DEL	Wait 1 character time.
0114	0D		SEC		Mark commentary line.
0115	69 00		ROL	0, X	Get bit into CFF.
0117	46		RORA		CFF to AR.
0118	5A		DECB		
0119	26 F7		BNE	IN3	
011B	8D 12		BSR	DEL	Wait for stop bit.
011D	84 7F		ANDA	#97F	Reset parity bit.
011F	81 7F		CMPA	#97F	
0121	27 E0		BEQ	IN1	If rubout, get next character.
0123	FE A0 00		LDX	ASSA	ASCII string start address.
0126	A7 00		STAA	0,X	
0128	08	INX			
0129	FF A0 00		STX	ASSA	
012C	7E 01 00		JMP	START	
012F	6D 02	DEL	TST	2, X	Is time up?
0131	2A FC		BPL	DEL	
0133	6C 02	DE	INC	2, X	Reset timer.
0135	6A 02		DEC	2, X	
0137	39		RTS		

Listing 2: To print an ASCII string during a machine language program, insert these 2 instructions into the program.

Hexadecimal Code	Op Code	Operand	Commentary
CE XX XX	LDX	# String	Memory location. XXXX is the starting address of the ASCII string.
BD E0 7E	JSR	PDATA 1	MIKBUG subroutine to print on ASCII string.

SORCERER* SOFTWARE!

FOUR PROGRAMS ON CASSETTES

FASTGAMMON™ by Bob Christiansen. Thousands of people are already playing FASTGAMMON on TRS-80 and Apple. Now it is ready for SORCERER, with the sharpest graphics ever! Backgammon players love this machine language program that provides a skillful opponent. Eight-page instruction manual includes rules of backgammon. **\$19.95**

PLOT by Vic Tolomei. Now Apple owners will be envious of how easy you can get good graphics on your SORCERER. PLOT includes both a super high resolution mode and a quick low resolution mode. Both are accessible from your BASIC programs using simple commands. Hi-res & lo-res examples included on tape. **\$14.95**

Z-80 DISASSEMBLER by Vic Tolomei. Decode machine language programs, including SORCERER'S monitor and ROM-PACs, with this Z-80 Disassembler written in BASIC. Instruction mode prints out machine code and Zilog mnemonics in standard format. Or use the ASCII mode which converts machine code to ASCII. **\$14.95**

MAGICMAZE™ by Vic Tolomei. A challenging maze game. Ten levels of play. Holding your lantern, you wander through a maze trying to stay on the right path and avoid pitfalls. Automatic scoring tells you how good a pathfinder you are. **\$11.95**

SOFTWARE INTERNALS MANUAL FOR THE SORCERER by Vic Tolomei. A must for anyone writing software for the SORCERER. Seven chapters: Intro to Machine Language, Devices & Ports, The Monitor, Cassette Interface, BASIC structure, Video & Graphics, The Keyboard. Indexed. Includes diagrams and software routines. 64 pages. **\$14.95**



QUALITY SOFTWARE

6660 Reseda Blvd., Suite 103, Reseda, CA. 91335
Telephone 24 hours, seven days a week: (213) 344-6599

WHERE TO GET IT: Ask your nearest Sorcerer dealer to see *Quality Software's* Sorcerer programs. Or, if you prefer, you may order directly from us. MasterCharge and Visa cardholders may telephone their orders and we will deduct \$1 from orders over \$19 to compensate for phone charges. Or mail your order to the address above. California residents add 6% sales tax. Orders outside North America add \$5 for registered airmail, pay in U.S. currency.

* The name "SORCERER" has been trademarked by Exidy, Inc.

BYTE BACK ISSUES FOR SALE

The following issues are available:

July, November, 1976; March, May thru December, 1977; February thru October, December 1978; and all of 1979.

Cover price for each issue thru August '77 is \$1.50 plus 25¢ postage and handling (\$3.50 total foreign).

September '77 thru '79 issues are \$2.00 plus 50¢ postage and handling (\$4.00 total foreign).

Send requests
with
payment
to:

BYTE
Publications
70 Main St.
Peterborough
NH
03458

Attn:
Back Issues

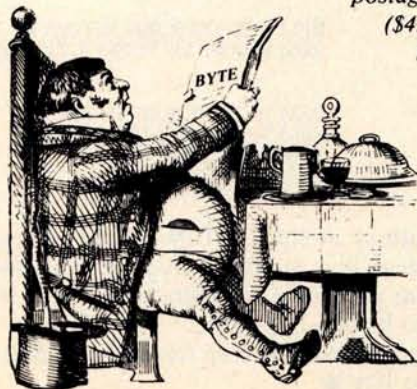

**SAVE!!
TRS-80**

**10, 15
Percent
and More!**

on ALL Computers, Peripherals, Software, and ALL other fine Radio Shack® products.

Radio Shack®

Authorized Sales Center

1117 CONWAY MISSION, TEXAS 78572

(512) 581-2765



NO TAXES on out-of-state shipments.
FREE Surface delivery available in the U.S.
WARRANTIES will be honored by your local
Radio Shack® store.

THE BRAND NEW EXCEL TX-80 DOT MATRIX PRINTER ONLY \$560⁰⁰

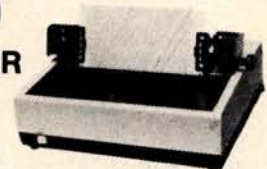

STANDARD FEATURES:

- 80 columns on plain paper with adjustable paper width
- 150 characters per second (70 lines per minute) throughput;
- Friction feed standard, tractor feed at \$25 more
- 96 character set (upper and lower case) plus PET*'s graphic set
- Elongated character (double width printing)
- Microprocessor control and self-test when power up
- Centronics compatible parallel interface
- 90 days warranty parts and labor

OPTIONAL INTERFACE BOARDS & CABLE SETS:

- PET*, APPLE II*, TRS-80* and serial interface board available at \$60 each
- All our interface boards reside inside the printer and does not require extra power supply
- Cable for each interface is available at extra cost

SEND ORDERS TO:

P. O. Box 1147
El Cerrito, Calif. 94530
Phone: (415) 465-4240

TERMS:

- Checks, Master Charge and Visa accepted • Allow up to 4 weeks for delivery
- Please add \$15 per printer for shipping & handling • Calif. residents add 6% sales tax.

EXCEL COMPANY

MICRO COMPUTER SYSTEMS
618 GRAND AVENUE
OAKLAND, CALIF. 94610

We are the original PET* Keyboard Interface people

*Trade Marks of Commodore, Apple & Tandy Corp.

Tremendous Savings on Refurbished AJ Couplers/Modems

Your chance to buy the best from the world leader in data communications. We have a variety of couplers and modems—formerly on lease to our customers—fully refurbished. This is a rare opportunity for you to have the same models used by the largest companies in the world.

- Some models under \$100!
- 30-day parts/labor warranty
- Nationwide AJ service network
- Fast delivery
- Variety of models—up to 1200 baud
- Limited quantities
- Use your Visa or Master Charge

Act now. First come, first served. Write Anderson Jacobson, Inc., 521 Charcot Ave., San Jose, CA 95131. Or call your nearest AJ office:

San Jose, CA Rosemont, IL Hackensack, NJ
 (408) 946-2900 (312) 671-7155 (201) 488-2525



MICRO-AMERICA has it in stock!!

• COMMODORE •

- 8K PET \$ 795
- 16K PET \$ 995
- 32K PET \$1295
- 2040 DISKS \$1295
- 2022 PRINTER (Tractor) \$ 995
- 2023 PRINTER (Friction) \$ 849⁹⁵



FAST, OFF THE SHELF DELIVERY ON:

- COMMODORE PETS & Peripherals
- TEXAS INSTRUMENTS 99/4 Personal Computer
- CENTRONICS Printers
- HP-41C
- Accessories

For Prices, Information or Phone Orders, Call:
(617) 879-8709

To Order by Mail, Send a Check or Money Order to:

MICRO-AMERICA
 P. O. Box 894
 Framingham, Mass. 01701

Circle 237 on inquiry card.

The address in memory locations A000 and A001 is the location following the last character in the ASCII string. Read this location and insert hexadecimal 04 into the memory location listed in hexadecimal A000 and A001. This will be used as an end of text marker by a MIKBUG routine (PDATA1).

To output the ASCII string during a machine language program, insert the program section shown in listing 2. This program saves a lot of time when programming a large number of long ASCII strings. It has saved me many hours of tedious programming. ■

Table of Subroutines

Peter W Meek, 1788 Miller Ave, Ann Arbor MI 48103

If you have a subroutine in a program, it is very likely you wrote the first line on a nice even number like 5000 or 10000. Now the program is finished, and it is time to neaten it up. You type the REnumber command, but where is your subroutine now?

If you put a table of subroutines at the end of every program, as shown below, the renumber command will keep track of them for you.

```

10      REM                START OF PROGRAM
...
...
4999   END                :   REM END OF PROGRAM
5000                                     REM START OF SUBROUTINE #1
...
...
5900   RETURN             :   REM END OF SUBROUTINE #1
10000                                     REM START OF SUBROUTINE #2
...
...
10900  RETURN             :   REM END OF SUBROUTINE #2
20000                                     REM TABLE OF SUBROUTINES
20010  GOTO 5000          :   REM SUBROUTINE #1
20020  GOTO 10000         :   REM SUBROUTINE #2
99999  END
```

Now the destinations of the GOTOs will be changed along with the actual line numbers. A program listing will end with a clear statement of where to look for that line which seems to have a bug in it.

Of course, this can be used to keep track of any part of a program that you like. ■

What's New?

MISCELLANEOUS



Sharp Introduces Alphanumeric Calculators

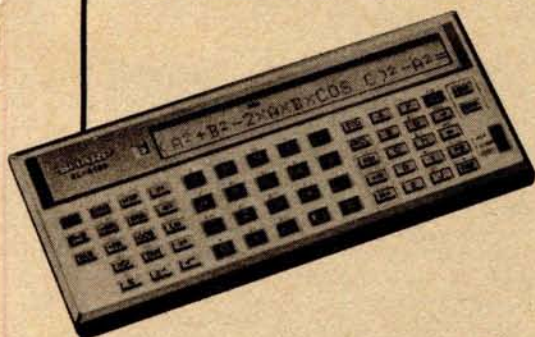

Sharp Electronics Corp has introduced two handheld scientific calculators in which alphanumeric formulae can be entered as written without being translated into machine language. The most complicated formulae can be entered into the machine and displayed, and can be visually edited, corrected, or tested without going through any translation phase. The key to the versatility of both machines is an exclusive "rolling writer" dot matrix liquid crystal display which shows numbers, letters

and symbols. Because the entries roll across the liquid crystal display, as many as 80 entries can be made.

The EL-5100 has a 24-character display which can enter and store up to 80 steps, because of the rolling writer feature. It has 61 keyed functions, 10 data memories, and Memory Safe Guard to maintain data and programs even when the power is off. The EL-5100 accepts the input of complicated formulae with up to 15 levels of parentheses and 8 levels of pending operations. Complex formulae can be stored as long as needed. Five formulae, with up to 80 steps, can be stored for easy calculations and recalled at the touch of a key. Ten variables can be stored and used in the formulae.

The EL-5101 has capabilities similar to the EL-5100. It has a 16-character display which can roll to 80 characters, storage up to 48 steps, and six data memories.

Both models are wafer-thin, horizontally held, weigh just over 5 ounces, and come in a brushed metal finish. The EL-5100 is priced at \$99.95 and the EL-5101 is \$79.95. For further information, contact Sharp Electronics Corp, 10 Keystone Pl, Paramus NJ 07652.

Circle 622 on inquiry card

Encryption Device Secures Data in TRS-80

CRYPTTEXT is a hardware encryption device designed to plug directly into the back of the Radio Shack TRS-80 Model I or into the expansion interface via an optional cable. The device allows users to secure virtually any data stored on cassette tapes or on disks against unauthorized access. Used with a modem, CRYPTTEXT allows data or messages to be transmitted by telephone or other communication channels in complete privacy. Other uses include generating pseudorandom numbers for games or scientific programs.

Prior to encoding data, CRYPTTEXT requires a user to enter a 10-character key; each of the 2^{80} possible keys results in a different and completely incoherent version of the data submitted for encryption. To decode secured data, four elements are essential: the encrypted data, the CRYPTTEXT unit, the software, and the correct user-supplied key. The lack of any of these elements prevents access to the original data.

The price is less than \$300 and includes demonstration software and user-oriented documentation. Optional cable and additional tape or disk software are available for a small additional charge. For further information, contact CRYPTTEXT Corp, POB 425 Northgate Sta, Seattle WA 98125.

Circle 623 on inquiry card

What's New?

MISCELLANEOUS

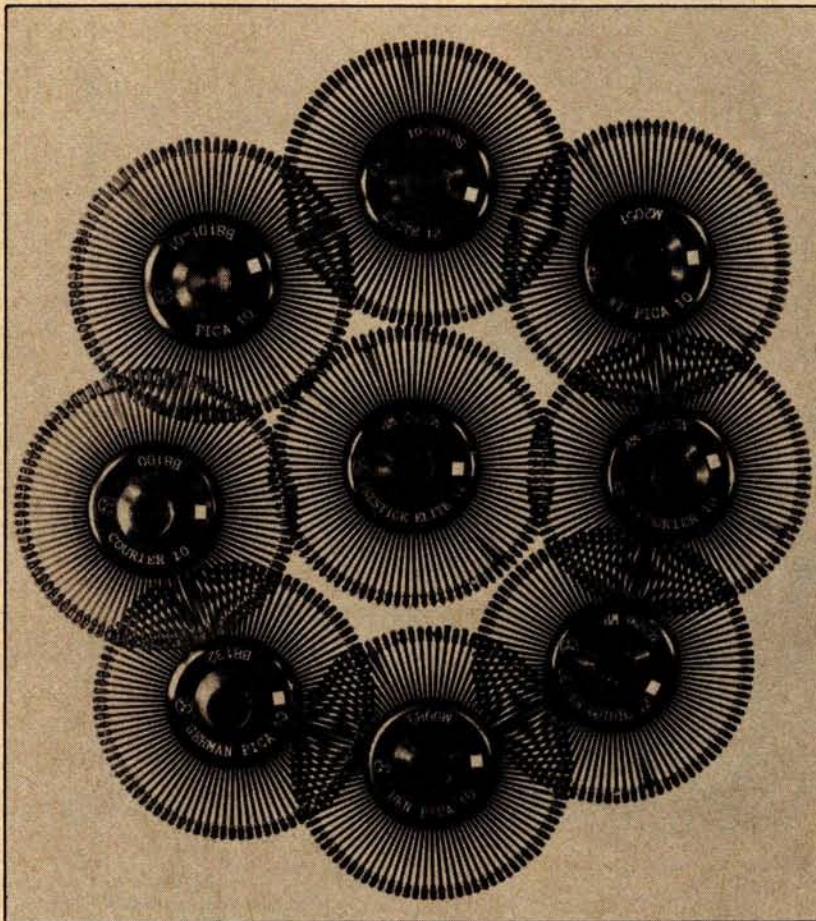

Daisy Printwheels

These plastic daisy printwheels with 96 character positions are available from AGT Computer Products Inc, 10906 Rochester Ave, Los Angeles CA 90024. They presently offer 27 Qume compatible and 13 Diablo compatible types, including those which are more commonly used. These printwheels have rubber buttons with a plastic disk on the top for ease of handling. All printwheels

have a metallized period, extra heavy underscore, and reinforced hub and spoke stress-points. In addition, 2 IBM compatible printwheels in Orator and OCR-B types with the flip-top clasp for use in the IBM 6240 system are available. The company manufactures special wheels to order, and will modify existing molds in order to accommodate special characters or logos.

Circle 586 on inquiry card.

Portable Computer System

Called the MAScot, this complete computer system is housed in a portable carrying case. The system contains the following modular components: a 5-inch, 7 by 9 dot matrix video displaying all 128 characters of the American Standard Code for Information Interchange (ASCII) set, single or dual 5-inch floppy disk drives offering 80 to 320 K bytes of data storage, 40 or 80 column dot matrix printer, 300 or 1200 bits per second (bps) modem with built-in acoustical coupler, and 8- or 16-bit microprocessor featuring up to 1 M bytes of programmable memory. The

carrying case also contains extra storage space, and the top cover is removable. The design highlights minimum size and weight combined with durability. MAScot firmware is extended BASIC, featuring integrated assembly instructions using a high-level incremental compiler. The operating system handles multidisk files.

Depending upon configuration, the price ranges from \$3999 to \$9999. For further information, contact Micro Application Systems Inc, 4345 Lyndale Ave N, Minneapolis MN 55412.

Circle 587 on inquiry card.

Microbench 8086 Software

A series of computer programs to support applications development for the Intel 8086 16-bit microprocessor, Microbench 8086, has been announced by Virtual Systems Inc, 1500 Newell Ave #406, Walnut Creek CA 94596. These programs operate in conjunction with PDP-11 and LSI-11 computers to provide an economical program development capability for the Intel 8086.

Included in Microbench 8086 software are a relocating assembler, linking loader, librarian, and object file formatter. The assembler supports extensive macro and conditional assembly capabilities, cross reference listings, and provides for memory addressing beyond 64 K bytes. The loader provides linkage facilities, selective loading from libraries, and directives for specifying read-only and programmable memory alignment boundaries.

The object file formatter produces binary modules in compatible formats for use with programmable read-only memory programmers and emulation systems. Microbench software is coded in Macro-11 for high throughput, and operates under RT-11, RSX-11M, RSX-11D and RSTS/E operating systems. Perpetual license fees start at \$1695 including documentation and first-year maintenance.

Circle 588 on inquiry card.

Where Do New Products Items Come From?

The information printed in the new products pages of BYTE is obtained from "new product" or "press release" copy sent by the promoters of new products. If in our judgement the information might be of interest to the personal computing experimenters and homebrewers who read BYTE, we print it in some form. We openly solicit releases and photos from manufacturers and suppliers to this marketplace. The information is printed more or less as a first in first out queue, subject to occasional priority modifications. While we would not knowingly print untrue or inaccurate data, or data from unreliable companies, our capacity to evaluate the products and companies appearing in the "What's New?" feature is necessarily limited. We therefore cannot be responsible for product quality or company performance.

What's New?

MISCELLANEOUS

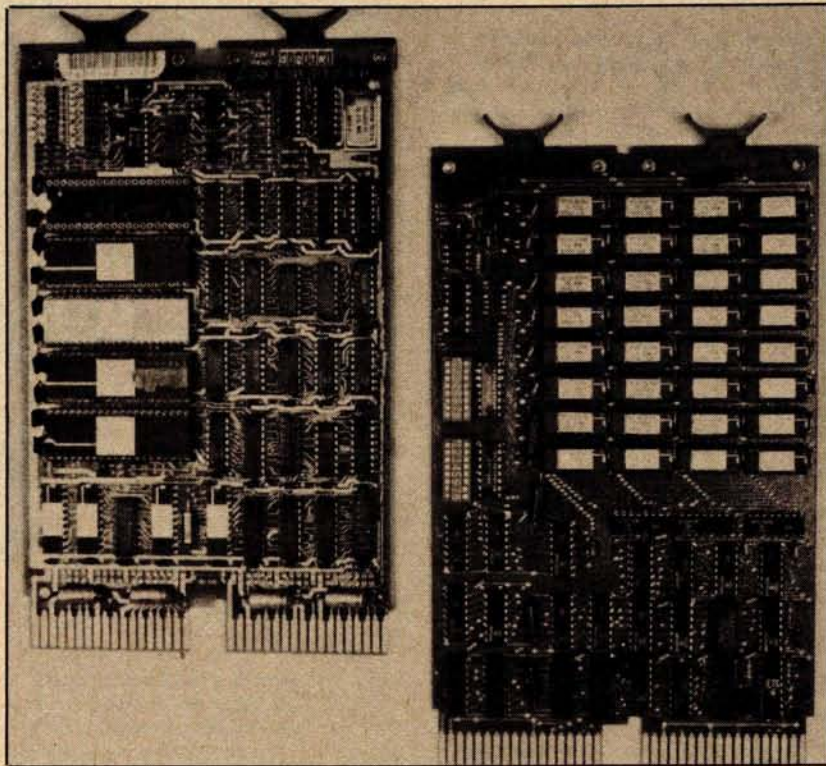

64 K Byte Microcomputer System

This 2 board microcomputer system utilizes DEC's LSI 11/2 central processing unit model KD11-HA with power fail and auto restart, 16-bit I/O (input/output) direct memory access (DMA) port, real-time clock input, vector interrupt handling, and Chrislin Industries' CI-1103 32 K byte by 16 memory board. The programmable

memory module has an access time of 300 ns from synchronous active and the cycle time is 525 ns. On-board memory select is available in 2 K byte increments up to 128 K words. Complete power consumption is under 6 W. The memory is tested and burned in and warranted for a full year. The single quantity price is \$1250. For further information, contact Chrislin Industries, 31312 Via Colinas #102, Westlake Village CA 91361.

Circle 592 on inquiry card.

Single-Board Microcomputer System Designed as Learning Aid

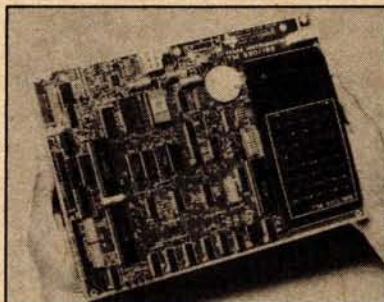

The TM990/189M, a self-contained

single-board microcomputer system, has been announced by Texas Instruments Inc. This microcomputer system is designed as a completely assembled learning aid for hands-on experience, plus instruction in microcomputer fundamentals, assembly and machine language, and microcomputer interfacing.

The board is self-contained with 1 K bytes of programmable memory (expandable on board to 2 K bytes) and 4 K bytes read-only memory (expandable on board to 6 K bytes). The read-only memory contains the system monitor (UNIBUG) and a symbolic assembler. Mass memory storage can be accomplished with the audio cassette interface. Built into the TM990/189M is a 45 key alphanumeric keyboard and a 10 digit, 7 segment display. The display has a 32 character buffer. It may be

Single Read-Only Memory and I/O Timer

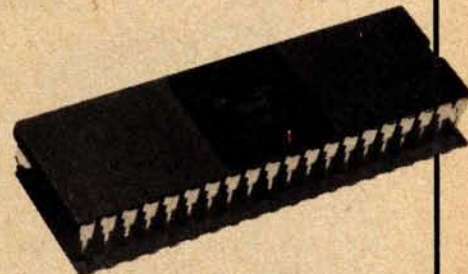

This read-only memory and I/O (input/output) timer can be used with the S6802 microprocessor to form a complete S6800 microcomputer with only 2 integrated circuits. The new device will also work with the S6800, S6801, S6808, S6809 or the 6500 family microprocessors.

Designated the S6846, the device combines 2 K bytes of read-only memory, an 8-bit bidirectional data port with 2 control lines for a parallel interface, a programmable interval timer and counter, and programmable registers for peripheral I/O data and control. The S6846 is the first part in the S6800 family to feature an automatic hardware power on reset capability.

The mask programmable device is fully compatible with transistor-transistor logic as well as with other members of the S6800 family. It operates from a single +5 V DC power supply. Read-only memory code for the device can be developed on the AMI MDC-100 Microcomputer Development Center using 6800 assembly language, though specific control software for the S6846 must be user developed.

Contained in a 40-pin dual-in-line package, the S6846 is priced at \$7 in plastic and \$8.95 in ceramic. For further information, contact American Microsystems Inc, 3800 Homestead Rd, Santa Clara CA 95051.

Circle 593 on inquiry card.

shifted right or left to view any 10 digits of the 32 character buffer. Provisions are on the board to add an external, standard EIA terminal or teletypewriter interface.

Other features of the TM990/189M include a series of addressable light-emitting diodes (LEDs). Coupled with these visual indicators is a piezoelectric speaker for audio signals.

The TM990/189M is priced at \$299 and the optional power supply (TM990/519) is \$65. For further information, contact Texas Instruments Inc, POB 1443 M/S 653, Houston TX 77001.

Circle 594 on inquiry card.

What's New?

MISCELLANEOUS

Microcomputer With Large Characters Ideal for Instruction



The EduCALC 189 GD is a 16-bit printed circuit board designed specifically for instruction. The instructor has an onboard 45-key alphanumeric keyboard and gets input, output and status information from the light-emitting diode display. Large characters on the other side of the unit repeat this display to the audience.

Assembly-language programming is featured with minicomputer instruction set; read-only memory resident software (including system monitor for program debug and symbolic assembler); single step execution; cassette interface; EIA and Teletype interface; 1 K byte programmable memory and 4 K byte read-only memory (expandable); 16-bit programmable I/O (input/output) controller and interrupt monitor; 2 MHz clock; also software and firmware compatibility with the entire TI 9900 family of microprocessors.

The price of the EduCALC 189 GD is \$1074 which includes TM 990/189 board and power supply, a 570-page tutorial text, a 300-page user's guide, and a rigid carrying case. There is a one-year warranty on the neon display and interface and a 90-day warranty on the TM 990/189. Contact Educational Calculator Devices Inc, POB 974, Dept 14B, Laguna Beach CA 92652.

Circle 611 on inquiry card.

Acoustically Coupled Modem

CAT is an acoustic modem which is designed to transmit data over all telephone lines. It allows one computer or terminal to talk to another. Data exchange can occur at any speed up to 30 characters per second (300 bps). The device offers features that include Bell 103 compatibility; answer, originate, and test modes with full and half duplex; and light-emitting diodes for displaying unit status. Standard on the modem are an acoustic self-test and a compact power supply that plugs directly into wall sockets to reduce heat and voltage hazards. For further information, contact Hamilton Avnet Electronics, 10950 Washington Blvd, POB 2647, Culver City CA 90230.

Circle 618 on inquiry card.

8085 Microcomputer Card

The SSM-85/2 is a general-purpose single-board applications control computer measuring 4.5 by 6.5 inches (11.43 by 16.51 cm). The card features a 4-level programmable interrupt; 256 bytes of programmable memory; 1 K bytes of erasable read-only memory (expandable to 2 K bytes); I/O (input/output) consists of 22 parallel lines with an additional 6-bit memory-mapped port; a serial EIA level I/O port; a programmable 14-bit binary counter and timer which is controlled by the system 3 MHz crystal and a software-readable switch. The processor has an instruction cycle time of 1.33 μ s and is software compatible with the 8080A.

The SSM-85/2 assembled circuit card is priced at \$197. For further information, contact System Service, 3627 Longview Valley Rd, Sherman Oaks CA 91423.

Circle 612 on inquiry card.

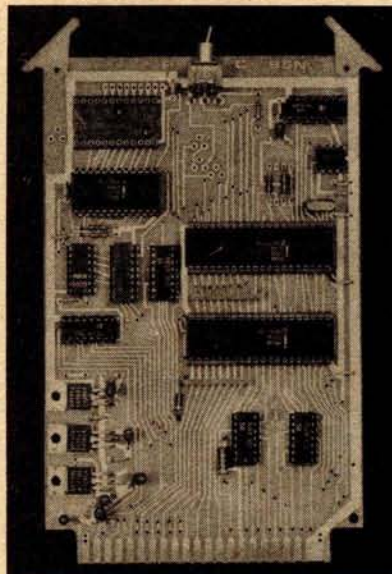

Manual Aids TRS-80 Users in Utilizing Level II BASIC Read-Only Memory

The *Software Technical Manual* has been written by the technicians at Houston Micro-Computer Technologies Inc to provide the assembly programmer with documentation of the TRS-80 Level II BASIC read-only memory entry points and provide working examples of

their use. The manual is for the person that understands and programs in Z80 assembly language and is interested in writing fast, computer-oriented programs. It is organized in sections which emphasize different aspects of computation. The *Software Technical Manual* sells for \$49.95. The address of the company is 5313 Bissonnet, Bellaire TX 77401.

Circle 613 on inquiry card.

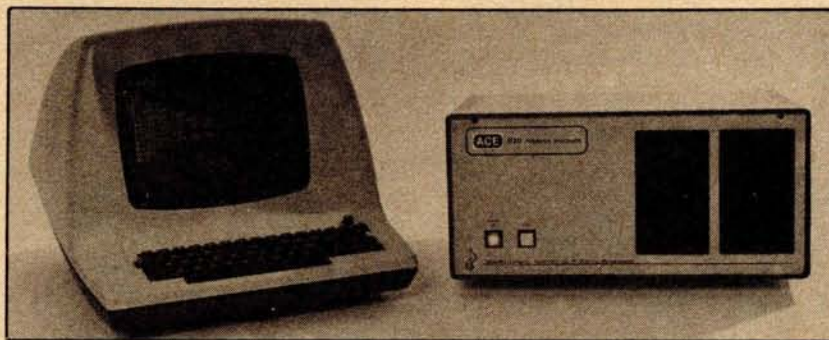

High-Quality S-100 Cabinet

Designated the Model 2150, this industrial-quality electronics cabinet is for hobbyists and system designers using the S-100 bus. The Model 2150 features a split construction design permitting rapid, easy access to all components by the removal of two screws. Heavy duty, 22-gauge steel is used throughout. A louvered bottom panel and louvered sides plus a fan facilitate air flow for efficient thermal characteristics. Com-

ponents are mounted on a separate, removable chassis enabling rapid troubleshooting. One or two 5-inch disk drives are mounted in electrically shielded enclosures protecting media from spurious noise. A fully shielded and terminated 8-slot backplane is totally compatible with the S-100 bus.

The Model 2150 electronics cabinet is priced at \$795. For further information, contact Advanced Computer Equipment Inc, 3 Republic Rd, N Billerica MA 01862.

Circle 619 on inquiry card.

What's New?

MISCELLANEOUS

Video Timer and Controller Device from Texas Instruments



This single device video timer and controller has been announced by Texas Instruments Inc, POB 1443 M/S 6404, Houston TX 77001. A silicon gate, N-channel metal-oxide semiconductor (MOS) device, the TMS9927, offered in a 40 pin dual-in-line package, generates video display timing signals for standard and nonstandard video monitors that incorporate both interlaced and non-interlaced formats.

The TMS9927 may be used with either 8- or 16-bit processors, including the TMS9900 family as a memory mapped I/O (input/output) device. It can also communicate with the communications register unit (CRU) interface of the TMS9900 family via the TMS9901 programmable systems interface.

Five sections comprise the new video timer and controller: processor interface, cursor control, horizontal control, vertical control, and self-load. The video timer and controller provides 9 user programmable control registers. Seven registers control horizontal and vertical formatting, and 2 control the cursor address.

The architecture of the TMS9927 is intended to allow maximum design flexibility. Most raster scan videos may be controlled by the TMS9927 by appropriately programming the control registers. The TMS9927 is interchangeable with Standard Microsystems Corporation's (SMC) CRT 5027.

Priced in 100 piece quantities, the TMS9927 video timer and controller is \$22.50 in plastic and \$27 in ceramic.

Circle 595 on inquiry card.

48 K Byte Dynamic Programmable Memory Board

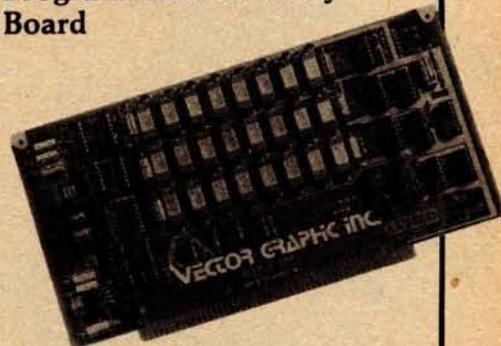

This 48 K byte dynamic programmable memory board featuring complete compatibility with Z80 based S-100 bus microcomputer systems has been introduced by Vector Graphics Inc, 31364 Via Colinas, Westlake Village CA 91361. The board incorporates the Z80 refresh mode for problem free, transparent refresh, and consumes less than 4 W of total power. Superior reliability is ensured because of a low parts count and low operating temperature. It is also tested with over 400 million error-free read and write cycles before being thermally cycled and aged. Fully assembled, the Vector Graphic 48 K byte dynamic programmable memory board is priced at \$695.

Circle 596 on inquiry card.

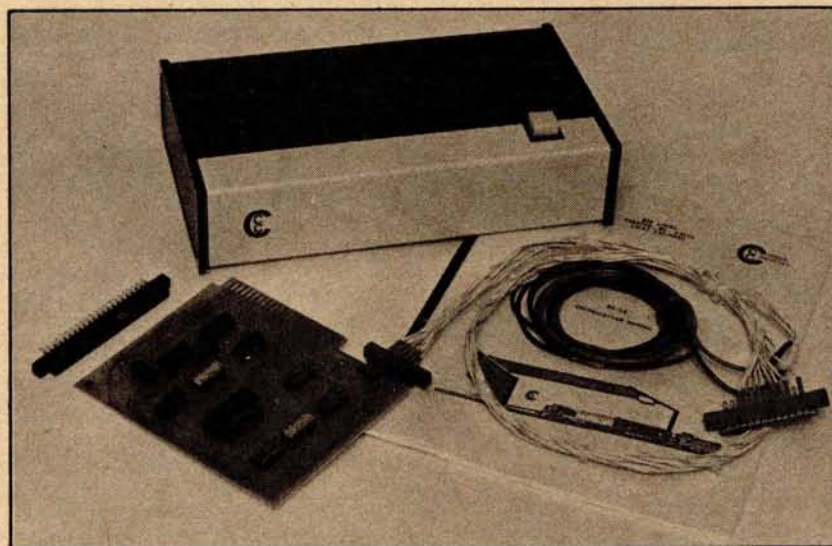

Control System for TRS-80 and PET Computers

Able to sense up to 24 inputs and drive 16 medium power outputs, the SY-16 is a plug compatible turnkey control system with all software and hardware furnished. The 16 output devices can be any 6 V or less on/off mechanism using less than ¼ A. Relay coils can be driven directly. By selecting a 6 V relay with appropriate contacts, AC signals and power can be switched,

controlling most equipment originally designed for manual operation.

Input devices can be transistor-transistor logic (TTL) gates, or any form of switch contacts, including thermostats, reed switches, microswitches, joysticks, keyswitches and numeric keypads. The SY-16 can sense open or closed conditions. Up to 8 switches can be wired for fast operation. A switch

closure can be captured and held, or noisy contacts can be debounced.

A software timing and control program (STAC) allows the user to specify and execute complex timing, sensing, and control sequences without having to program or write programs which call STAC as a subroutine. An interactive program is also furnished to help design sequences and experiment with them.

The SY-16 comes completely assembled, tested and ready to plug into TRS-80s (model T) or PETs (Model P) with software and comprehensive instruction manual describing sequence design, I/O (input/output) device control, STAC operation, and example applications for \$289. The instruction manual is available at \$12 and refundable upon SY-16 purchase within 60 days. For further information, contact Cooper Computing, POB 16082, Clayton MO 63105.

Circle 597 on inquiry card.

What's New?

SOFTWARE

Apple II Disassembler



Appletext is a powerful, new, 2-pass disassembler for the Apple II microcomputer. This programming tool disassembles any machine language program which resides in the Apple II. The disassembler creates a text file and assigns labels which enable the programmer to make them more useful. Initially, the label assignments contain the starting address of all subroutines. The disassembler will be valuable to any programmer who wants to rewrite, debug, modify, analyze, and understand the workings, functions and operation of inadequately documented programs for which there are no available source listings.

The disassembler is available on cassette with instructions for \$29.95. For further information, contact MicroProducts, 2107 Artesia Blvd, Redondo Beach CA 90278.

Circle 577 on inquiry card.

Cross-Assembler for 6800s

The 2-pass Macro Cross-Assembler from Hemenway Associates generates relocatable and linkable code. It requires the LNKEDT68 which is described below. Resident on a 6800 system, XA6809 lets the user immediately produce code for a 6809. It produces a listing, a sorted symbol table, a cross-reference list, and relocatable object code. This program features fast execution, full macro facility, relocation, and linking.

The LNKEDT68 system utility manipulates the relocatable file produced by the cross-assembler and Hemenway Associates' RA6800ML assembler and

Apple II Tiny Business Software

Tiny Business Inventory Management System, Accounts Receivable and Accounts Payable for the Apple II offer a realistic approach to the capabilities of the Apple II in a Tiny Business environment. Each software package requires a minimum system configuration of 48 K bytes and 1 disk drive and an optimum configuration of 2 disk drives and floating point firmware. The Inventory Management System supports 820 separate inventory items and quantities to assist the user in evaluating stock sales. The Accounts Payable and Accounts Receivable software handle 150 accounts each. All software packages have password protection to allow the user security on sensitive portions.

The Inventory Management System is priced at \$100, while the Accounts Payable and Accounts Receivable software is \$75 each. For further information, contact Custom Computing Systems Inc, 204 2nd Ave N, Saskatoon, Saskatchewan CANADA S7K 2B5.

Circle 578 on inquiry card.

All States Payroll System

A fully user defined, all states payroll system has been announced by Payne, Jackson, and Associates (PJA), 447 E Fifth Ave, Anchorage AK 99501. Simultaneous multistate processing of up to 4 states is also possible. All standard reports with current, month, quarter, and year to date amounts, plus a limited report generator are included. The system supports 3 and in some cases 4 levels of control to permit the maximum in flexibility within a given payroll. The standard controls are used for company-wide items, while the exception controls and override controls are used for specific employees. Small and simple payrolls are also easily handled.

The system runs on an Alpha Micro and is part of the PJA Accounting System which is currently available for \$500.

Circle 579 on inquiry card.

STRUBAL+ compiler as well, producing runnable binary files with the desired relocations and linkages performed. More sophisticated than a simple linking loader, LNKEDT68 is a 2-pass, disk-to-disk program. The user can build output files without regard for the amount of programmable memory available at load time.

Super BASIC for 6800 Computers Using PerCom 5-Inch Floppy Disk Systems

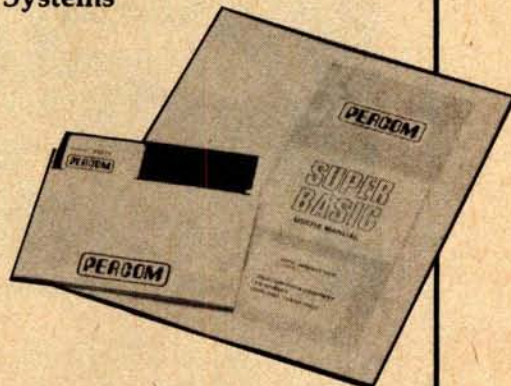

PerCom Data Company has announced Super BASIC for 6800 computers using PerCom's LFD-400 or LFD-1000 5-inch floppy disk systems. An extended disk BASIC, similar in dialect to Southwest Technical Products' (SwTPC) 8 K byte BASIC, Super BASIC supports 42 commands and 31 functions. The program requires 12 K bytes of memory. Super BASIC is compatible with programs written in SwTPC 8 K byte BASIC (versions 2.0, 2.2, and 2.3). Besides additional commands and functions, it includes refinements that reduce program run times by 35 to 40 percent. Other enhancements include direct random access to disk file data; optional use of the question mark in lieu of the Print command; 9 digit binary-coded decimal (BCD) arithmetic; named disk file and batch processing capability when Super BASIC is used with PerCom miniDOS; line and character position error reporting; and fast execution of function calls.

Super BASIC is supplied on 5-inch disks and, together with a users manual, sells for \$49.95. Upgrade kits for using Super BASIC with SwTPC or Smoke Signal Broadcasting Co disk systems are also available. For further information, contact PerCom Data Co, 318 Barnes, Garland TX 75042.

Circle 580 on inquiry card.

Versions are available for Percom, ICOM, SwTPC, Smoke Signal Broadcasting and Tano systems. The XA6809 is priced at \$149.95, and the LNKEDT68 is \$49.95. For further information, contact Hemenway Associates Inc, 101 Tremont St, Suite 208, Boston MA 02108.

Circle 581 on inquiry card.



HOBBY WORLD®

CALL TOLL FREE: (800)-423-5387

CA, HI, AK: (213) 886-9200

Your one-stop mail order computer store!



APPLE

COMPUTALKER SPEECH SYNTHESIZER

The finest low cost, high quality electronic speech synthesizer. Programmable to any language or dialect.

Cat No. 1916 For Apple II \$490

5 1/4"

VERBATIM DISKETTES

\$29
Cat No. 1148
box of 10

SSM AIO APPLE II SERIAL & PARALLEL INTERFACE

Interface your Apple with printers, plotters, terminals, modems, etc. Features one RS232 serial interface, two bi-directional 8-bit parallel ports, on board firmware. With comprehensive users manual and application notes for interfacing with many popular printers and terminals.

Cat No. 1918 kit \$129
Cat No. 1919 add \$169

APPLE TALKER

Give your Apple the power of speech! Digitizes words and sets up a table so that these words can be called on under program control. Requires recorder + 2 mikes. This and Apple Lis'n'r can be used as subtitles.

Cat No. 1691 \$15.95

APPLE LIS'NER

Communicate with your Apple via speech! Use your cassette recorder and a mike. Responds to words it has learned under program control.

Cat No. 1692 \$19.95

APPLE SOFTWARE buy any 3, take 10% off

Cat No.	Description	Price		Price
1317	Sargon Chess, 16K	19.95	1695	Tic-Tac-Talker/ Spectrum Analysis, 24K
1196	Bridge Challenger, 16K	14.95	1696	Bomber, 16K
1592	Bowling/Trilogy, 20K	7.95	1697	Rocket Pilot/ Saucer Invasion, 16K
1587	Golf, Applesoft II + 20K	7.95	1699	Star Wars/Space Maze, 16K
1701	Daily Biohythm, 16K	7.95	1693	Music Kaleidoscope, 16K
1656	Galactic Blockade Runner, 16K	9.95	1719	Personal Finance Package, 16K
1658	Sci-Fi Game Sampler, 16K	7.95	1697	Apple 21 (Black-jack), 16K
1662	Othello III, 16K	7.95		

TRS-80

16K TRS-80 MEMORY ADD-ON \$85

Installs in minutes! Everything you need to upgrade to 16K, 32K, or 48K. Guaranteed to work in your machine.

Cat No. 1156
For TRS-80 keyboard unit
Cat No. 1156-A
Exp. Inter. Prior to 4/1/79
Cat No. 1156-B
Exp. Inter. After 4/1/79

MATCHLESS SYSTEMS TRS-80 MINIDISK DRIVE \$395 2 for \$775

Faster accessing, increased data storage. Complete and ready to plug-in and go! Full 120 day MONEY BACK guarantee!

Cat No. 1375

TRS-80 SOFTWARE buy any 3, take 10% off

Cat No.	Description	Price		Price
1341	Fortran (Micro-soft) L2, 48K + disk	\$275.00	1481	Backgammon, L2, 16K
1725	CP/M, L2, 16K + disk	149.95	1048	Machine Language Monitor, L1/L2
1039	Renumbr 4K - 48K	14.95	1042	Tanot, L1/L2, 4K
1680	Renumbr, 16 - 48K + disk	19.95	1706	Music Master, L2 + 16K (plays music)
1549	Newdos +	99.95	1195	Bridge Challenger, L2 + 16K
1685	Electric Paintbrush	14.95	1186	Air Raid (real time target game) L1/L2 + 4K
1681	Syscop (copies SYSTEM tapes Level III Basic, L2 + 16K)	9.95	1577	Personal Finance Package, L1 + 4K, L2 + 16K
1332	Electric Pencil, cassette	49.00	1182	Microchess, L1/L2 + 4K
1338	TRS-232 Serial Interface	95.00	1046	The Game of Life, L1/L2 + 4K
1199	Star Trek III, L2, 16K	49.00		
1041		14.95		

COMPUTALKER SPEECH SYNTHESIZER

The finest low cost, high quality electronic speech synthesizer. Programmable to any language or dialect.

Cat No. 1917
For the TRS80 485.00

TRS-232 SERIAL INTERFACE

Software driver RS-232 output. Interface Diablo, Teletype, TI Silent, etc., without expansion interface!

Cat No. 1199 \$49.

TRS-80 DIN PLUGS 2 for \$1.50

Male, plugs into keybd unit & accessories.

Cat No. 1229

S-100

TARBELL

Cat No.	Description	Price
1756	Cassette Interface kit	\$120.00
1757	as above, add	175.00
1901	Floppy Disk Interface kit as above, bare-board	190.00
1774	as above, bare-board	39.00
1758	Disk Basic on CP/M disk	70.00
1902	Cassette BASIC	48.00
1773	32K Static Ram kit	620.00

CENTRONICS PARALLEL & SERIAL MICROPRINTERS

A non impact desktop microprinter perfectly suited for todays personal computers, microprocessor development systems, diagnostic systems, CRT hard copy and more! 40 column.

Cat No. 1843* Parallel \$445
Cat No. 1844* Serial \$515

S-100 EDGE CONNECTORS Buy any 3, take 10% off

Cat No.	Description	Price
1376	Imai type, soldertail	\$4.00
1428	Imai type, wire-wrap	4.25
1388	Altair type, soldertail	4.00

SSM COMPUTER BOARDS buy any 3, take 10% off

Cat No.	Description	Price		Price
1411	IO4 kit	\$139.00	1433	MB8A kit
1413	IO4 bb	26.00	1435	MB8A bb
1417	V818 kit	129.00	1436	MB9 kit
1419	V818 bb	26.00	1429	OB1 kit
1440	P81 kit	129.00	1431	OB1 bb
1408	S81 kit	150.00	1427	XB1
1410	S81 bb	35.00	1428	Connector for XB1
1400A	MB6B kit 450ns	139.00	1403	CB1 kit
1402	MB6B bb	26.00	1442	T1 (Terminator) kit
1405	MB7 kit	325.00	1414	IO2 kit
1407	MB7 bb	26.00	1416	IO2 bb
1425	MB3 kit	54.00		
1420	MB4 kit, 2 MHz	80.00		
1424	MB4 bb	26.00		

PET

SOUNDWARE

Add music and sound effects to YOUR computer programs. Complete system with speaker/amplifier unit, volume control, earphone jack and plug in connectors. Complete Demo and Sound Composer programs included.

Cat No. 1899 PET 29.95

PET

Cat No.	Description	Price
1823	8k bytes, large keyboard; numeric keypad and graphics on keys.	\$750
1824	16k bytes, large keyboard, numeric keypad and graphics on keys.	\$965
1825	32 bytes, large keyboard, no graphics on keys.	\$1165
1826	80 column dot matrix tractor feed printer	\$965
1827	Dual drive mini floppy system, 343k net user storage capacity	\$1088

PET SOFTWARE

buy any 3, take 10% off

Cat No.	Description	Price
1682	Basic Assembler for the PET	\$29.95
1713	PET Graphics	14.95
1661	Othello, 8K	7.95
1700	Daily Biohythm, 8K	7.95
1718	Personal Finance Package	9.95
1665	Bridge Challenger, 8K	14.95
1664	Microchess, 8K	19.95
1568	Qubic-4/Go-Moku, 8K	7.95
1564	Trek-X, 8K	7.95

Send for FREE CATALOG

Featuring:
The best selection of computer accessories add-ons, factory fresh IC's, led's, semi's, software, PC aids, prototyping aids, books, test equipment, and more! Always updated! Dozens of new products every issue!

Pay by check, COD, Visa, or MasterCard. Order by phone or mail. Minimum order \$10. Please include phone number and magazine/issue you are ordering from. USA: Add \$2 for shipping/handling ground, \$3 for air. FOREIGN: Add \$3 for surface, \$6 for air. COD's \$1 add'l. Guaranteed satisfaction for 120 days or your money back! Not responsible for typographical errors. We reserve the right to limit quantities.

Dept. B10 19511 Business Center Dr. Northridge, Ca. 91324

What's New?

SOFTWARE

Educational Software

This educational software for the Radio Shack Level II TRS-80 and Commodore PET is designed for educators utilizing computer-assisted instruction. Currently available software includes:

- Introduction to Microcomputers— 6 programs, 3 tapes plus teacher's guide; grades 1 through 8, at \$49.95.
- Basic Math Skill Games— 12 programs, 6 tapes plus teacher's guide; grades 1 through 8, at \$89.95.
- Word Problems, 6 programs, 3 tapes plus teacher's guide; primary grades, at \$54.95.
- Spelling I and II— 12 programs, 6 tapes, plus teacher's guide; primary grades, at \$54.95.

These complete supported programs make full use of the microcomputer's graphic capabilities and contain safeguards to minimize accidental program loss. All programs are loaded in individual cassette tapes and stored with support materials in a 3-ring notebook.



For more information, contact The Software Factory, 515 Park St, Anoka MN 55303.

Circle 603 on inquiry card.

T-Ball Jotter Disk for TRS-80

The T-Ball Jotter Disk contains software for use with 32 K byte TRS-80 disk and line printer systems. It contains a collection of business and professional programs which make many types of computations and prints out many forms used in the business and investment fields such as amortization schedules and financial statements. The disk has its own master control program which enables rapid selection among operations. The T-Ball Jotter Disk is priced under \$100. For more information, contact Contract Services Associates, 706 S Euclid, Anaheim CA 92802.

Circle 604 on inquiry card.

Pascal for the TRS-80

FMG Corp has announced a UCSD Pascal developmental package for Radio Shack's TRS-80. The FMG Pascal user's package is capable of running most business applications, such as word processing, payroll, accounting, and book-keeping.

The system supports up to four floppy disk drives, line printer and RS-232 serial interface. It also supports user-implemented peripherals. The FMG Pascal developmental package includes a compiler, Z80 assembler and screen editor. It is priced at \$150. For further information, contact the company at Suite 14, 5280 Trail Lake Dr, Ft Worth TX 76133.

Circle 605 on inquiry card.

PATH SYSTEMS, INC.		
PAYROLL PROGRAM CALCULATION		
	FPA-11	Others
Hourly Rate	3.75000000000000	3.75000000000000
Hours Worked	1.50000000000000	1.50000000000000
Wages	5.62500000000000	5.62500000000000
Internal Round-Up	+.005	+.005
Answer Generated	5.63000000000000	5.62999999999999
Check Printed	5.63	5.62

PDP-11 Compatible Floating Decimal Software Provides 14 Digit Accuracy

The FPA-11 Floating Decimal Arithmetic Package is a DEC PDP-11/LSI-11 compatible software program that generates answers as true decimal representations and completely eliminates strings of 9s. Offering 14 digit accuracy, it associates a scaling factor with each number to keep track of the decimal point as each calculation is performed. For fast execution, all calculations are conducted in binary form.

With a range of 10^{+14} , the package is characterized by compact internal representation, and manipulated numbers are internally represented by 4

words (8 bytes). Work space is defined local to an application, and several applications can use the package on a time-shared basis. A general purpose mode lets users bypass the decimal orientation when required.

The FPA-11 Floating Decimal Arithmetic Package is priced at \$75 on a floppy disk or cassette, and \$135 for RK-05 compatible media. Other media can be specified. Contact Path Systems Inc, The Millyard Bldg, 333 N Turner St, Manchester NH 03102.

Circle 606 on inquiry card.

File Management System

Called a Self-Indexing Query System, WHATSIT (Wow! How'd All That Stuff Get In There?) this file management system answers simple questions by referring to disk data that it stores and revises as instructed in short pidgin English sentences. Its entry-oriented indexing scheme is especially designed to combine maximum storage capacity with full cross-indexing. Applications of WHATSIT include desktop indexing of investment portfolios, music or hobby collections, customer lists, and household or professional files. Entries are automatically cross-indexed under any desired headings. Typical response time is 3 to 10 seconds.

Models are available for the Apple II and North Star systems (\$100) as well as for CP/M systems (\$150). Supplied on a ready-to-run disk, WHATSIT comes with a 150-page manual containing step-by-step instructions and numerous examples. Contact Computer Headware, POB 14694, San Francisco CA 94114.

Circle 607 on inquiry card.

The DATA-TRANS 1000

A completely refurbished
IBM Selectric Terminal with
built-in ASCII Interface.

\$1395

Features:

- 300 Baud
- 14.9 characters per second printout
- Reliable heavy duty Selectric mechanism
- RS-232C Interface
- Documentation included
- 60 day warranty - parts and labor
- High quality Selectric printing
- Off-line use as typewriter
- Optional tractor feed available
- 15 inch carriage width



**HOW TO ORDER
DATA-TRANS 1000**

1. We accept Visa, Master Charge. Make cashiers checks or personal check payable to:
DATA-TRANS
2. All orders are shipped F.O.B. San Jose, CA
3. Deliveries are immediate

For orders and information
DATA-TRANS
2154 O'Toole St.
Unit E
San Jose, CA 95131
Phone: (408) 263-9246

**MICRO-PROCESSORS:
FROM CHIPS TO
SYSTEMS**

This book cover all aspects of microprocessors, from the basic concepts to advanced interfacing techniques, in a progressive presentation. It is independent from any manufacturer, and presents uniform **standard** principles and design techniques, including the interconnect of a **standard** system, as well as specific components. It introduces the MPU, how it works internally, the system components (ROM, RAM, UART, PIO, others), the system interconnect, applications, programming, and the problems and techniques of system development. By R. Zaks. SYBEX. Ref. C201. \$9.95

**MICRO-PROCESSOR
INTERFACING
TECHNIQUES**

Microprocessor interfacing is no longer an art. It is a set of techniques, and in some cases just a set of components. This comprehensive book introduces the basic interfacing concepts and techniques, then presents in detail the implementation details, from hardware to software. It covers all the essential peripherals, from keyboard to floppy disk, as well as the standard buses (S100 to IEEE 488) and introduces the basic troubleshooting techniques. (2nd Expanded Edition). By Austin Lesea and R. Zaks. Ref. C207 SYBEX. \$11.95

**PROGRAMMING
THE 6502
PROGRAMMING
THE Z80
PROGRAMMING
THE 8080***

It covers all essential aspects of programming, as well as the advantages and disadvantages of the 6502 and should bring the reader to the point where he can start writing complete applications programs. For the reader who wishes more, a companion volume is available: The 6502 Applications Book. By R. Zaks. 6502: Ref. C202; Z80: Ref. C280; 8080: Ref. C208. SYBEX. Each \$10.95



**44 BUS MOTHER
BOARD**

Has provisions for ten 44 pin (.156) connectors, spaced 3/4 of an inch apart. Pin 20 is connected to X, and 22 is connected to Z for power and ground. All the other pins are connected in parallel. This board also has provisions for bypass capacitors. Board cost \$15.00 Part No. 102. Connectors \$3.00 each Part No. 44WP.



**AN INTRODUCTION
TO PERSONAL AND
BUSINESS
COMPUTING**

No computer background is required. The book is designed to educate the reader in all the aspects of a system, from the selection of the microcomputer to the required peripherals. By Rodney Zaks. Ref. C200. SYBEX \$6.95

TVT COOKBOOK

Bk 1064 — by Don Lancaster. Describes the use of a standard television receiver as a microprocessor CRT terminal. Explains and describes character generation, cursor control and interface information in typical, easy-to-understand Lancaster style. \$9.95

**COMPUTER
PROGRAMMING
HANDBOOK**

A complete guide to computer programming & data processing. Includes many worked-out examples. By Peter Staak. TAB \$9.95

**DIGITAL
CASSETTE**

5 min. each side. Box of 10 \$9.95. Part No. C-5.



To Order: Mention part no. description, and price. In USA shipping paid by us for orders accompanied by check or money order. We accept C.O.D. orders in the U.S. only, or a VISA or Master Charge no., expiration date, signature, phone no., shipping charges will be added. CA residents add 6.5% for tax. Outside USA add 10% for air mail postage and handling. Payment must be in U.S. dollars. Dealer inquiries invited. 24 hour order line (408) 448-0800



Send for FREE Catalog . . . a big self-addressed envelope with 41¢ postage gets it fastest!

ELECTRONIC SYSTEMS Dept. B, P. O. Box 21638, San Jose, CA USA 95151

COMPUCRUISE

Put a computer in your car, which gives you the most effective and functional cruise control ever designed, plus complete trip computing, fuel management systems, and a remarkable accurate quartz crystal time system.

So simple a child can operate, the new CompuCruise combines latest computer technology with state-of-the-art reliability in a package which will not likely be available on new cars for years to come. • Cruise Control • Time, E.T., Lap Timer, Alarm • Time, Distance, Fuel to Arrival • Time, Distance, Fuel to Empty • Time, Distance and Fuel on Trip • Current or Average MPG, GPH • Fuel Used, Distance since Fillup • Current and Average Vehicle Speed • Inside, Outside or Coolant Temperature • Battery Voltage • English or Metric Display. \$199.95



FLOPPY DISK STORAGE BINDER

This black vinyl three-ring binder comes with ten transparent plastic sleeves which accommodate either twenty, five-inch or ten, eight-inch floppy disks. The plastic sleeves may be ordered separately and added as needed. A contents file is included with each sleeve for easy identification and organizing. Binder & 10 holders \$14.95 Part No. B800; Extra holders 95¢ each. Part No. 800



OPTO-ISOLATED PARALLEL INPUT BOARD FOR APPLE II

There are 8 inputs that can be driven from TTL logic or any 5 volt source. The circuit board can be plugged into any of the 8 sockets of your Apple II. It has a 16 pin socket for standard dip ribbon cable connection.

Board only \$15.00, Part No. 120, with parts \$69.95. Part No. 120A.

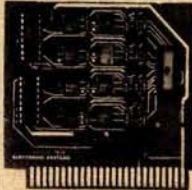

TIDMA

• Tape Interface Direct Memory Access • Record and play programs without bootstrap loader (no prom) has FSK encoder/decoder for direct connections to low cost recorder at 1200 baud rate, and direct connections for inputs and outputs to a digital recorder at any baud rate • S-100 bus compatible • Board only \$35.00 Part No. 112, with parts \$110 Part No. 112A



SYSTEM MONITOR

8080, 8085, or Z-80 System monitor for use with the TIDMA board. There is no need for the front panel. Complete with documentation \$12.95.

16K EPROM

Uses 2708 EPROMS, memory speed selection provided, addressable anywhere in 65K of memory, can be shadowed in 4K increments. Board only \$24.95 part no. 7902, with parts less EPROMs \$49.95 part no. 7902A.



ASCII KEYBOARD

TTL & DTL compatible • Full 67 key array • Full 128 character ASCII output • Positive logic with outputs resting low • Data Strobe • Five user-definable spare keys • Standard 22 pin dual card edge connector • Requires +5VDC, 325 mA. Assembled & Tested. Cherry Pro Part No. P70-05AB. \$135.00.



ASCII KEYBOARD

53 Keys popular ASR-33 format • Rugged G-10 P.C. Board • Tri-mode MOS encoding • Two-Key Rollover • MOS/DTL/TTL Compatible • Upper Case lockout • Data and Strobe inversion option • Three User Definable Keys • Low contact bounce • Selectable Parity • Custom Keycaps • George Risk Model 753. Requires +5, -12 volts. \$59.95 Kit.

ASCII TO CORRESPONDENCE CODE CONVERTER

This bidirectional board is a direct replacement for the board inside the Trendata 1000 terminal. The on board connector provides RS-232 serial in and out. Sold only as an assembled and tested unit for \$229.95. Part No. TA 1000C

DISK JACKET™

Made from heavy duty .0095 matte plastic with reinforced grommets. The mini-diskette version holds two 5-1/4 inch diskettes and will fit any standard three ring binder. The pockets to the left of the diskette can be used for listing the contents of the disk. Please order only in multitudes of ten. \$9.95/10 Pack.



INTERNATIONAL MICROPROCESSOR DICTIONARY

English, French, Danish, German, Italian, Hungarian, Norwegian, Polish, Spanish, Swedish. 10 languages, 28 pp. SYBEX. Ref. IMD. \$4.95

VIDEO TERMINAL

16 lines, 64 columns • Upper and lower case • 5x7 dot matrix • RS-232 in • RS-232 out with TTL parallel keyboard input • On board baud rate generator 75, 110, 150, 300, 600, & 1200 jumper selectable • Memory 1024 characters (7-21L02) • Video processor chip SFF96364 by Neculonic • Control characters (CR, LF, →, ←, ↑, ↓, non destructive cursor, CS, home, CL) • White characters on black background or vice-versa • With the addition of a keyboard, video monitor or TV set with TV interface (part no. 107A) and power supply this is a complete stand alone terminal • also S-100 compatible • requires +16, & -16 VDC at 100mA, and 8VDC at 1A. Part no. 1000A \$199.95 kit.



RS-232/20mA INTERFACE

This board has two passive, opto-isolated circuits. One converts RS-232 to 20mA, the other converts 20mA to RS-232. All connections go to a 10 pin edge connector. Requires +12 and -12 volts. Board only \$9.95, part no. 7901, with parts \$14.95 Part No. 7901A.



COMPUCOLOR II

Model 3, 8K \$13 95, Model 4, 16K \$15 95, Model 5, 32K \$18 95. Prices include color monitor, computer, and one disk drive.



PET COMPUTER

With 32K & monitor - \$1195. Dual Disk Drive - \$1195.



apple II or APPLE II PLUS

16K - \$995, 32K - \$1059, 48K - \$1123. Disk & cont. \$589



6502 APPLICATIONS BOOK 280 APPLICATIONS BOOK*

This book will teach you how to connect a board to the outside world and implement practical applications for the 6502, (or Z80). Applications range from home control (a complete alarm system, including heat sensor), to industrial applications. You will learn techniques ranging from simulated traffic control to analog-digital conversion. All experiments can be realized with a minimum of external (low-cost) components. They are directly applicable to any 6502-based board such as SYM, KIM, AIM 65. This book also studies in detail input-output techniques and components, and is the logical continuation of C202 (or C280). By Rodney Zaks. SYBEX. 6502: Ref. D302; Z80: Ref. D380. Each \$12.95

T.V. INTERFACE

• Converts video to AM modulated RF, Channels 2 or 3. So powerful almost no tuning is required. On board regulated power supply makes this extremely stable. Rated very highly in Doctor Dobbs' Journal. Recommended by Apple • Power required is 12 volts AC C.T., or +5 volts DC • Board only \$7.60 part No. 107, with parts \$13.50 Part No. 107A

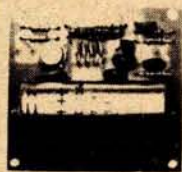

PARALLEL TRIAC OUTPUT BOARD FOR APPLE II

This board has 8 triacs capable of switching 110 volt 6 amp loads (660 watts per channel) or a total of 5280 watts. Board only \$15.00 Part No. 210, with parts \$119.95 Part No. 210A.

To Order: Mention part no. description, and price. In USA shipping paid by us for orders accompanied by check or money order. We accept C.O.D. orders in the U.S. only, or a VISA or Master Charge no., expiration date, signature, phone no., shipping charges will be added. CA residents add 6.5% for tax. Outside USA add 10% for air mail postage and handling. Payment must be in U.S. dollars. Dealer inquiries invited. 24 hour order line (408) 448-0800



Send for FREE Catalog . . . a big self-addressed envelope with 41¢ postage gets it fastest!

ELECTRONIC SYSTEMS Dept. B, P. O. Box 21638, San Jose, CA USA 95151

TRS-80 E.S. SERIAL I/O

- Can input into basic
- Can use LLIST and LPRINT to output, or output continuously
- RS-232 compatible
- Can be used with or without the expansion bus
- On board switch selectable baud rates of 110, 150, 300, 600, 1200, 2400, parity or no parity odd or even, 5 to 8 data bits, and 1 or 2 stop bits. D.T.R. line
- Requires +5, -12 VDC
- Board only \$19.95 Part No. 8010, with parts \$59.95 Part No. 8010A, assembled \$79.95 Part No. 8010 C. No connectors provided, see below.



EIA/RS-232 connector Part No. DB25P \$6.00, with 9' 8 conductor cable \$10.95 Part No. DB25P9.



3' ribbon cable with attached connectors to fit TRS-80 and our serial board \$19.95 Part No. 3CAB40.

RS-232/ TTL INTERFACE

- Converts TTL to RS-232, and converts RS-232 to TTL
- Two separate circuits
- Requires -12 and +12 volts
- All connections go to a 10 pin gold plated edge connector
- Board only \$4.50 Part No. 232, with parts \$7.00 Part No. 232A 10 Pin edge connector \$3.00 Part No. 10P

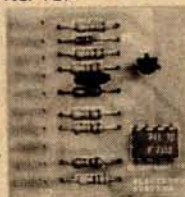

S-100 BUS ACTIVE TERMINATOR

Board only \$14.95 Part No. 900, with parts \$24.95 Part No. 900A



MODEM

- Type 103
- Full or half duplex
- Works up to 300 baud
- Originate or Answer
- No coils, only low cost components
- TTL input and output
- Connect 8 Ω speaker and crystal mic. directly to board
- Uses XR FSK demodulator
- Requires +5 volts
- Board only \$7.60 Part No. 109, with parts \$27.50 Part No. 109A

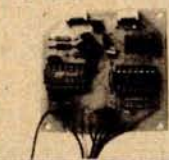

DISKETTES



Box of 10, 5" \$29.95, 8" \$39.95.
Plastic box, holds 10 diskettes, 5" - \$4.50, 8" - \$6.50.

RS-232/TTY INTERFACE

This board has two active circuits, one converts RS-232 to 20mA, and the other converts 20mA to RS-232. Requires +12 and -12 volts. Board only \$4.50 Part No. 600, with parts \$7.00 Part No. 600A.

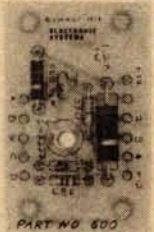

APPLE II[®] SERIAL I/O INTERFACE



Baud rate is continuously adjustable from 0 to 30,000

- Plugs into any peripheral connector
- Low current drain. RS-232 input and output
- On board switch selectable 5 to 8 data bits, 1 or 2 stop bits, and parity or no parity either odd or even
- Jumper selectable address
- SOFTWARE
- Input and Output routine from monitor or BASIC to teletype or other serial printer
- Program for using an Apple II for a video or an intelligent terminal. Also can output in correspondence code to interface with some electrics.
- Also watches DTR
- Board only \$15.00 Part No. 2, with parts \$42.00 Part No. 2A, assembled \$62.00 Part No. 2C

8K EPROM PICEON

Saves programs on PROM permanently (until erased via UV light) up to 8K bytes. Programs may be directly run from the program saver such as fixed routines or assemblers.

- S-100 bus compatible
- Room for 8K bytes of EPROM non-volatile memory (2708's)
- On-board PROM programming
- Address relocation of each 4K of memory to any 4K boundary within 64K
- Power on jump and reset jump option for "turnkey" systems and computers without a front panel
- Program saver software available
- Solder mask both sides
- Full silkscreen for easy assembly. Program saver software in 1 2708 EPROM \$25, Bare board \$35 including custom coil, board with parts but no EPROMS \$139, with 4 EPROMS \$179, with 8 EPROMS \$219.

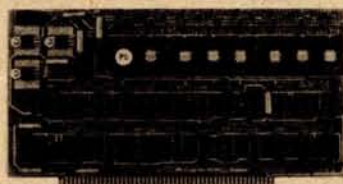

WAMECO PRODUCTS WITH ELECTRONIC SYSTEMS PARTS

FDC-1 FLOPPY CONTROLLER BOARD will drive shugart, pertek, remex 5" & 8" drives up to 8 drives, on board PROM with power boot up, will operate with CPM (not included). PCBD \$42.95

FPB-1 Front Panel. (Finally) IMSAI size hex displays. Byte or instruction single step. PCBD \$42.95

MEM-1A 8Kx8 fully buffered, S-100, uses 2102 type RAMS. PCBD \$24.95, \$168 Kit

QMB-12 MOTHER BOARD, 13 slot, terminated, S-100 board only \$34.95 \$89.95 Kit

CPU-1 8080A Processor board S-100 with 8 level vector interrupt PCBD \$25.95 \$89.95 Kit

RTC-1 Realtime clock board. Two independent interrupts. Software programmable. PCBD \$25.95, \$60.95 Kit

EPM-1 1702A 4K EPROM card PCBD \$25.95 \$49.95 with parts less EPROMS

EPM-2 2708/2716 16K/32K EPROM card PCBD \$24.95 \$49.95 with parts less EPROMS

QMB-9 MOTHER BOARD. Short Version of QMB-12. 9 Slots PCBD \$30.95 \$67.95 Kit

MEM-2 16Kx8 Fully Buffered 2114 Board PCBD \$25.95, \$269.95 Kit

T.V. TYPEWRITER

- Stand alone TVT
- 32 char/line, 16 lines, modifications for 64 char/line included
- Parallel ASCII (TTL) input
- Video output
- 1K on board memory
- Output for computer controlled cursor
- Auto scroll
- Non-destructive cursor
- Cursor inputs: up, down, left, right, home, EOL, EOS
- Scroll up, down
- Requires +5 volts at 1.5 amps, and -12 volts at 30 mA
- All 7400, TTL chips
- Char. gen. 2513
- Upper case only
- Board only \$39.00 Part No. 106, with parts \$145.00 Part No. 106A



UART & BAUD RATE GENERATOR

- Converts serial to parallel and parallel to serial
- Low cost on board baud rate generator
- Baud rates: 110, 150, 300, 600, 1200, and 2400
- Low power drain +5 volts and -12 volts required
- TTL compatible
- All characters contain a start bit, 5 to 8 data bits, 1 or 2 stop bits, and either odd or even parity.
- All connections go to a 44 pin gold plated edge connector
- Board only \$12.00 Part No. 101, with parts \$35.00 Part No. 101A, 44 pin edge connector \$4.00 Part No. 44P

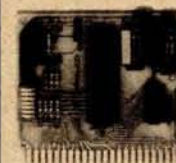

TAPE INTERFACE

- Play and record Kansas City Standard tapes
- Converts a low cost tape recorder to a digital recorder
- Works up to 1200 baud
- Digital in and out are TTL
- serial
- Output of board connects to mic. in of recorder
- Earphone of recorder connects to input on board
- No coils
- Requires +5 volts, low power drain
- Board only \$7.60 Part No. 111, with parts \$27.50 Part No. 111A

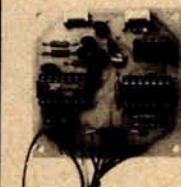

HEX ENCODED KEYBOARD

E.S. This HEX keyboard has 19 keys, 16 encoded with 3 user definable. The encoded TTL outputs, B-4-2-1 and STROBE are debounced and available in true and complement form. Four onboard LEDs indicate the HEX code generated for each key depression. The board requires a single +5 volt supply. Board only \$15.00 Part No. HEX-3, with parts \$49.95 Part No. HEX-3A. 44 pin edge connector \$4.00 Part No. 44P.



DC POWER SUPPLY

- Board supplies a regulated +5 volts at 3 amps., +12, -12, and -5 volts at 1 amp.
- Power required is 8 volts AC at 3 amps., and 24 volts AC C.T. at 1.5 amps.
- Board only \$12.50 Part No. 6085, with parts excluding transformers \$42.50 Part No. 6085A



To Order: Mention part no. description, and price. In USA shipping paid by us for orders accompanied by check or money order. We accept C.O.D. orders in the U.S. only, or a VISA or Master Charge no., expiration date, signature, phone no., shipping charges will be added. CA residents add 6.5% for tax. Outside USA add 10% for air mail postage and handling. Payment must be in U.S. dollars. Dealer inquiries invited. 24 hour order line (408) 448-0800



Send for FREE Catalog ... a big self-addressed envelope with 41¢ postage gets it fastest!

ELECTRONIC SYSTEMS Dept. B, P. O. Box 21638, San Jose, CA USA 95151

ADVANCED COMPUTER PRODUCTS

P.O. Box 17329, Irvine, CA 92713
(714) 558-8813

BACK TO SCHOOL COMPUTER SPECIALS

... and it's COLOR SALE \$100.00 OFF

"The Compucolor II"

... a personal colorgraphics system for the modern computer man ...

- ★ Color Graphics 13" Color CRT
- ★ Proven 8080A CPU System
- ★ 16K Extended Disk Basic
- ★ Up to 117* Key Keyboard
- ★ Up to 32K* RAM
- ★ Minidisk Drive 51.2K Bytes/Side



*option

Model 3 w/8K, 72 Key Keyboard, RS232	SALE TAKE OFF	\$1495.00
Model 4 w/16K, 72 Key Keyboard, RS232		\$1695.00
Model 5 w/32K, 72 Key Keyboard, RS232		\$1995.00
Options: 101 Key Keyboard	Add	\$150.00
117 Key Keyboard	Add	\$225.00
Formatted Diskettes	2/\$	19.95
Programmed Diskettes		\$19.95
Diskette Library Inc. Hangman, Othello, Math, Chess, Startrek, Blackjack, Cubic Tic Tac Toe, Finance Vol. I, Finance Vol. II, Bonds and Securities, Assembler, Text Editor, Personal Data Base.		

EXIDY SORCERER ONLY \$799.00



\$799 w/8K
\$1099 w/16K
\$1249 w/32K
\$1449 w/48K

User programmable or use cartridges. Combines the desirable features of the PET, APPLE and TRS-80 into a complete expandable computer system.

- ★ I/O expansion kit \$149.00
- ★ Vista V-200 add-on minifloppy for Exidy. (requires exp. module) w/CPM \$699.00
- ★★ New Word Processing Pac \$99.00

★ INCLUDES:
Keyboard & enclosure
90 day Warranty
MICROSOFT BASIC
Video & Cassette Cable
Complete Documentation

- ★★ \$100 Expansion Module Add \$299.00
- ★★ Cassette recorder Add \$44.95
- ★★ Sanyo 9" Monitor Add \$169.95

KIM-1

Now only **\$179.00**



- ★★ Power Supply Add \$59.95
- ★★ Cassette Recorder Add \$44.95
- ★★ Sanyo 9" Monitor Add \$169.95
- Add enclosure \$29.95.

SYM-1 IN STOCK

Reg. \$269.00
Now **\$249.00**



- ★ KIM-1 Compatible
- ★ 4K ROM Monitor
- ★ 1K Bytes 2114 RAM
- ★ 65K Memory Expansion
- ★ User EPROM 2716
- ★★ Power Supply Add \$59.95
- ★★ Cassette Recorder Add \$44.95
- ★★ Sanyo 9" Monitor Add \$169.95

School & group discounts available. Buy now and receive \$100.00 worth of discount coupons: i.e.,

- ★ SRM-1 1K Static RAM exp. reg. 42.00 disc. \$32.00
- ★ PEX-1 I/O Port, reg. \$60.00, disc. \$50.00
- ★ SYM BAS-1 Basic ROM (Microsoft) reg. \$159.00 disc. \$109.00
- ★ KTM-2 CRT/TV Keyboard, reg. \$349.00 disc. \$319.00
- ★ SYM Enclosure \$39.95

AIM 65

\$375.00



ADVANCED INTERACTIVE MICROCOMPUTER

- ★ On Board 20 column alphanumeric printer
- ★ Alphanumeric 20 character display
- ★ Terminal style Keyboard 54 Keys
- ★ 6502 based CPU

w/1K RAM \$375.00*
w/4K RAM \$450.00*
Assembler ROM ... Add \$85.00
BASIC IN ROM ... Add \$100.00
Power Supply Add \$99.95
Enclosure Add \$44.95

RCA COSMAC VIP



NEW LOW PRICE **\$249.00**

Assembled. Regular price \$299.95
w/Sanyo 9" Monitor \$169.95

- VP-590 Color Board 69.95
- VP-595 Sound Board 49.95
- VP-570 4K Expansion Board 95.95
- VP-580 Expansion Keyboard 15.95
- VP-700 Tiny Basic ROM 49.95
- VP-710 VIP Game Manual 10.95

LOW LOW APPLE II PLUS \$990.00

APPLE's new upgraded APPLE II w/16K is now in stock and available for the lowest price ever, only \$990.00. You can add:

- ★★ M & R Modulator for \$29.95
- ★★ Sanyo tape recorder for \$44.95
- ★★ 16K upgrade kit for only \$74.95 ea.

This is a limited offer and we reserve the right to change without notice.

NORTH STAR HORIZON ★DOUBLE DENSITY★

Now in stock North Star Z-80-based high-performance computer.

- ★ 180K Bytes per Disk
- ★ Z-80 Processor
- ★ Motherboard
- ★ 2 Serial +1 Parallel Port Avail.
- ★ 16K RAM

Horizon I Kit Reg. \$1599.00 Sale \$1349.00
Horizon II Kit Reg. \$1999.00 Sale \$1749.00



North Star Double Density Disk Subsystem Kit

PROCESSOR TECHNOLOGY SALE

SOL-20 DEALERS & USERS INVITED!

We purchased Processor Technology's entire inventory of spare parts, work in process, and finished goods. This material will be sold on a first come first served basis. Advanced will continue to support some SOL products on a limited basis so make sure you get a copy of our complete inventory listing and a place on our SOL mailing list.

- ★ New SOL-20 w/o Memory \$1295.00
- ★ SOL-20 Keyboards \$139.95
- ★ 8KRA Memory Boards Assembled \$129.95
- ★ NKRA Memory Boards up to 64K \$CALL

Plus more endless PTI bargains send for details.

HERE ARE SOME EXAMPLES

1979 CATALOG NOW AVAILABLE FOR ONLY \$1.00

Widen the ability of your TRS-80



The Vista V80: \$395

The Vista V80 Mini Disk System is the perfect way to widen the capabilities of your TRS-80* Micro-computer. Quickly and inexpensively. Our \$395 price tag is about \$100 less than the Radio Shack equivalent. Our delivery time is immediate (24 hour turn-around from our Santa Ana, Ca. factory). And our system is fully interchangeable. That's just the start.

It will give you 23% more storage capacity by increasing useable storage from 55,000 to 65,000 bytes per drive with our new software patch.

It can work 8 times faster than the TRS-80 Mini-Disk system, because track-to-track access is 5ms versus 40ms for the TRS-80. You can realize this added speed

once the new double disk expansion interface is available without expensive modification of the existing unit.

It has a better warranty than any comparable unit warranty available – a full 120 days on all parts and service. When you consider how much more goes into the Vista V80, that shows a lot of faith in our product.

A full 3 amp power supply means you have 2½ times the power necessary to operate the V80, and full ventilation insures that there will be no problems due to overheating.

The Vista V80 Mini Disk System requires Level II Basic with 16K RAM Expansion interface (it operates from the Radio Shack interface system. It

comes complete with a dependable MPI Minifloppy disk drive, power supply, regulator board and vented case. It's shipped to you ready to run – simply take it out of the box and plug it in. You're in business. From the company that means business – Vista Computer Company.



The Vista Computer Company.
Manufacturers of Quality
Computer Systems
and Software.

714/751-9201
1320 East St. Andrews Place
Suite I, Santa Ana, Ca. 92705

NEW 32K EPROM/RAM MEMORY CARD

SS-50
BUS
5V
only

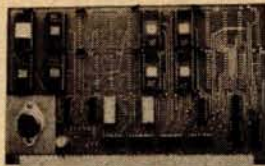

DSD PIR-32K \$27.00
2716 EPROMS & TMS 4016 2K x 8 Static RAM.
4 Independent 8K memory blocks. Size 9" x 5".

DSD 2114-16K \$27.00
16K Static RAM memory card using the 2114 or TMS 4045
1K x 4 Static RAMS. Size 9" x 5".
2 Independent 8K memory blocks. 5V only.

NEW DSD U P 8255 (C & M) \$14.00
Universal parallel interface card for Both the SWTP 30 pin I/O
BUS (M) & the DSD 27 pin BUS (C). Utilizes INTEL'S 8255
PROGRAMMABLE I/O chip. Wire wrap area for full UTILIZATION
of the 8255. Card size 5 1/2" x 5" (M), 5 1/2" x 4 1/4" (C).

ALL cards are bare board with edge connectors & Data.



DIGITAL SERVICE & DESIGN

P.O. BOX 741

NEWARK, OHIO 43055

Ohio residents add 4.5% sales tax.

M/C &
VISA

Circle 102 on inquiry card.

SURPLUS ELECTRONICS

ASCII



ASCII

IBM SELECTRIC
BASED I/O TERMINAL
WITH ASCII CONVERSION
INSTALLED \$645.00

- Tape Drives • Cable
- Cassette Drives • Wire
- Power Supplies 12V15A, 12V25A, 5V35A Others, • Displays
- Cabinets • XFMRs • Heat Sinks • Printers • Components

Many other items

Write for free catalog

WORLDWIDE ELECT. INC.

130 NORTHEASTERN BLVD.

NASHUA, N.H. 03060

Phone orders accepted using VISA

or MC. Toll Free 1-800-258-1036

In N.H. 603-889-7661

Circle 391 on inquiry card.

GLARE FILTER

HIGH CONTRAST
SHARP RESOLUTION
MICRO-POROUS OPTICAL FILTER
FOR HOME COMPUTER CRT'S

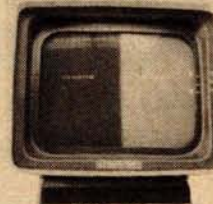

With Filter

No Filter

TRS 80	19.95	PET	19.95
ADM 3A	19.95	Sorac 10 120	19.95
Hazeltine		Southwest Tech.	19.95
1400-1500	19.95	Micro-Term	
Perkin Elmer	19.95	Act V	19.95

Easily Installed • Instructions Included
For information on other models
dial (415) 456-8909

SUN-FLEX COMPANY, INC.

3020 Kerner Blvd. • San Rafael, CA 94901
Check/money order Visa/Mastercharge

Circle 343 on inquiry card.

Memorex Floppy Discs

Lowest prices. **WE WILL NOT BE UNDERSOLD!** Buy any quantity 1-1000. Visa, Mastercharge accepted. Call free (800)235-4137 for prices and information. All orders sent postage paid.

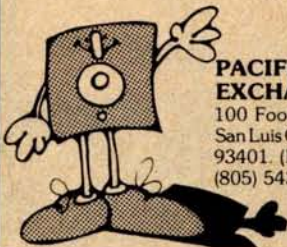

PACIFIC
EXCHANGES
100 Foothill Blvd.
San Luis Obispo, CA
93401. (In Cal. call
(805) 543-1037.)

Circle 294 on inquiry card.

FLOPPY DISK REPAIR



- PerSci and Shugart
- Quick turnaround
- Factory trained on PerSci



COMPUTER SERVICE CENTER

7501 Sunset Blvd

Hollywood CA 90046

213-851-2226

Circle 68 on inquiry card.



6800 DEVELOPMENT PAC I

- CONTROL MODULE-single board computer
- 16K RAM MODULE-16K 8-bit bytes
- RS232 INTERFACE-switchable rates
- CASSETTE INTERFACE-300/2400 baud
- FANTOM-II monitor/debug ROM
- EDITOR/ASSEMBLER-on cassette
- CARD RACK, BACK PLANE, POWER SUPPLY
- \$895

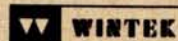

Corp.

Phone: 317-742-8428

1801 South St., Lafayette, IN 47904

Circle 389 on inquiry card.

tinyFORTH

tinyFORTH is the TRS-80 cassette oriented version of the dictionary based computer language called FORTH.

tinyFORTH includes these features:

- ✓ Dictionary-oriented structured high-level language
- ✓ Built-in assembler and text editor
- ✓ Enhanced graphics
- ✓ Cassette tape input and output
- ✓ Interpreter for quick program development
- ✓ Compiler for fast execution
- ✓ tinyFORTH is faster, more compact, and more powerful than BASIC
- ✓ tinyFORTH and FORTH programs are interchangeable
- ✓ Easy to use.

tinyFORTH cassette for 16K TRS-80 and full documentation \$29.95
Documentation Only \$9.95

All orders are fully guaranteed. Add \$1.50 for postage and handling. Order with check, money order, COD, Visa, or Mastercharge. Specify TRS-80 level when ordering.

The Software Farm

Box 2304 Dept. A2 Reston, VA 22090

Circle 333 on inquiry card.

O.S.I.

RS-232 KIT FOR C1P'S & C2-4P'S

- * EASY TO FOLLOW STEP BY STEP INSTRUCTIONS
- * ALL PARTS INCLUDED
- * ONLY \$35 COMPLETE
- * FULL GUARANTEE

FARAGHER & ASSOCIATES

7635 BLUEMOUND
MILWAUKEE, WI 53213
(414) 258-2588

Circle 138 on inquiry card.

6809



6809

MONOBOARD COMPUTERS EXORCISERS* / MICROMODULE* BUS

MIKUL 6809-1

3 PIAS, 1 K RAM, 4/8 K EPROMS

MIKUL 6809-2

2 PIAS, 2 ACIAs, 2 K RAM (BATTERY BACKED) 4/8 EPROMS

MIKUL 6809-3

1 PTA (6840), 2 PIAS, 1 ACIA, 2 K RAM (BATTERY BACKED), 4/8 K EPROMS

T9 BUG MONITOR

*Trademark of Motorola

TL INDUSTRIES, INC.
NORTHWOOD, OHIO
419-666-8144

Circle 374 on inquiry card.

The COMPUTER FACTORY

TO ORDER CALL TOLL FREE 800-223-7318

NEW PET BUSINESS SYSTEM

PET 2001 - 16/32K

The PET is now a truly sophisticated Business System with the announcement of the Floppy Disk and Printer. This is an ideal business system for most professional and specialized fields: medicine, law, dental, research, engineering, toolmaking, printing, education, energy conservation, etc. . . . The PET Business System as a management tool, delivers information to all levels of Business, previously attainable only with equipment many times more expensive. The PET Business System is one of the most cost efficient business tools today. Here are just a few of the cost-saving uses in the corporation, professional office or small business: stock control, purchasing, forecasting, manufacturing costing, customer records, mailing lists, etc. . . .

Features Include:

- 16 or 32K bytes RAM user memory
- 14K ROM operating system including a machine language monitor
- Full-sized Business Keyboard
- Upper/Lower case and 64 graphics characters
- 9-inch CRT
- 8K ROM expansion sockets
- File management in operating system

**16K - \$995,
32K - \$1295**



Model 2040
\$1295

DUAL DRIVE FLOPPY DISK 2040

The Dual Drive Floppy is the latest in Disk technology with extremely large storage capability and excellent file management. As the Commodore disk is an "Intelligent" peripheral, it uses none of the RAM (user) memory of the PET. The Floppy Disk operating system used with the PET computer enables a program to read or write data in the background while simultaneously transferring data over the IEEE to the PET. The Floppy Disk is a reliable low cost unit and is convenient for high speed data transfer. Due to the latest technological advances incorporated in this

disk, a total of 360K bytes are available in the two standard 5 1/4-inch disks, without the problems of double tracking or double density. This is achieved by the use of two microprocessors and fifteen memory IC's built into the disk unit.

Features Include:

- 360K bytes storage
- 6504 microprocessor-controlled
- 8K operating system in ROM
- 4K encoder and decoder in ROM
- 4K RAM
- Uses single or double sided floppies



MODEL 2022
\$995

TRACTOR FEED PRINTER 2022

The Tractor Feed Printer is a high specification printer that can print onto paper (multiple copies) all the PET characters - letters (upper and lower case), numbers and graphics available in the PET. The tractor feed capability has the advantage of accepting mailing labels, using standard preprinted forms (customized), check printing for salaries, payables, etc. The PET is programmable, allowing the printer to format print

for: width, decimal position, leading and trailing zero's, left margin justified, lines per page, etc. It accepts 8 1/2-inch paper giving up to four copies.

Features Include:

- 150 cps
- 6504 microprocessor-controlled
- Bottom and rear tractor feed
- 1/2K RAM buffer
- 4K operating system in ROM

Model 2023 (Friction Feed) - \$849

**CABLE FROM PET TO DISK OR PRINTER - \$39
CABLE FROM PRINTER TO DISK - \$49**

(Next day delivery available.)

FULL SYSTEM NOW IN STOCK FOR IMMEDIATE DELIVERY!

SUPER WORD PROCESSING SYSTEM

**\$2395 complete
with software**

System Includes:

- 16K PET with Full Sized Keyboard
- Tape Drive Unit

- Anderson Jacobson 841 Selectric Printer
- Interface
- Super Word Processing Software

The Super Word Processing System is written in 6502 Assembly Language! It allows anyone to use the PET computer for such tasks as typing letters, reports, and manuscripts, for producing mailing lists, and for filling out forms. The software is written to support any inexpensive printer and even high performance printers with incremental and proportional letter spacing. The Super Word Processor easily creates, edits, rearranges, and formats text. It can merge multiple texts. In addition to search commands, the system has automatic text wrap-around, which eliminates the need for carriage returns. The system uses a holding buffer to rearrange blocks

anywhere on the page. Up and down screen scrolling makes editing a breeze! Commands include end-to-end cursor line SCAN, INDENT, TAB, soft HYPHEN for splitting syllables at the end of a line, and four-direction cursor control. Output formatting includes dynamic print control, indentation, right justification, line width and line-to-line spacing and proportional letterspacing.

Also included are programming capabilities for performing such useful tasks as a direct-mail form-letter typing, multiple column printing, and automatic multiple forms entry. You may obtain this system in a cassette or disk drive version.

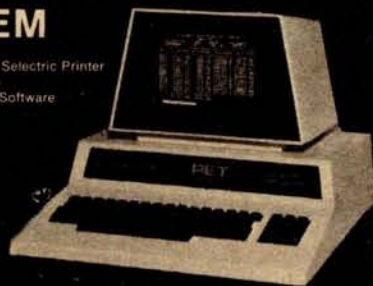

BUSINESS SOFTWARE FOR PET BUSINESS SYSTEM

- Super Word Processing Package (Disk \$99.95, Tape \$24.95)
- Real Estate \$ 65
- Statistics
- Banking & Finance
- Mail List Management \$125
- Data Base System \$125
- KRAM - Keyed (index sequential) random access method. Written in 6502 machine code. Gives PET disk true random access. . . . \$75
- Small Business Package (A/R, A/P, G/L)
- General Ledger \$195
- Cash Receipts & Disbursements \$125
- Inventory Control \$100
- Payroll w/cost acct'g. . . . \$100

PERIPHERALS FOR PET

- 24K Memory Expansion \$499
- 16K Memory Expansion 399
- PET to RS232 Serial 169
- 2 Way Serial Communication 229
- Modern Board for PET 375
- Analog to Digital Board for 16 Devices 275
- Second Cassette Drive 95
- Parallel Printer Interface 169

NEW! from Eventide

AUDIO SPECTRUM ANALYZER

- Mounts inside the PET
- Third-Octave audio spectve analysis
- Complete with software and documentation
- Replaces equipment costing thousands of dollars

\$595



PET MUSIC BOX from SOUNDWARE

Add music and sound effects to your programs. Compose, play, and hear music on your PET. Completely self-contained Free programs **\$29.95**



MARK SENSE CARD READER

\$750

- Automatic turn-on and card feed
- Ideal for marking test scores
- Accepts any length card
- Perfect for schools & business



N.Y. residents add 8% sales tax • Same day shipment on prepaid and credit card orders • Add \$5 shipping for computers, \$3 for boards, \$1 each cassette tape.



Min Credit Card Order \$75

Open Mon-Fri 10-6 Sat 10-4

TO ORDER CALL TOLL FREE 800-223-7318

(46th St.)

The COMPUTER FACTORY

485 Lexington Avenue 750 Third Avenue New York, N.Y. 10017
(212) 687-5001 (212) PET-2001 Foreign order desk - Telex 640055

The COMPUTER FACTORY

TO ORDER CALL TOLL FREE 800-223-7318



FINALLY TEXAS INSTRUMENTS TI-99/4 Home Computer
Many Peripherals. Coming soon!

- 16-bit microprocessor
- 16K RAM
- 13" color monitor (24 lines of 32 chrs.)
- 26K ROM operating system (Includes 14K BASIC)
- Sound - 3 tones, 5 octaves
- 16 colors: 192 x 256 res.
- Large TI library of ROM programs available.

only **\$1150**
Includes 13" Color Monitor!



\$1495 Complete!
16K Model add \$200
32K Model add \$500

CompuColor II

COMPUCOLOR II Disk-Based Model 3 Advanced hardware and software technology gives you

- 13" Color Display
- Advanced Color Graphics
- 51K Disk Built-In
- 16K ROM Operating System
- 8K RAM User Memory
- 4K RAM Refresh
- 8080A Microcomputer
- RS-232 I/O

Over 1000 software tapes, books, disks on display.
Come in and browse.

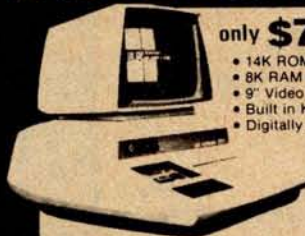

only **\$795**

- 14K ROM Operating system
- 8K RAM Memory
- 9" Video Monitor
- Built in Keyboard
- Digitally controlled tape

'PET' COMMODORE

★ **SPECIAL SPECIAL**
\$200 FREE Software with purchase of 8K PET ★



NEW!

APPLE II PLUS ONLY \$1195

A complete self-contained computer system with APPLESOFT floating point BASIC in ROM, full ASCII keyboard in a light weight molded carrying case.

Features Include:

- auto-start ROM • Hi-Res graphics and 15 color video output.
- Expandable to 48K.

Disk	\$595	Programmer's Aid	50
Add-on Disk	495	Speechlab	229
Pascal Card	495	Lightpen	250
Business Software	625	Communication Card	225
Monitor	149	Modem	200
Printer Card	180	EPROM Programmer	100

NEW D. C. Hayes MICROMODEM II

- Combines the capabilities of a communications card and acoustic coupler.
- Plugs directly into Apple slot and modular telephone jack.
- Auto dial/receiver • FCC approved

only **\$379**

NEW Mountain Hardware SUPERTALKER

- Digitized speech recording and playback.
- Must be heard to be believed!
- Foreign language teaching pack available.
- Software compatible.

only **\$279**

SUPERBRAIN™

INTERTEC DATA SYSTEMS

ONLY **\$2995**

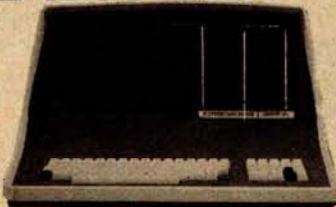

More than an intelligent terminal, the SuperBrain outperforms many other systems costing three to five times as much. Endowed with a hefty amount of available software (BASIC, FORTRAN, COBOL), the SuperBrain is ready to take on your toughest assignment. You name it! General Ledger, Accounts Receivable, Payroll, Inventory or Word Processing... the SuperBrain handles all of them with ease.

Features Include:

- two dual-density minifloppies with 320K bytes of disk storage
- 64K of RAM to handle even the most sophisticated programs
- a CP/M Disk Operating System with a high-powered text editor, assembler and debugger.

FREE \$35 of Software with purchase of any computer on this page.

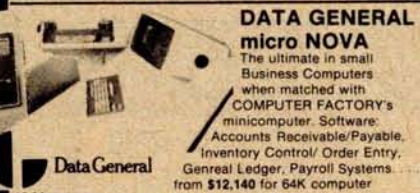

DATA GENERAL micro NOVA

The ultimate in small Business Computers when matched with COMPUTER FACTORY's minicomputer. Software: Accounts Receivable/Payable, Inventory Control/ Order Entry, General Ledger, Payroll Systems... from \$12,140 for 64K computer

10 Megabyte System \$17,040 with cabinet, printer terminal, video terminal, dual disk and multi-user operating system!

NEW! CENTRONICS 704

- 180 cps Bi-Directional
- Upper/Lower Case
- 9 x 9 Matrix
- Tractor Feed
- Up to 15" Paper Width
- RS-252 Serial Interface



CENTRONICS 753

- New Word Processing Dot Matrix Printer
- 130-150 cps • Proportional Spacing
- Tractor Feed • N x 9 Matrix

Call for Special prices

SOUNDWARE MUSIC BOX only \$29.95

Music and Sound Effects for PET, TRS-80, & CompuColor II Add music and sound effects to your programs. Compose, play, and hear music on your computer. Completely self-contained. Free programs



Moving Average Plot Program FOR APPLE

This fantastic program disk allows the statistician, mathematician, trader in stocks, money or commodities, the ability to maintain 30 database series of up to 300 values and plot 3 different moving averages of a series at the same time, in 3 different colors. Files can be updated, deleted, changed, extended, etc.
A sure value disk at only \$40!
Word Processing For Apple on disk... \$50



SORCERER

SPECIAL 12" Video Monitor for SORCERER (\$299 value) ONLY

\$125 with 8K unit
95 with 16K unit
65 with 32K unit

- by EXIDY
- 2.80 Processor
 - Keyboard and Numeric Pad
 - 8K RAM (up to 32K)
 - Serial and Parallel I/O
 - Dual Cassette I/O
 - 30 x 64 Display
 - 5100 Computer
 - 64 User Defined Characters
 - 240 x 512 Resolution Graphics
- Modular design allows use of both cassettes for programs and ROM PAC cartridges for future language introductions like: APL, COBOL, PILOT, FORTRAN, etc. Add monitor and tape or disk for complete computer system

8K \$ 995
16K \$1145
32K \$1295
48K \$1445

ANDERSON JACOBSON



841 I/O Terminal
Ideal for word processing and small businesses.
• ASC II Code
• 15 cps Printout
• High Quality Selective Printing
• Use Keyboard for PET
• Reliable heavy duty Mechanism
• Completely Refurbished by A.J.
• Service in 15 Major Cities
Plus \$35 Freight-In Charge

NOW IN STOCK!

Parallel \$1095
Serial \$1195

RADIO SHACK • PET • SORCERER • APPLE • COMPUCOLOR • ETC. PRINTERS • PRINTERS • PRINTERS

The COMPUTER FACTORY'S extensive inventory and wide selection of computer printers assures you of finding the printer best suited for your needs and specifications. The following printers work well with all known personal computers.

CENTRONICS 779	945
TRENDCOM 100	375
TRENDCOM 200	595
INTEGRAL DATA	795
PAPER TIGER 440	995
COMPRINT	560

Master Card Min Credit Card Order \$75

VISA Open Mon.-Fri. 10-6 Sat. 10-4

N.Y. residents add 8% sales tax • Same day shipment on prepaid and credit card orders
• Add \$5 shipping for computers. \$3 for boards. \$1 each cassette tape.

NEW CENTRONICS 730
50 CPS - MICROPROCESSOR CONTROLLED!
Tractor & Friction Feed • Uses Single Sheets, Roll, Fanfold • Upper & Lower Case • Light Weight
Parallel \$995
Serial \$1045

SPECIAL SALE
Buy any computer and take 10% off price of printer of your choice

TO ORDER CALL TOLL FREE 800-223-7318
The COMPUTER FACTORY 485 Lexington Avenue 750 Third Avenue New York, N.Y. 10017
(212) 687-5001 (212) PET-2001 Foreign order desk - Telex 640055



- **APPLE II or APPLE II PLUS** \$1019.95
- **DC HAYES MODEMS** 339.95
- **FLOPPY DISK W/CONT.** 529.95
- **APPLE SOFT CARD** 159.95
- **PASCAL CARD** 459.95
- **ALF MUSIC SYNTHESIZER** 249.95
- **10 MEGA-BYTE DISK DRIVE (for APPLE)** 4695.00

UCATAN COMPUTER STORE
across from Ramada Inn
 PO Box 1000
 Destin, Florida 32541
 (904) 837-2022 or (904) 243-8565

Circle 309 on inquiry card.

FIELD ENGINEERS

Never sell yourself short!
 If you fix computers and their peripherals, and it is time for a job change, let

FIELD SERVICE SEARCH

locate the best opportunities for you. Employer pays fees. Call collect (312) 398-5535.

Address:

FIELD SERVICE SEARCH
 925 E. Rand Road
 Arlington Heights, IL 60004
Private Employment Agency

Circle 136 on inquiry card.

SURPLUS EQUIPMENT

- **MINI TERMINAL \$320**
 - Full duplex, 20 ma.
 - 16 character A/N display.
 - Addressable indicators (4) and tones (2).
 - Keyswitch field, 9 position.
 - Power supplies (+12V, +5V, +250V).
 - I.D. card sensor.
 - Forced air cooling.
 - Above with UPC label reader option, \$499.
- **KEYBOARD/DISPLAY TERMINAL \$149**
 - 9" composite video input monitor.
 - 12 volt power supply.
 - Keyboard (A/N, control and function fields), encoding electronics, 20 ma.
- **16 CHARACTER A/N DISPLAY \$149**
- **UPC LABEL READER SYSTEM \$249**
- **9" MONITOR \$94**

SPECIAL SYSTEMS, INC.
 8045 Newell Street
 Silver Spring, Md. 20910
 (301) 587-3607

Circle 341 on inquiry card.

LIFETIME GUARANTEED QUARTZ CRYSTALS

1.000	5.000	11.1550
1.8432	5.0688	12.440
2.000	5.185	14.3182
2.0971	5.2428	15.000
2.4576	5.7143	17.2422
2.500	6.000	18.000
3.000	6.144	18.432
3.2768	6.5536	20.000
3.579	6.7584	22.1184
4.000	8.000	27.000
4.1943	8.1818	32.000
4.9152	10.000	36.000

ALL ABOVE MIX 1-9 4.50
 MIX 10+ 3.95

ADD 5% SHIPPING
 CAL RES. - ADD 8% SALES TAX

FREE OSCILLATOR SCHEMATICS WITH ANY ORDER

QUALITY COMPUTER PARTS
 P.O. BOX 743/CHATSWORTH, CA. 91311

Circle 323 on inquiry card.

\$231 Paper-Tape Reader Has One Moving Part

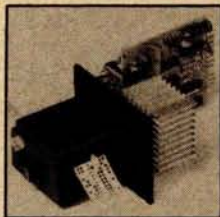

TTL interface, reads standard tape at 150 cps, asynchronous. Bi-directional, the unit stops on characters and automatically detects taut tape. Power requirements are +5V at 200 mA and 24V at 600 mA. Stand alone version with parallel or serial RS232 outputs, fanfold box and spooler also available. Price \$231 (100 units).

Addmaster Corporation
 416 Junipero Serra Drive
 San Gabriel CA 91776

Circle 10 on inquiry card.

8048 Family

A one board microcomputer utilizing the 8035 geared toward stand alone applications with:

- one 8-bit input port
- one 8-bit output port
- one 8-bit bidirectional port
- fully programmable hand shake lines on each port
- crystal based timer
- 64 bytes RAM, expandable to 1k bytes
- provisions for program memory to 4k bytes
- single supply capability [+5V]
- low cost [64.95 - singles]

Money order, Check, or C.O.D.
 Send orders to:

Adroit Electronics, Inc.
 5 East Long Street
 Suite 1012
 Columbus, Ohio 43215
 614-221-3060

Circle 5 on inquiry card.

AURORA, IL AREA FARNSWORTH COMPUTER CENTER

1891 N. Farnsworth Ave.
 Aurora, IL 60505
 (at the E-W Tollway)
 (312) 851-3888

- Apple
- Cromemco
- Texas Instrument

Now Featuring —

IDS-440 Printer
w/Graphics Software for Apple

Check our prices on Heath
 Pet, Atari, Imsai, Sorcerer

WEEKDAYS 12 to 8; SAT. 10 to 5

Sales — Service — Classes

Circle 135 on inquiry card.

C-10 SHORT CASSETTES 50 FT.



Qty. Price
 1 \$1.00
 10 \$0.75
 50 \$0.65

Premium tape and cassettes acclaimed by thousands of repeat order microcomputer users. Price includes labels, cassette box and shipping in U.S.A. VISA and M/C orders accepted. California residents add sales tax. Phone (408) 735-8832.

MICROSETTE CO.
 777 Palomar Avenue
 Sunnyvale, CA 94086

Circle 227 on inquiry card.

TEXAS INSTRUMENT COMP	
TI 99-4 COMPUTER	\$ 995.
TI 810 BASIC PRINTER	\$1590.
TI 820 BASIC PRINTER	\$1990.
TI SOFTWARE	\$5AVE
CENTRONICS PRINTERS	
779-2 TRAC. FD	\$949.
779-1 FRIC. FD	\$890.
730-1 NEW PRNTR	\$799.
730-3	\$849.
MICRO P1 \$390.	MICKO S1 \$475.
COMMODORE BUSINESS MACHINES	
PET 2001-BK	\$675.
PET 2001-16N,B	\$859.
PET 2001-32N,B	\$1090.
PET 2040 DUAL FLOPPY	\$1090.
PET 2022 TRAC.FD PRINTER	\$849.
PET 2023 FRIC.FD PRINTER	\$749.
NORTH STAR COMPUTERS	
BIG \$\$ SAVINGS	
INTERTEC SUPERBRAIN	
THE HONOR GRADUATE COMPUTER	\$2990
DISPLAY TERMINALS	
INTERTUBE II	\$725
HAZELTINE 1400	\$690.
1410	\$85.
1500	\$950.
1510	\$1149.

MULTI-BUSINESS COMPUTER SYSTEMS
 28 HARLBOROUGH STREET
 PORTLAND, CONN. 06480
 (203) 342-2747

Circle 277 on inquiry card.

Wire Wrap Tools



BATTERY HOBBY TOOL*

- Auto Indexing
- Anti-Overwrapping
- Modified Wrap

BW2628	Tool	\$19.85
BT30	#30 Bit	2.95
BT2628	#26 Bit	7.95
BC1	Batteries & Charger..	11.00

*Requires 2 "C" Niced Batteries

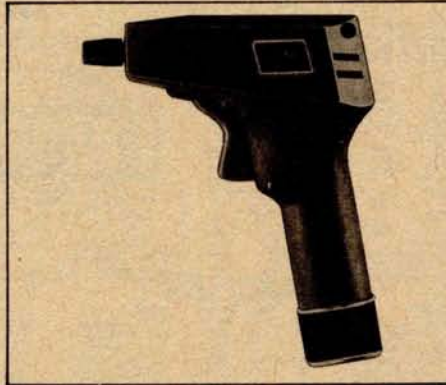

BATTERY INDUSTRIAL TOOL*

- Accepts Industrial Bits and Sleeves (Gardner Denver or equiv.)
- Industrial Motor for Production Wire-wrapping
- Backforce Avail. (Recommended for #30).

BW928	Tool	49.95
BW928BF	Backforce Model	52.95
Bit & Sleeve	Specify #22-#30	29.50
BC1	Batteries & Charger..	11.00

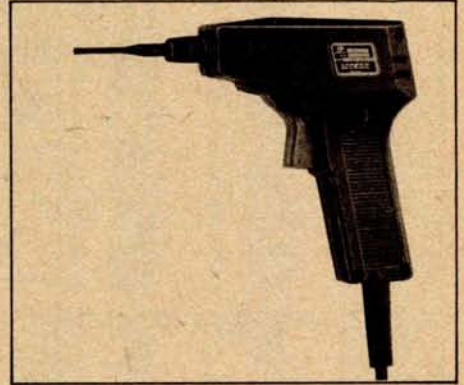

ELECTRIC INDUSTRIAL TOOL

- Accepts Industrial Bits and Sleeves (Gardner Denver or equiv.)
- Industrial Motor for Production Wire-wrapping
- Backforce Avail. (Recommended for #30).

EW8	Tool	85.00
EW28F	Backforce Model	92.90
Bit & Sleeve	#22 or #30.....	29.50

RN IC Sockets

RN HIGH RELIABILITY eliminates trouble. "Side-wipe" contacts make 100% greater surface contact with the wide, flat sides of your IC leads for positive electrical connection.

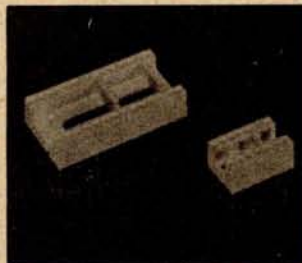

WIRE WRAP SOCKETS

	1-9	10-24	25-99	100-249	250-1K
8 Pin	40	.36	.34	.31	.27
14 Pin		.39	.37	.34	.32
16 Pin		.42	.40	.36	.34
18 Pin	.70	.60	.55	.50	.45
20 Pin	.90	.80	.75	.65	.62
22 Pin	.95	.85	.80	.70	.65
24 Pin	.95	.85	.80	.70	.65
25 Pin st.	1.25	1.15	1.00	.95	.90
28 Pin	1.25	1.15	1.00	.95	.90
40 Pin	1.65	1.45	1.35	1.20	1.10

SOLDER TAIL

	1-9	10-24	25-99	100-249	250-1K
Low Profile Tin					
8 Pin	.21	.18	.16	.15	.14
14 Pin	—	.19	.17	.15	.13
16 Pin	—	.21	.19	.17	.15
18 Pin	.30	.28	.27	.26	.25
20 Pin	.35	.34	.33	.32	.31
22 Pin	.36	.34	.30	.27	.26
24 Pin	.38	.36	.32	.29	.28
28 Pin	.45	.44	.43	.40	.39
40 Pin	.63	.62	.61	.58	.57

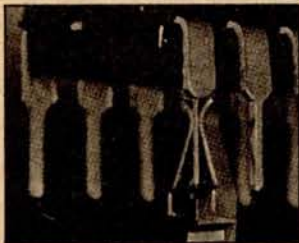

OK PRODUCTS

WD 30	50 ft. Wire Dispenser, Red, White, Blue or Yellow	\$3.75
WD-30-TRI	TRI Color Dispenser	5.50
R-30-TRI	Refill for TRI Color	3.75
INS 1416	14 & 16 pin Insertion Tool	3.25
MOS 40	40 pin Insertion Tool	7.50
EX-1	IC Extractor Tool	1.49
H-PCB-1	Hobby PC Board	4.99
WSU 30	Hand Wrap/Unwrap/Strip Tool	6.25
WSU 30M	Same as WSU 30 with Modified Wrap	7.50

ORDERING INFORMATION

- Orders under \$25, add \$2 handling
- Blue Label or First Class, add \$1 (up to 3 lbs.)
- CODs, VISA & MC orders will be charged shipping
- Most orders shipped next day.

7400 TTL

SN7400N	16	SN7400N	29	SN74160N	89
SN7401N	18	SN7401N	35	SN74161N	89
SN7402N	18	SN7402N	49	SN74162N	1.95
SN7403N	18	SN7403N	59	SN74163N	89
SN7404N	18	SN7404N	5.00	SN74164N	89
SN7405N	20	SN7405N	50	SN74165N	89
SN7406N	29	SN7406N	99	SN74166N	1.25
SN7407N	29	SN7407N	59	SN74167N	1.95
SN7408N	29	SN7408N	79	SN74170N	1.50
SN7409N	20	SN7409N	35	SN74171N	1.50
SN7410N	18	SN7410N	1.75	SN74172N	1.25
SN7411N	25	SN7410N	45	SN74174N	89
SN7412N	25	SN7411N	59	SN74175N	79
SN7413N	40	SN7412N	43	SN74176N	79
SN7414N	70	SN7412N	43	SN74177N	79
SN7416N	25	SN7416N	65	SN74179N	1.95
SN7417N	25	SN7416N	85	SN74180N	79
SN7420N	20	SN7416N	65	SN74181N	1.95
SN7421N	29	SN7416N	3.00	SN74182N	79
SN7422N	39	SN7416N	89	SN74184N	1.95
SN7423N	35	SN7416N	35	SN74185N	1.95
SN7425N	29	SN7416N	59	SN74186N	9.95
SN7426N	29	SN7416N	1.95	SN74187N	9.95
SN7427N	35	SN7416N	1.25	SN74188N	1.25
SN7429N	39	SN7416N	1.25	SN74189N	1.25
SN7430N	39	SN7416N	49	SN74192N	79
SN7432N	25	SN7416N	49	SN74193N	79
SN7433N	25	SN7416N	49	SN74194N	79
SN7434N	25	SN7416N	49	SN74195N	79
SN7435N	25	SN7416N	49	SN74196N	79
SN7436N	25	SN7416N	49	SN74197N	79
SN7437N	25	SN7416N	49	SN74198N	79
SN7438N	25	SN7416N	49	SN74199N	79
SN7439N	20	SN7416N	75	SN74200N	79
SN7440N	20	SN7416N	75	SN74201N	79
SN7441N	83	SN7416N	2.50	SN74202N	79
SN7442N	49	SN7416N	2.95	SN74203N	79
SN7443N	75	SN7416N	2.95	SN74204N	79
SN7444N	75	SN7416N	2.95	SN74205N	79
SN7445N	75	SN7416N	2.95	SN74206N	79
SN7446N	69	SN7416N	1.95	SN74207N	79
SN7447N	59	SN7416N	1.95	SN74208N	79
SN7448N	59	SN7416N	1.95	SN74209N	79
SN7449N	59	SN7416N	1.95	SN74210N	79
SN7450N	20	SN7416N	59	SN74211N	79
SN7451N	20	SN7416N	59	SN74212N	79
SN7452N	20	SN7416N	59	SN74213N	79
SN7453N	20	SN7416N	59	SN74214N	79
SN7454N	20	SN7416N	59	SN74215N	79
SN7455N	20	SN7416N	59	SN74216N	79
SN7456N	20	SN7416N	59	SN74217N	79
SN7457N	20	SN7416N	59	SN74218N	79
SN7458N	20	SN7416N	59	SN74219N	79
SN7459N	20	SN7416N	59	SN74220N	79
SN7460N	20	SN7416N	59	SN74221N	79

EXCITING NEW KITS

Digital Thermometer Kit

JE600 HEXADECIMAL ENCODER KIT

FEATURES:

- Full 8 bit latched output for micro-processor use
- 3 User Define keys with one being bi-stable
- On-board keypad provided for all 19 keys
- LED readout to verify entries
- Easy interfacing with standard 16 pin D-sub connector
- Only +5VDC required for operation

Full 8 BIT LATCHED OUTPUT—19 KEYBOARD

The JE600 Encoder Keyboard provides two separate hexadecimal digits produced from sequential key entries to allow direct programming for 8 bit microprocessor or 8 bit memory circuits. Three (3) additional keys are provided for user operations with one having a bistable output available. The outputs are latched and monitored with LED readouts. Also included is a key entry strobe.

JE600 \$59.95
Hexadecimal Keypad only \$14.95

JE300 \$39.95

TELEPHONE/KEYBOARD CHIPS

AY-5-9100	Push Button Telephone Dialer	\$14.95
AY-5-9200	Rotary Dialer	14.95
AY-5-9500	CMOS Clock Generator	4.95
AY-5-2376	Keyboard Encoder (88 keys)	14.95
H00165	Keyboard Encoder (16 keys)	7.95
74C92Z	Keyboard Encoder (16 keys)	5.95

ICM CHIPS

ICM7045	CMOS Precision Timer	24.95
ICM7205	CMOS LED Stopwatch/Timer	19.95
ICM7207	Oscillator Controller	7.50
ICM7208	Seven Decade Counter	19.95
ICM7209	Clock Generator	6.95

NMOS READ ONLY MEMORIES

MCM65571	128 X 9 X 7 ASCII Shifted with Greek	13.50
MCM65574	128 X 9 X 7 Math Symbol & Pictures	13.50
MCM65574	128 X 9 X 7 Alphabetical Control	13.50

DISCRETE LEADS

XC556R	200' dia.	5/81	XC209R	125' dia.	5/81
XC556G	green	4/81	XC209G	green	4/81
XC556Y	yellow	4/81	XC209Y	yellow	4/81
XC556C	clear	4/81	XC209C	clear	4/81

200' dia.

XC22R	200' dia.	5/81	XC262R	185' dia.	5/81
XC22G	green	4/81	XC262G	green	4/81
XC22Y	yellow	4/81	XC262Y	yellow	4/81
XC22C	clear	4/81	XC262C	clear	4/81

170' dia.

MV10B	170' dia.	4/81	XC111R	190' dia.	5/81
MV50	190' dia.	6/81	XC111G	green	4/81
			XC111Y	yellow	4/81
			XC111C	clear	4/81

.085' dia.

INFRA-RED LED
1/4"x1/4"x1/16" flat
5/81

TIMEX T1001 LIQUID CRYSTAL DISPLAY CLASS II
FIELD EFFECT
4 DIGIT - 5" CHARACTERS
THREE UNICODERS
2.00" X 1.20" PACKAGE
INCLUDES CONNECTOR
T1001-Transmissive \$7.95
T1001A-Reflective \$2.25

MISCELLANEOUS

TL074CN	Quad Low Noise Bi-let Op Amp	2.49
TL494CN	Switching Regulator	4.49
TL496CP	Single Switching Regulator	1.75
11C90	Divide 10/11 Prescaler	19.95
9H99	Hi-Speed Divide 10/11 Prescaler	11.95
4N33	Photo-Darlington Opto-isolator	4.95
4N35	Top Octave Freq. Generator	17.50
MKS0240	5MHz 2-phase MOS clock driver	3.75
DS0026CH	27' read num. display w/integ. logic chip	10.50
TL338	TV Camera Sync. Generator	14.95
MMS3320	4 1/2 Digit DPM Logic (Special)	3.95
MMS3330	3 1/2 Digit A/D Converter Set	25.00/set

DISPLAY LEADS

TYPE	POLARITY	HT	PRICE	TYPE	POLARITY	HT	PRICE
MAN 1	Common Anode-red	270	2.95	MAN 6730	Common Anode-red ± 1	560	99
MAN 2	5 x 7 Dot Matrix-red	300	4.95	MAN 6740	Common Cathode-red-D.D.	560	99
MAN 3	Common Cathode-red	125	25	MAN 6750	Common Cathode-red ± 1	560	99
MAN 4	Common Cathode-red	187	1.95	MAN 6760	Common Cathode-red	560	99
MAN 7G	Common Anode-green	300	1.25	MAN 6780	Common Cathode-red	560	99
MAN 7Y	Common Anode-yellow	300	99	DL701	Common Anode-red ± 1	300	99
MAN 7Z	Common Anode-red	125	25	DL704	Common Cathode-red	300	99
MAN 74	Common Cathode-red	300	1.25	DL707	Common Anode-red	300	99
MAN 82	Common Anode-yellow	300	99	DL728	Common Cathode-red	500	1.49
MAN 84	Common Cathode-yellow	300	99	DL741	Common Anode-red	600	1.25
MAN 3620	Common Anode-orange	300	99	DL745	Common Anode-red ± 1	630	1.49
MAN 3630	Common Cathode-orange	300	99	DL747	Common Cathode-red	600	1.49
MAN 3640	Common Cathode-orange	300	99	DL749	Common Cathode-red ± 1	630	1.49
MAN 4610	Common Anode-orange	300	99	DL750	Common Cathode-red	600	1.49
MAN 4620	Common Cathode-orange	300	99	DL758	Common Cathode-red	110	35
MAN 4630	Common Anode-orange	300	99	DL759	Common Cathode-red	250	69
MAN 4740	Common Cathode-red	400	99	FD358	Common Cathode ± 1	357	99
MAN 4810	Common Anode-yellow	400	99	FD359	Common Cathode	357	75
MAN 4840	Common Anode-red	400	99	FD503	Common Cathode(FD500)	500	99
MAN 4850	Common Anode-red	400	99	FD507	Common Anode (FD501)	500	99
MAN 6610	Common Anode-orange-D.D.	560	99	5082-7302	4 x 7 Digit. Digi-LHDP	600	19.95
MAN 6630	Common Anode-orange ± 1	560	99	5082-7304	Overrange character (±1)	600	15.00
MAN 6640	Common Cathode-orange-D.D.	560	99	H0SP-3400	Common Anode-red	800	2.10
MAN 6650	Common Cathode-orange	560	99	H0SP-3403	Common Cathode-red	800	2.10
MAN 6660	Common Cathode-orange	560	99	5082-7304	4 x 7 Digit. Digi-HPDP	600	19.95
MAN 6710	Common Anode-red-D.D.	560	99	5082-7302	4 x 7 Digit. Digi-LHDP	600	19.95

LITRONIX ISO-LIT 1

Photo Transistor Opto-isolator
(Same as M97 2 or 4N23)

2/99¢

EXAR

XR205	\$8.40	XR224CP	1.50
XR210	3.40	XR225A	4.25
XR215	4.40	XR2556	3.20
XR220	1.55	XR2567	2.99
XR-LS55	1.50	XR2567	1.25
XR555	39	XR1800	3.20
XR556	99	XR1800	4.00
XR567CP	99	XR2207	3.85
XR567CT	1.25	XR2208	5.20
XR1310P	99	XR2209	1.75
XR1463N	3.85	XR2211	3.85
XR1468	1.39	XR2212	4.35
XR1489	1.39	XR2212	4.35
		XR4741	1.47

RCA LINEAR

CA3013T	2.15	CA3082N	2.00
CA3023T	2.46	CA3083N	1.60
CA3035T	2.48	CA3086N	8.95
CA3038T	1.35	CA3089N	3.75
CA3046N	1.30	CA3130T	1.29
CA3059N	3.25	CA3140T	1.25
CA3060N	3.25	CA3160T	1.25
CA3080T	85	CA3401N	49
CA3081N	2.00	CA3800N	3.50

CALCULATOR CHIPS/DRIVERS

MM5278	82.95
MM5278	2.95
MM5311	4.95
MM5312	4.95
MM5313	4.95
MM5314	4.95
MM5315	4.95
MM5316	4.95
MM5317	4.95
MM5318	4.95
MM5319	4.95
MM5320	4.95
MM5321	4.95
MM5322	4.95
MM5323	4.95
MM5324	4.95
MM5325	4.95
MM5326	4.95
MM5327	4.95
MM5328	4.95
MM5329	4.95
MM5330	4.95
MM5331	4.95
MM5332	4.95
MM5333	4.95
MM5334	4.95
MM5335	4.95
MM5336	4.95
MM5337	4.95
MM5338	4.95
MM5339	4.95
MM5340	4.95
MM5341	4.95
MM5342	4.95
MM5343	4.95
MM5344	4.95
MM5345	4.95
MM5346	4.95
MM5347	4.95
MM5348	4.95
MM5349	4.95
MM5350	4.95

CLOCK CHIPS

MM5309	\$4.95
MM5310	\$4.95
MM5311	\$4.95
MM5312	\$4.95
MM5313	\$4.95
MM5314	\$4.95
MM5315	\$4.95
MM5316	\$4.95
MM5317	\$4.95
MM5318	\$4.95
MM5319	\$4.95
MM5320	\$4.95
MM5321	\$4.95
MM5322	\$4.95
MM5323	\$4.95
MM5324	\$4.95
MM5325	\$4.95
MM5326	\$4.95
MM5327	\$4.95
MM5328	\$4.95
MM5329	\$4.95
MM5330	\$4.95
MM5331	\$4.95
MM5332	\$4.95
MM5333	\$4.95
MM5334	\$4.95
MM5335	\$4.95
MM5336	\$4.95
MM5337	\$4.95
MM5338	\$4.95
MM5339	\$4.95
MM5340	\$4.95

MOTOROLA

MC1408L	\$4.95
MC1408L	\$5.75
MC1408L	\$2.95
MC3022P	2.95
MC3061P	1.00
MC4016(74411)	7.50
MC4024P	3.00
MC4040P	6.95
MC4044P	6.95
MC4044P	4.50

IC SOLDERTAIL - LOW PROFILE (TIN) SOCKETS

8 pin LP	\$17	16 pin LP	\$37
14 pin LP	\$19	18 pin LP	\$38
16 pin LP	\$21	20 pin LP	\$45
18 pin LP	\$22	24 pin LP	\$58
20 pin LP	\$24	30 pin LP	\$63
14 pin ST	\$27	24 pin ST	\$99
16 pin ST	\$29	36 pin ST	\$139
18 pin ST	\$35	40 pin ST	\$159
24 pin ST	\$49		

SOLDERTAIL STANDARD (TIN)

8 pin SG	\$30	27	24
14 pin SG	\$35	32	29
16 pin SG	\$38	35	32
18 pin SG	\$42	42	43

SOLDERTAIL STANDARD (GOLD)

8 pin SG	\$30	27	24
14 pin SG	\$35	32	29
16 pin SG	\$38	35	32
18 pin SG	\$42	42	43

WIRE WRAP SOCKETS (GOLD) LEVEL #3

8 pin WW	\$39	36	31
10 pin WW	\$45	41	37
14 pin WW	\$39	38	37
16 pin WW	\$43	42	41
18 pin WW	\$47	46	45

DIODES

TYPE	VOLTS	W	PRICE	TYPE	VOLTS	W	PRICE
1N746	3.3	400m	4/10	1N4003	100	1V 1 AMP	12/10
1N751	5.1	400m	4/10	1N4004	200	1V 1 AMP	12/10
1N752	5.6	400m	4/10	1N4005	300</		

Transistor Checker



**— Completely Assembled —
— Battery Operated —**
The ASI Transistor Checker is capable of checking a wide range of transistor types, either "in circuit" or out of circuit. To operate, simply plug the transistor to be checked into the front panel socket, or connect it with the alligator clip test leads provided. The unit safely and automatically identifies low, medium and high-power PNP and NPN transistors. Size: 3 1/4" x 6 1/4" x 2". "C" cell battery not included.

Trans-Check \$19.95 ea.

Custom Cables & Jumpers



DB 25 Series Cables

Part No.	Cable Length	Connectors	Price
DB25P-4-P	4 Ft.	2-DP25P	\$15.95 ea.
DB25P-4-S	4 Ft.	1-DP25P/1-25S	\$16.95 ea.
DB25S-4-S	4 Ft.	2-DP25S	\$17.95 ea.

Dip Jumpers

Part No.	Length	Pin Configuration	Price
DJ14-1	1 ft.	1-14 Pin	\$1.59 ea.
DJ16-1	1 ft.	1-16 Pin	1.79 ea.
DJ24-1	1 ft.	1-24 Pin	2.79 ea.
DJ14-1-14	1 ft.	2-14 Pin	2.79 ea.
DJ16-1-16	1 ft.	2-16 Pin	3.19 ea.
DJ24-1-24	1 ft.	2-24 Pin	4.95 ea.

For Custom Cables & Jumpers, See JAMECO 1979 Catalog for Pricing

CONNECTORS

25 Pin-D Subminiature

DB25P (as pictured)	PLUG (Meets RS232)	\$2.95
DB25S	SOCKET (Meets RS232)	\$3.50
DB51226-1	Cable Cover for DB25P or DB25S	\$1.75

PRINTED CIRCUIT EDGE-CARD

156 Spacing-Tw. Double Row-Out — Buried Contacts — Fits 054 to 070 P.C. Cards

15/30	PINS (Solder Eyelet)	\$1.95
18/36	PINS (Solder Eyelet)	\$2.49
22/44	PINS (Solder Eyelet)	\$2.95
50/100 (100 Spacing)	PINS (Wire Wrap)	\$6.95
50/100 (125 Spacing)	PINS (Wire Wrap)	R881-1 \$6.95

4-Digit Clock Kit

- Bright .357" ht. red display
- Sequential flashing colon
- 12 or 24 hour operation
- Estrutted aluminum case (black)
- Pressure switches for hours, minutes & hold functions
- Includes all components, case and wall transformer
- Size: 3 1/4" x 1 1/4" x 1 1/4"

JE730 \$14.95

Jumbo 6-Digit Clock Kit

- Four .630" ht. and two .300" ht. common anode displays
- Uses MM5314 clock chip
- Switches for hours, minutes and hold functions
- Hours easily viewable to 30 feet
- Simulated walnut case
- 115 VAC operation
- 12 or 24 hour operation
- Includes all components, case and wall transformer
- Size: 6 1/4" x 3 1/4" x 1 1/4"

JE747 \$29.95

JE701

- Bright .300 ht. comm. cathode display
- Uses MM5314 clock chip
- Switches for hours, minutes and hold modes
- Hrs. easily viewable to 20 ft.
- Simulated walnut case
- 115 VAC operation
- 12 or 24 hr. operation
- Incl. all components, case & wall transformer
- Size: 6 1/4" x 3-1/8" x 1 1/4"

6-Digit Clock Kit \$19.95

REMOTE CONTROL TRANSMITTER & RECEIVER

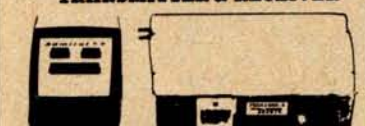

• CAN BE USED AS REMOTE CONTROL FOR TV
• USES 115 VOLT 200 MA. COMMON OPERA.
• TRANSMITTER OPERATES ON 40.0 MHz.
• RECEIVER OPERATES ON 40.0 MHz. CHANNEL
• TRANSMITTER OPERATES ON 40.0 MHz. CHANNEL
• TRANSMITTER OPERATES ON 40.0 MHz. CHANNEL
• TRANSMITTER OPERATES ON 40.0 MHz. CHANNEL
• TRANSMITTER OPERATES ON 40.0 MHz. CHANNEL

\$19.95

Digital Stopwatch Kit

- Use Intersil 7206 Chip
- Plated thru double-sided P.C. Board
- LED display (red)
- Times to 99.99 sec. with auto reset
- Quartz crystal controlled
- Three stopwatches in one: single event, split (cumulative) & Taylor (sequential timing)
- Uses 3 penlite batteries
- Size: 4.5" x 2.15" x .90"

JE900 \$39.95

MICROPROCESSOR COMPONENTS

8080A/8085A SUPPORT DEVICES		MICROPROCESSOR MANUALS	
8080A CPU	\$ 9.95	M-200 User Manual	\$7.50
8212 8-Bit Input/Output	3.25	M-CDP1802 User Manual	7.50
8214 Priority Interrupt Control	5.95	M-2050 User Manual	5.00
8216 Bi-Directional Bus Driver	3.49		
8224 Clock Generator/Driver	3.95		
8226 Bus Driver	3.49		
8228 System Controller/Bus Driver	5.95		
8238 System Controller	5.95		
8251 Prog. Comm. 1/0 (USART)	7.95		
8253 Prog. Interval Timer	14.95		
8255 Prog. Periph. 1/0 (PPP)	9.95		
8257 Prog. DMA Control	19.25		
8259 Prog. Interrupt Control	18.95		
4860/6800 SUPPORT DEVICES		MICROPROCESSOR MANUALS	
MC6800 MPU	\$14.95		
MC6802CPU MPU with Clock and Ram	24.95		
MC68010API 128K Static RAM	5.95		
MC6821 Periph. Inter. Adapt (MC6820)	7.49		
MC6828 Priority Interrupt Controller	12.95		
MC6830L8 1024X8 Bit ROM (MC68A30-8)	14.95		
MC6850 Asynchronous Comm. Adapter	7.95		
MC6882 Synchronous Serial Data Adapt.	9.95		
MC6890 0-600 bps Digital MODEM	12.95		
MC6882 2400 bps Modulator	14.95		
MC6888 Quad 3-State Bus Trans. (MC68726)	2.25		
MICROPROCESSOR CHIPS — MISCELLANEOUS		MICROPROCESSOR MANUALS	
Z80/780C CPU	\$19.95		
Z80A/780-1 CPU	24.95		
CDP1802 CPU	19.95		
2650 MPU	19.95		
6501 CPU	11.95		
8035 8-Bit MPU w/clock, RAM, 1/0 lines	19.95		
P8085 CPU	19.95		
TMS9900UL 16-Bit MPU w/hardware, multiply & divide	49.95		
SHIFT REGISTERS		MICROPROCESSOR MANUALS	
MM5200H Dual 25 Bit Dynamic	5.50		
MM5203H Dual 50 Bit Dynamic	5.50		
MM5204H Dual 16 Bit Static	.50		
MM5209H Dual 100 Bit Static	1.50		
MM5210H Dual 64 Bit Accumulator	.89		
MM5210H 500/512 Bit Dynamic	.89		
2504T 1024 Dynamic	3.95		
2518 Hex 32 Bit Static	4.25		
2522 Dual 132 Bit Static	2.95		
2524 512 Static	.99		
2525 1024 Dynamic	2.95		
2527 Dual 256 Bit Static	3.95		
2528 Dual 250 Static	4.00		
2529 Dual 240 Bit Static	4.00		
2532 Quad 80 Bit Static	2.95		
2533 1024 Static	2.95		
3341 File Register File (170State)	2.49		
74LS670 4X4 Register File (170State)	2.49		
A-Y-S-1013 30K BAUD UART'S	5.95		
		1103 1024X1 Static	3.95
		2101(8101) 256X4 Static	3.95
		2102 1024X1 Static	1.75
		2111(8111) 256X4 Static	3.95
		2112 256X4 Static MOS	4.95
		2114 1024X4 Static 450ns	9.95
		2144 1024X4 Static 450ns low power	10.95
		2144-3 1024X4 Static 300ns	10.95
		2144-3 1024X4 Static 300ns low power	11.95
		2584X1 256X4 Static	7.95
		5280/2107 4096X1 Dynamic	4.95
		7489 16X8 Static	1.75
		745200 256X1 Static Tristate	4.95
		82421 256X1 Static	3.95
		UPD414 4K Dynamic 16 pin	4.95
		(MK4027) 16K Dynamic 16 pin	9.95
		16K Dynamic 16 pin	9.95
		(MK4116) 8K Static	14.95
		45N1 45N1 Static	14.95
		TMS4045 1024X4 Static	14.95
		2117 16,384X1 Dynamic 350ns	9.95
		MMS262 20X1 Dynamic	4/1.00
		1702A 2048 FAMOS	\$5.95
		271602T 16K* EPROM	\$9.95
		TMS2516 16K* EPROM	49.95
		(2716) Requires single +3V power supply	
		48X8 EPROM	\$9.95
		TMS2332 8K EPROM	10.95
		2708 8K EPROM	29.95
		2716 T.J. 16K* EPROM	29.95
		Requires 3 voltages, —5V, +5V, +12V	
		5203 256X8 FAMOS	14.95
		6301-17611 1024 Tristate Bipolar	3.49
		6330-17602 256 Open C Bipolar	2.95
		82S23 32X8 Open Collector	3.95
		82S115 4096 Bipolar	19.95
		82S123 32X8 Tristate	3.95
		74188 256 TTL Open Collector	9.95
		74188 256 TTL Open Collector	3.95
		74S287 1024 Static	2.95

CONTINENTAL SPECIALTIES

Proto Board 203



A total ready-to-use power breadboard prototyping device with a built-in regulated, short-circuit protected power supply. Just plug in and start building! 2 extra power supply leads provided for external operation. Self-contained with power switch, indicator lamp and power fuse. 26 1/4 pin DIP sockets. An attractive two-tone quality case. All metal construction. 8 1/2" L x 6" W x 2 1/4" H.

PB 203 \$75.00

Proto Board 203A



All the features of the PB 203 plus additional power supply flexibility, provided by the Regulated 5VDC supply (same specifications as PB 203). Freely used separate +15VDC and —15VDC 3.0A sources, each with internally and independently adjustable output voltage. Rigi-flex and torx screw terminals. 100VAC at 0.25A.

PB 203A \$124.95

62-Key ASCII Encoder Keyboard Kit



The JE610 62-Key ASCII Encoder Keyboard Kit can be interfaced into most any computer system. The JE610 Kit comes complete with an industrial grade keyboard switch assembly (62 keys), IC's, sockets, connector, electronic components and a double-sided printed wiring board. The keyboard assembly requires +5V @ 150mA and —12V @ 10mA for operation.

JE610 \$79.95

REGULATED POWER SUPPLY

JE200 5V-1 AMP POWER SUPPLY

- Uses LM309K
- Heat sink provided
- PC Board construction
- Provides a solid 1 amp @ 5 volts
- Can supply up to ±5V, ±9V and ±12V with JE205 Adapter
- Includes components, hardware & instructions
- Size: 3 1/2" x 5" x 2 1/4"

JE200 \$14.95

JE205 ADAPTER BOARD

- Adapts to JE200 — ±5V, ±9V and ±12V
- DC/DC converter w/ +5V input
- Toroidal hi-speed switching XMF
- Short circ. protection
- PC Board construction
- Piggy-back to JE200 board
- Size: 3 1/2" x 2" x 9/16" h

JE205 \$12.95

\$10.00 Min. Order — U.S. Funds Only Spec Sheets — 25¢
Calif. Residents Add 6% Sales Tax 1979 Catalog Available — Send 41¢ stamp
Postage — Add 5¢ plus \$1 Insurance (if desired)



Jameco ELECTRONICS
MAIL ORDER ELECTRONICS — WORLDWIDE
1021 HOWARD AVENUE, SAN CARLOS, CA 94070
ADVERTISED PRICES GOOD THRU OCTOBER

The Incredible "Pennywhistle 103"



\$139.95 Kit Only

The Pennywhistle 103 is capable of recording data to and from audio tape without critical speed requirements for the recorder and it is able to communicate directly with another modern and terminal for telephone "hamming" and communications. In addition, it is free of critical adjustments and is built with non-precision, readily available parts.

Data Transmission Method Frequency Shift Keying, full-duplex (half-duplex selectable).

Maximum Data Rate 300 Baud

Data Format Asynchronous Serial (return to mark level required between each character).

Receive Channel Frequencies 2025 Hz for space, 2225 Hz for mark, 1270 mark, High = 025 space, 2225 mark.

Transmit Channel Frequencies Switch selectable, Low (normal) = 1070 space, 1270 mark, High = 025 space, 2225 mark.

Receive Sensitivity —45 dbm acoustically coupled.

Transmit Level —15 dbm nominal, Adjustable from —6 dbm to —20 dbm.

Receive Frequency Tolerance Frequency reference automatically adjusts to allow for operation between 1800 Hz and 2400 Hz.

Digital Data Interface EIA RS-232C or 20 mA current loop (receiver is potentiometer and non-polar).

Power Requirements 120 VAC, single phase, 10 Watts.

Physical All components mounted on a single 5" by 9" printed circuit board. All components included, is potentiometer and non-polar.

Requires a VOM, Audio Oscillator, Frequency Counter and/or Oscilloscope to align.

TRS-80

16K Conversion Kit

Expand your 4K TRS-80 System to 16K. Kit comes complete with:

- 8 each UPD416-1 (16K Dynamic Rams) 250NS
- Documentation for conversion

TRS-16K \$75.00

COMPUTER CASSETTES

- 6 EACH 15 MINUTE HIGH QUALITY C-15 CASSETTES
- PLASTIC CASE INCLUDED
- 12 CASSETTE CAPACITY
- ADDITIONAL CASSETTES AVAILABLE #C-15-\$2.95 ea

CAS-6

\$14.95
(Case and 6 Cassettes)

SUP 'R' MOD II

UHF Channel 33 TV Interface Unit Kit

Wide Band B/W or Color System

- Converts TV to Video Display for home computers, CCTV camera, Apple II, works with Cromeco Dazzer, SOL-20, IRS-80, Challenger, etc.
- MOD II is retuned to Channel 33 (UHF).
- Includes coaxial cable and antenna transformer.

MOD II \$29.95 Kit

Function Generator Kit

- Provides 3 basic waveforms: sine, triangle & square wave
- Frequency range from 1 Hz to 100K Hz
- Output amplitude from 0-volts to over 6 volts (peak to peak)
- Uses a 12V supply or a ±6V split supply
- Incl. chip, P.C. board, components and instructions.

JE2206B \$19.95

IDEAL FOR TRS 80 CASSETTE CONTROLLER

"Plug/Jack interface to any computer system requiring remote control of cassette functions"

The CC-100 controls cassette motor functions, monitors tape location with its internal speaker and requires no power. Eliminates the plugging and unplugging of cables during computer loading operation from cassette.

#CC-100 \$29.50

new Micro-Miniature Joystick



- 2 each 100K pots (Linear Taper)
- Printed Circuit Board Mount
- Size: 1" x 1-3/16" x 1-3/16"

Micro-Miniature Joystick . . . \$4.95

SOFTWARE FOR

APPLE II

All programs on high quality cassette tape, ready for use on any Apple II System with Applesoft Liberal use of prompting allows easy use even for the novice.

MATRIX MANIPULATION: Computes inversion, determinate, and solution of linearly independent simultaneous equations. Also performs matrix multiplication, division, addition & subtraction: 8K - \$17.50

TRIANGLE SOLUTIONS: Computes unknown quantities (including area) for any triangle. Also computes area of any polygon: 8K-\$15.00

INVESTMENT & MORTGAGE MANAGEMENT: Just the program for the homeowner, small investor or business executive faced with difficult financial decisions. Computes amortization schedule, present or future values of a series of cash flows, days between dates, plus more: 8K - \$17.50

COMPUTER CAJUN CUISINE: Program computes exact amounts of all ingredients necessary for any number of servings for eight Louisiana soup and gumbo recipes: 16K - \$25.00

Send check or money order to:

TECHNICAL SOFTWARE INC.

P.O. Box 73043

Metairie, Louisiana 70033

Circle 365 on inquiry card.

Moonshadow Text Formatter for UCSD Pascal Systems

The UCSD Pascal system contains a screen-oriented text editor which is convenient, but which is not suited to word processing. It cannot underline, paginate automatically, or perform other essential text-processing functions. The **Moonshadow Text Formatter (MTF)** for Merrimack Systems solves this problem.

With the Moonshadow Text Formatter, documents produced with the screen editor are post-processed to provide these missing functions. It takes standard Pascal text files, operates on them, and sends fully formatted text output to the console display, a printer, or a disk file.

Moonshadow Text Formatter provides, in addition to a full range of formatting functions, advanced features including the combination of files into one document, variables in text (for form letters), and output character translation.

The Moonshadow Text Formatter is written in UCSD Pascal. It works on systems using either North Star 5-inch floppy disks or IBM-format 8-inch floppy disks.

All this for \$99.00 from

Merrimack Systems

POB 5218

Redwood City, CA 94063

(415) 365-6281

California residents should include 6% sales tax.

Also available: a SOL-VDM driver that makes a SOL appear to the Pascal system like a SOROC with random cursor, for \$25.00

Circle 216 on inquiry card.

PROGRAM YOUR CAREER

Join one of the fastest growing micro/mini systems manufacturers in the U.S. where your advancement is limited only by your talent and ability. Our client needs several software engineers (assembly) to contribute to the development of state-of-the-art products in such areas as diagnostics, graphics, networks, compiler and OS design, and systems software. Positions available at the intermediate and senior level. Starting salary is 18-30K. Please contact Dave Adams (617) 246-2815. Collect calls accepted. N.E. Recruiters, 6 Lakeside Office Park, Wakefield, MA 01880.

All fees and expenses paid by the company.

Circle 289 on inquiry card.

MASSACHUSETTS INSTITUTE OF TECHNOLOGY

Assistant Professor of Media Technology

A new position is being opened, beginning with a three-year appointment as Assistant Professor. Applicants must have strong backgrounds in computer graphics, image processing, and broadcast technology. The position is purposely created to merge these previously distinct disciplines. Candidates are expected to show experience and proficiency in all three fields.

The job includes teaching one subject per semester and developing a research program that can grow to support graduate students. One subject should be an undergraduate survey and laboratory, the other an advanced graduate subject reflecting state of the art techniques in computers and television. Both will be designed in concern with particular interests and experience of an applicant. Candidates should include a statement about their thoughts on such curriculum developments.

The position is 50% research, again driven by a candidate's own intellectual motivations. Statements about such interests will be helpful in reviewing applications.

Applications should be addressed to Professor Leon Groisser, Acting Head, Department of Architecture, MIT, Cambridge, MA 02139 by October 31, 1979. The appointment to be awarded at the earliest convenience of the most qualified candidate.

MIT IS AN EQUAL OPPORTUNITY/AFFIRMATIVE ACTION EMPLOYER

Circle 208 on inquiry card.

H8 OWNERS!

Want to do useful things with your H8? Frustrated with lack of support for the H8? Drop me a line or call (evenings-not Friday) and I'll send you an abstract of the prepared articles I presently have available such as 32 channel controller, Software clock, Selectric interface, Telephone circuits, Sound generator, 64K memory card . . .

Henry Fale

2918 S 7th St

Sheboygan WI 53081

(414) 452-4172

Circle 132 on inquiry card.

MAXIMUM VALUE FOR YOUR DOLLAR

NORTH STAR COMPUTER PRODUCTS

DOUBLE DENSITY	KIT	ASM
HRZ-1-32K-D	\$1590.	\$1850.
HRZ-2-32K-D	1910.	2200.
MDS-A-D	550.	640.
EXTRA DRIVE	330.	
QUAD DENSITY	KIT	ASM
HRZ-1-32K-Q	\$1750.	\$2040.
HRZ-2-32K-Q	2230.	2560.
MDS-A-Q	720.	800.
EXTRA DRIVE	480.	

All HORIZONS now come standard with 3 ports and all edge connectors and minimum 32K memory.

BOARDS-DISCS

	KIT	ASM
RAM-16K W/PARITY	\$300.	\$345.
RAM-32K W/PARITY	475.	520.
FPB-A	205.	270.

VERBATIM DISCS, BOX OF 10 . . . \$29. PP

We will try to beat any deal. Call:

A.E.I.

3851 HACKETT AVE.

LONG BEACH, CALIF. 90808

(213) 421-4815

Circle 21 on inquiry card.

CROMEMCO SYSTEMS DISCOUNTED

System 2 with 64k RAM—\$3195

System 3 with 32k RAM—\$4795

with 64k RAM—add \$ 595

Discounts up to 20% on most Cromemco hardware. We carry the full Cromemco line.

TORREY PINES BUSINESS SYSTEMS

14260 Garden Rd., Suite 8A

Poway Space Center

Poway, California 92064

Add 3% for shipping and handling
California residents add 6% sales tax

Circle 375 on inquiry card.

CASSETTE DUPLICATION

TRS-80 (I & II), PET, APPLE, KIM, ATARI

Quality software duplication is more than copying cassettes. Microsette duplication uses a proprietary high speed duplicator designed specifically for computer program duplication. The finished products are of consistent quality, guaranteed to load. Minimum order is 100 with discounts for higher quantities. Call (408) 735-8832 for details.



MICROSETTE CO.

777 Palomar Avenue

Sunnyvale, CA 94086

Circle 228 on inquiry card.

FIVE DISKLESS TRS-80 PROGRAMS:

- (1) TELEPHONE/ADDRESS/MAILING - NAME & ZIP SORT. EVEN RETRIEVES NAME FROM PHONE # . VERY QUICK ACCESS OF OVER 120 LISTINGS @ 16K, 300 @ 32K
- (2) CHECKBOOK - KEEP UP WITH THE BANK. CAN 170 EASILY ACCESSIBLE LISTINGS COVER A YEAR'S ACTIVITY?
- (3) TAX RECORDER - LISTS YOUR YEARLY TAX DEDUCTIBLE EXPENSES. ADDS ALL YOUR COLUMNS, SAVES PENCILS.
- (4) FOOD FOR THE HEAD - NUTRITIONAL CONTENTS OF FOODS, VITAMINS, MINERALS, AMINO ACIDS, CARBOHYDRATES, FATS, FIBER, PROTEIN, CALORIES. 16K \$40, 32K \$60
- (5) MANDALAS FOR THE CYBERNETIC AGE - WARNING: HIGHLY HYPNOTIC GRAPHICS. 2 SETS OF 4 INTERWEAVING DESIGNS ALL ABOVE LEVEL II, 16K \$30 OR AS NOTED.

LOWECO ALSO CARRIES MICROSOFT, TSE AND TBS FOR THE TANDY TRADEMARK TRS-80. SEND \$2 FOR CATALOG.

LOWECO COMPUTER

1803 RODNEY

LOS ANGELES CA 90027

213-660-7530

Money Order, Cashier Check Speeds Delivery
6% Sales Tax For Californians

Circle 207 on inquiry card.



The NEW Owners Of

Radio Hut

P.O. BOX 2015 GARLAND, TEXAS 75041

ORDER BY PHONE—214-324-5509

ANNOUNCE:
THE RETURN OF
RADIO HUT
SUPER SPECIALS!

The EXPANDORAM is available in versions from 16K up to 64K, so for a minimum investment you can have a memory system that will grow with your needs. This is a dynamic memory with the invisible on-board refresh, and IT WORKS!

- Bank Selectable
- Phantom
- Power 8VDC, +16VDC, 5 Watts
- Lowest Cost Per Bit
- Uses Major Brand 16K RAMS
- PC Board is doubled solder masked and has silk-screen parts layout
- Extensive documentation clearly written

SD EXPANDORAM



- Complete kit includes all Sockets for 64K
- Memory access time: 375ns, Cycle time: 500ns.
- No wait states required
- 16K boundaries and Protection via Dip Switches
- Designed to work with Z-80, 8080, 8085 CPU's

EXPANDORAM 64K Kit (16K Ram)

16K	\$219.00
32K	\$279.00
48K	\$359.00
64K	\$419.00
WITHOUT MEMORY	\$159.00

We carry a full line of SD Systems Products. Please write for catalog or call for prices

PROM - 100 PROM Programmer Board

The PROM-100 Programmer is a development tool for S-100 Bus computer systems. The Zero Insertion Force Programming Socket extends above the card cage height for easy access to PROM devices. Software verifies PROM erasure, verifies program loading and provides for reading of object file from Disk or PROM and programming into PROM/EPROM. Features include: On-board generated 25vdc Programming pulse, TTL compatible, maximum programming time for 16,389 bits is 100 seconds. Programs: 2708, Intel 2758, 2716, 2732 and TI 2516. DIP Selectable EPROM type.

PROM-100 Board Kit \$ 149.95

NEW! First Time Offered MPB-100 Z80 CPU Board Kit

The MPB-100 provides a Z80 microprocessor based CPU for S-100 Bus systems. Front panel usage is optional making the MPB-100 suitable for upgrading existing systems to Z80 level. A PROM socket is provided on-board which makes the MPB-100 adaptable to process control applications. Features include: Power-on Jump to 4K boundaries, 2 Megahertz or 4 Megahertz operation, optional wait states, on-board PROM socket.

MPB-100 Kit \$ 199.00

"VERSAFLOPPY" KIT

The Versatile Floppy Disk Controller
Only \$139.00

FEATURES: IBM 3740 Soft Sector'd Compatible. S-100 BNS Compatible for Z-80 or 8080. Controls up to 4 Drives (single or double sided). Directly controls the following drives:

1. Shugart SA400/450 Mini Floppy
2. Shugart SA800/850 Standard Floppy
3. PERSCI 70 and 277
4. MFE 700/750
5. CDC 9404/9406

BOWMAR 4 DIGIT READOUT ARRAY

4 Jumbo .50" Digits in One "Stick"!

The Bowmar Opto-Stick. The best readout bargain we have ever offered. Has four common cathode jumbo digits with all segments and cathodes brought out. Increased versatility since any of the digits may be used independently to fit your applications. Perfect for any clock chip, especially direct drive units like 50380 or 7010. Also use in freq. counters, DVM's etc. For 12 or 24 hour format. (With colons and AM/PM indicator.)

\$ 1.99



VDB-8024 Video Display Board

The VDB-8024 features its own on-board Z80 microprocessor. This gives the capability of using software (included in ROM) to control functions and enhancements without interference with the computer's CPU. Included in the special features: 80 characters by 24 lines display, Keyboard power and interface, Composite and separate video output, 2K on-board RAM, a total of 256 available characters, full cursor control, Forward and Reverse Scrolling, Underlining, Field Reverse, Field Protect enhancements, programmable characters.

VDB-8024 KIT \$ 319.00

TELE TAPE

Record important telephone conversations now with Tele Tape and your recorder. Each time your receiver is picked up your recorder will automatically start! When you hang-up the recorder stops. Tape will be extra clear so you can refresh your memory at a later date. Kit includes everything except the case and phono plugs.

Assembled & Tested Only \$ 29.95

MINIATURE SPEAKER SPECIAL!

2 INCH — .8 OHM.
PERFECT FOR CLOCKS! **\$.79**

TO-5 HEATSINKS*

Similar to Thermalloy 2205G
Finned with insert.
5 for \$1

ROCKER SWITCH*

HEAVY DUTY
S.P.D.T. 3A. 125 V.A.C.
New, modern styling! **5 for \$1**

Z80 STARTER KIT

SD System's Z80 Starter Kit enables the novice to build a complete microcomputer on a single board. Featuring the powerful Z80 microprocessor the Z80 Starter Kit features: • Keyboard and Display • Audio Interface • PROM Programmer • Expansion and Wire Wrap Area • On Board RAM • 4 Channel Counter/Timer • Z-BUG Monitor in PROM • I/O Ports.

This month's Special:

\$219.95 Kit \$369.95 A&T

SBC-100

SINGLE BOARD COMPUTER

The SBC-100 provides a complete micro-computer on a single board! The Z80 microprocessor is used as the heart of the SBC-100. The SBC-100 meets all the requirements of a Z80 CPU board with the added features of I/O ports, counter/timer channels, on board RAM, provisions for PROM/ROM and a software programmable baud rate generator. S-100 Bus compatible, the SBC-100 features are: 8K bytes of available PROM, 1024 bytes on-board RAM, Serial I/O with both synchronous and asynchronous operation, Parallel I/O ports, Optional Vectored Interrupts, and Four Counter/Timer Channels. SD Monitor available for RS-232 and Video Terminals. Disk based system software also available.

SBC-100 KIT \$ 219.00

COMPUTER CORNER

CPU's

Z80	10.99
Z80A	13.99

RELATED CHIPS

2114 (300ns)	5.99
Z80 PIO	9.95
Z80CTC	11.95
2708	8.99
4115	8 for 34.95
4116	8 for 80.00

DISC CONTROLLER

1771	29.95
------------	-------

Color Burst Crystal (3.57MHz) 89¢

TERMS:Add 30¢ postage, we pay balance. Orders under \$15 add 75¢ handling. No C.O.D. We accept Visa, MasterCharge, and American Express cards. Tex. Res. add 5% Tax. Foreign orders (except Canada) add 20% P&H. 90 Day Money Back Guarantee on all items

While in Dallas visit our retail store at Treehouse Shopping center. Garland Road and Jupiter.

What's New?

PERIPHERALS

Expand the PET Computer

A combination memory I/O (input/output) expander and floppy disk system for the PET computer is now available from CGRS Microtech. The PEDISK provides both a high-speed floppy disk and an S-100 expansion chassis all in one unit. The S-100 expansion will hold extra I/O and memory, such as printer, telephone interface, modem and voice I/O cards.

The floppy disk is available with up to 3 5-inch floppy disk drives (total capacity of 80 K bytes) or up to 4 8-inch disk drives (total capacity of 1 M bytes). System prices range from \$799.95. For further information, contact CGRS Microtech, POB 368, Southampton PA 18966.

Circle 582 on inquiry card.

Low Cost Selectric Typewriter Interface

The MP-WP Selectric Interface is a simple, low cost interface that allows the user to connect an unmodified IBM model 50 Selectric typewriter to an SS-50 bus 6800 or 6809 computer system. Interfacing is made to the typewriter through a cable assembly that plugs into a connector provided on the typewriter. No solenoids or typewriter modifications are required. The typewriter may be used for both input and output, and will still function as a normal typewriter when not being driven by the computer.

The interface and interconnecting cable (#MP-WP) are fully assembled and sell for \$59.95 postage paid. For further information, contact Southwest Technical Products Corp, 219 W Rhapsody, San Antonio TX 78216.

Circle 583 on inquiry card.

Free Brochure Describes Houston Instrument's Hi Pad Digitizer

An 8 page, 4 color brochure describing the Hi Pad Digitizer is available from Houston Instrument, One Houston Sq, Austin TX 78753. This 11 by 11 inch active surface digitizer offers user controllable features such as metric and inch capability, binary and binary-coded decimal outputs, RS-232C 8-bit parallel interface, all selectable at the interface connector.

The Hi Pad is accurate to ± 0.015 inches with a resolution of either 0.01 or 0.005 inches. The data rate may be set to input up to 100 coordinate pairs per second. Four buttons on the edge of the

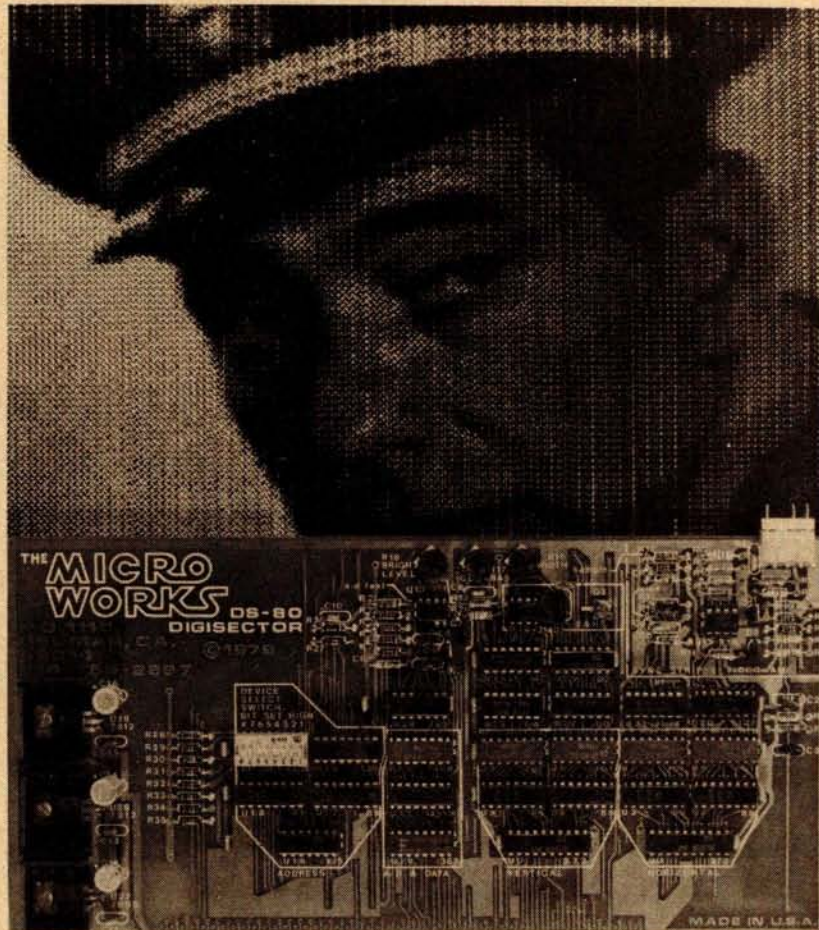

Random Access Video Digitizer

The DS-80 Digisector is a random access digitizer with high-resolution and speed. The board provides the following features: a 256 by 256 picture element scan; 64 levels of grey scale; conversion times as low as 4 μ s per pixel; accepts either interlaced (NTSC) or noninterlaced (industrial) video input; and uses 1 bus slot in any S-100 system conforming to the Institute of Electrical and Electronic Engineers (IEEE) standards.

table allow the user to relocate the origin and select point or stream modes of operation. The magnified cursor allows coordinate updating of the curve or line being traced by depressing the cursor button at points being considered.

The brochure includes prices and specifications for the Hi Pad and accessories as well as complete technical descriptions of the multiple output formats available with the Hi Pad.

Circle 584 on inquiry card.

The computer sends the Digisector 2 8-bit addresses (X and Y coordinates), and the Digisector returns the digitized brightness of the image at the specified location. For set-up and monitoring purposes, the Digisector produces an output comprised of the camera's video signal plus a superimposed cursor, showing exactly where the DS-80 is looking.

The software supplied will digitize 1 pixel every other horizontal scan-line, filling 8 K bytes of memory with 2 4-bit grey scale values per byte in a little less than 2 seconds. It provides spatial resolution of 128 by 128 elements, optimum for computer-portraiture and slow-scan television. This software is compatible with the Vector Graphic High-Resolution Graphics Display Board. Additional routines are provided to drive both graphics and American Standard Code for Information Interchange (ASCII) printers.

The Digisector comes fully assembled, tested, and burned-in and is priced at \$349.95. For further information, contact Micro Works, POB 1110, Del Mar CA 92014.

Circle 585 on inquiry card.

BK PRECISION Transistor Testers



MODEL 520B

Industrial Transistor Tester

- Now with HiLO Drive
- Works in-circuit when others won't
- Identifies all three transistor leads
- Random lead connection
- Audible and visually indicates GOOD transistor
- Automatic NPN/PNP determination
- Positive SiGe identification
- Tests diodes, SCR's, FET's, and Darlingtons
- CSA approved version available



MODEL 510

Portable Transistor Tester

- Fast GO/NO-GO in-circuit transistor testing
- Fast and thorough GOOD/BAD out-of-circuit testing
- Tests FET's and SCR's in-circuit or out-of-circuit
- Connect any test clip to any component lead
- Gives positive emitter-base-collector identification in LO drive—positive base identification in HI drive
- Light-Emitting Diodes indicate NPN/DC or PNP/DC
- Pocket-size—Over 100 hours of testing from single set of "AA" cells
- Digital stability—no adjustments, nothing to go out of calibration
- Includes carrying case and leads



MODEL 501A

Semiconductor Curve Tracer

- Display characteristic curves for all semiconductor devices on your scope
- Measures breakdown voltage non-destructively
- Identify unknown devices
- Complete with FP-5 probe

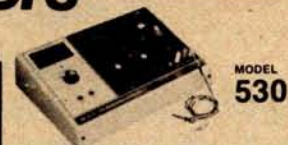

MODEL 530

Lab-Quality Semiconductor Tester...

- Measure I_c of bipolar transistors up to 1500 MHz
- Nondestructive testing of transistor and diode breakdown voltages
- Measures transistor beta or FET g_m
- Measures all transistor breakdown and leakage parameters
- Fast testing of transistors, FET's, and SCR's—in or out-of-circuit
- Base diagrams are not required
- No biasing information required
- Identifies all leads of transistors and SCR's
- Automatic identification of PNP/NPN types and N- or P-channel FET's

New from B&K ... Before you buy, check our prices...



MODEL 820

New Portable Digital Capacitance Meter

- Measures capacitance from 0.1pF to 1 Farad
- Resolves to 0.1pF
- 10 ranges for accuracy and resolution
- 4 digit easy-to-read LED display
- 0.5% accuracy
- Special lead insertion jacks or banana jacks
- Fuse protected
- Uses either rechargeable or disposable batteries
- Overrange indication



MODEL 3010

New Low Distortion Function Generator

- Generates sine, square and triangle waveforms
- Variable amplitude and fixed TTL square-wave outputs
- 0.1 Hz to 1MHz in six ranges
- Push button range and function selection
- Typical sine wave distortion under 0.5% from 0.1 Hz to 100 kHz
- Variable DC offset for engineering applications
- VCO external input for sweep-frequency tests

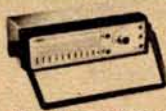

MODEL 3020

New Sweep/Function Generator

- Four instruments in one package—sweep generator, function generator, pulse generator, tone-burst generator
- Covers 0.02Hz-2MHz
- 1000:1 tuning range
- Low-distortion high-accuracy outputs
- Three-step attenuator plus vernier control
- Internal linear and log sweeps
- Tone-burst output in front-panel or externally programmable

50MHz Digital Probe



MODEL DP-50

New Digital Pulser Probe



MODEL DP-100

- Multi-family compatible with TTL, DTL, RTL, HTL, CMOS, MOS and HBL
- Displays DC to 50MHz
- Displays pulse presence and logic states
- Memory mode to "freeze" pulse display
- Pulse mode "stretches" short pulses
- 2 megohm input impedance
- Input overload protected
- Detects pulses to 10 nanoseconds
- Generates "one shot" pulse or continuous 5Hz pulse train
- Automatically senses logic state and changes state to its complement
- Multi-family compatible with TTL, DTL, RTL, HTL, HBL, MOS and CMOS
- High current drive will pull shunted logic outputs high or low
- Short duty cycle pulse will not damage circuitry under test
- Fully overload protected
- Compatible to DP-50 digital probe



MODEL 2815

New 3 1/2-Digit DMM with LCD Readout

- 0.1% DC accuracy
- 0.3% LCD display for high readability
- 100A current range
- Low battery warning
- Fully overload protected
- Auto zero and auto polarity
- Built-in test stand
- Only 8.1 x 4.2 x 1.4" deep
- 100V, 1000A, 0.01% resolution
- Battery life of over 100 hours
- Shielded to stay accurate in RF fields

Call TOLL FREE (800) 645-9518

In N.Y. State call (516) 752-0050

FORDHAM

RADIO SUPPLY CO., INC.
855R Conklin St.
Farmingdale, N.Y. 11735

YOUR ONE STOP DISCOUNT CENTER
Master Charge, Bank Americard, Visa, C.O.D.'s accepted.

Send for new catalog of over 3,000 items 164 pages of test equipment. CB, tools, tubes, components and electronic supplies.

ADD \$3.00 TO COVER SHIPPING, HANDLING & INSURANCE N.Y. Res. add approx. sales tax.

HICKOK 3 1/2 Digit Mini-Multimeter
MODEL LX 303 \$69.50

GOULD 15 MHz Dual Trace
Triggers in excess of 25 MHz
Model QS255 \$795 including probes

SENORE TV-VTR-MATV and Video Analyzer
Model VA48 \$875.00 Reg. \$975.00

ES CONTINENTAL SPECIALTIES 100 MHz 8-Digit Counter \$119.00
• 20 Hz-100 MHz Range • 6" LED Display • Fully Automatic
Includes 100 IPC chip-lead input cable manual
NOW AVAILABLE **PS500 500MHz Prescaler \$52.95**

CODE-A-PHONE Telephone Answering Devices
Wiremate Command Model 1400 \$199.95
Model BSR-129 \$29.95

Sinclair PDM35 \$52.95 digital MultiMeter

Auto Stereo 40 Watt Power Booster POW-40
Reg. \$24.95

Weller Xcelite Service Master Attache Style Tool Kit
Model 995M \$42.95
Model TC-100-ST \$269.95
Model 99P Roll Kit \$15.95

PORTABLE VOM MULTITESTER
20,000:1 VDC • 10,000:1 VAC
Model 1500 \$249.95
Model 1500 \$199.95

WAHL NEW ISO-TIP "Quick Charge"
1.2 units \$27.95
Model 7500 Cordless Soldering Iron \$17.95
Model 5800 Thermal Spot Circuit Solder \$22.50

Microflame Deluxe Gas Torch Kit
Model 4400 Reg. \$39.95 \$29.95

BK PRECISION 3 1/2-Digit Portable DMM
• Overload Protected • Battery or AC operation • 3" high LED Display
Auto Zeroing Model 2800
comes complete with test leads, operating manual and spare fuse

Weller Xcelite 3-Way High Fidelity Stereo Speaker System
Reg. \$139.00 \$69.50

Logic Monitor
• Automatically displays static and dynamic logic • Works with DTL, HTL, TTL and CMOS • 16 LED display • Circuit powered design
Model LM-1 \$52.95 complete

Remote Control for Lights & Appliances
4 Piece Starter Kit Reg. \$87.95 \$79.95
One (1) Command Console \$14.95
Two (2) Lamp Modules \$14.95
One (1) Appliance Module \$39.95

HICKOK Function Generator
Model '270 \$169.15

In-Dash AM/FM 8 Track Stereo C-777
\$52.50
AM/FM Cassette Stereo
CAS 888 \$57.50

NLS 15 MHz Mini Oscilloscope
Model MS 15
Reg. \$318.00 \$269.95

Magnifier LAMP
Model MG 10A \$49.50

Bearcat Scanner
Model 250 \$299.95

Regency Touch K 100 Scanner
Reg. \$269 \$199.95

BK PRECISION Substitution Box
Model 2910

Weller Controlled Output Soldering Station
Reg. \$75.00 Model WTCP-N \$45.00

30MHz Dual Trace with Delay Line
Reg. \$1050 \$889.95

Chess Challenger
Ten levels of play Model LCX \$179.95

RC Circuit Box/RCA-VIZ
• 36 resistors (15 ohms to 10 megohms)
• 18 capacitors (100 pF to 0.22 uF)
Model VC-412A Reg. \$40 \$36 includes test leads

30MHz Portable Frequency Counter
Reg. \$120.00 \$59.95

Check our prices
Call TOLL FREE (800) 645-9518
For N.Y. State call (516) 752-0050
MasterCharge • Bank Americard
COD • Check • Money Order
Add \$3.00 for shipping and insurance
C.O.D.'s Extra New York State residents add approx. sales tax

FREE 1979 Catalog

Function Generator
Model 2001 \$127.50
Sine, square, triangle and separate TTL Square wave output

Miniature High Fidelity Stereo Speaker System
Reg. \$139.00 \$69.50

Logic Probe
Model LP-1 \$40.00
• Compact, circuit powered complete
• Detects pulses as short as 50 ns
• Multi-family compatibility: DTL, TTL, HTL, CMOS

Logic Monitor
• Automatically displays static and dynamic logic • Works with DTL, HTL, TTL and CMOS • 16 LED display • Circuit powered design
Model LM-1 \$52.95 complete

Weller Controlled Output Soldering Station
Reg. \$75.00 Model WTCP-N \$45.00

FREE 1979 Catalog

Function Generator
Model 2001 \$127.50
Sine, square, triangle and separate TTL Square wave output

Miniature High Fidelity Stereo Speaker System
Reg. \$139.00 \$69.50

Logic Probe
Model LP-1 \$40.00
• Compact, circuit powered complete
• Detects pulses as short as 50 ns
• Multi-family compatibility: DTL, TTL, HTL, CMOS

Logic Monitor
• Automatically displays static and dynamic logic • Works with DTL, HTL, TTL and CMOS • 16 LED display • Circuit powered design
Model LM-1 \$52.95 complete

Weller Controlled Output Soldering Station
Reg. \$75.00 Model WTCP-N \$45.00

FREE 1979 Catalog

Function Generator
Model 2001 \$127.50
Sine, square, triangle and separate TTL Square wave output

Miniature High Fidelity Stereo Speaker System
Reg. \$139.00 \$69.50

Logic Probe
Model LP-1 \$40.00
• Compact, circuit powered complete
• Detects pulses as short as 50 ns
• Multi-family compatibility: DTL, TTL, HTL, CMOS

Logic Monitor
• Automatically displays static and dynamic logic • Works with DTL, HTL, TTL and CMOS • 16 LED display • Circuit powered design
Model LM-1 \$52.95 complete

Weller Controlled Output Soldering Station
Reg. \$75.00 Model WTCP-N \$45.00

FREE 1979 Catalog

Function Generator
Model 2001 \$127.50
Sine, square, triangle and separate TTL Square wave output

Miniature High Fidelity Stereo Speaker System
Reg. \$139.00 \$69.50

Logic Probe
Model LP-1 \$40.00
• Compact, circuit powered complete
• Detects pulses as short as 50 ns
• Multi-family compatibility: DTL, TTL, HTL, CMOS

Logic Monitor
• Automatically displays static and dynamic logic • Works with DTL, HTL, TTL and CMOS • 16 LED display • Circuit powered design
Model LM-1 \$52.95 complete

Weller Controlled Output Soldering Station
Reg. \$75.00 Model WTCP-N \$45.00

FREE 1979 Catalog

Function Generator
Model 2001 \$127.50
Sine, square, triangle and separate TTL Square wave output

Miniature High Fidelity Stereo Speaker System
Reg. \$139.00 \$69.50

Logic Probe
Model LP-1 \$40.00
• Compact, circuit powered complete
• Detects pulses as short as 50 ns
• Multi-family compatibility: DTL, TTL, HTL, CMOS

Logic Monitor
• Automatically displays static and dynamic logic • Works with DTL, HTL, TTL and CMOS • 16 LED display • Circuit powered design
Model LM-1 \$52.95 complete

Weller Controlled Output Soldering Station
Reg. \$75.00 Model WTCP-N \$45.00

FREE 1979 Catalog

Function Generator
Model 2001 \$127.50
Sine, square, triangle and separate TTL Square wave output

Miniature High Fidelity Stereo Speaker System
Reg. \$139.00 \$69.50

Logic Probe
Model LP-1 \$40.00
• Compact, circuit powered complete
• Detects pulses as short as 50 ns
• Multi-family compatibility: DTL, TTL, HTL, CMOS

Logic Monitor
• Automatically displays static and dynamic logic • Works with DTL, HTL, TTL and CMOS • 16 LED display • Circuit powered design
Model LM-1 \$52.95 complete

Weller Controlled Output Soldering Station
Reg. \$75.00 Model WTCP-N \$45.00

FREE 1979 Catalog

"We Will Beat Any Advertised Price"

FORDHAM
855R Conklin St. Farmingdale, N.Y. 11735

10% OFF 20% OFF

YOUR OWN TRS-80 SYSTEM AT TREMENDOUS SAVINGS

① TRS-80 Complete System

Includes: CPU/Keyboard, Power Supply, Video Monitor, Cassette Recorder, Manual, and Game Cassette.

② Line Printer

③ Mini Disk System

④ C-10 Cassettes

⑤ Verbatim Diskettes

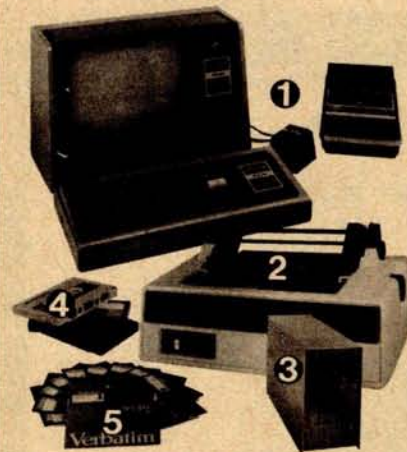

DISK DRIVES NOW IN STOCK!

ITEM	REG. PRICE	OUR PRICE
Level II—4K	\$698.00	\$628.20
Level II—16K	\$988.00	\$889.20
Expansion Interface	\$299.00	\$269.10
Mini Disk Drive	\$ 495.00	\$ 385.00
Centronics 779 Printer	\$1599.00	\$1175.00
Centronics 101 Printer	\$1595.00	\$1400.00
Anadex DP-8000 Printer	\$1295.00	\$ 995.00
Centronics P1 Printer	\$ 534.00	\$ 445.00
Trendata 1000	\$1495.00	\$1295.00
Memory Kit-(16K)	\$ 199.00	\$ 98.00
*FREE INSTALLATION		
Verbatim Diskettes ea.	\$ 5.95	\$ 4.95
3	\$ 17.89	\$ 12.00
10	\$ 59.00	\$ 37.00
Maxell Diskettes ea.	\$ 10.00	\$ 7.50
3	\$ 30.00	\$ 21.00
10	\$ 100.00	\$ 60.00
C-10 Cassettes	\$ 4.95	\$ 4.50
25	\$ 24.75	\$ 18.75
C-30 Cassettes	\$ 29.95	\$ 23.95
12		
Paper (9 1/2" x 11" fanfold, 3500 sheets)	\$ 35.00	\$ 29.95
TRS-80 MODEL II	\$3691.50	
• 32K RAM		481.50
• 1/2 MEG DISK		1230.50
ADDITIONAL 32K RAM		481.50
ADDITIONAL DISK DRIVE (1ST)		1230.50
ADDITIONAL DISK DRIVE (2ND + 3RD)		642.00

INNOVATIONS

Centronics 730 Same as Line Printer II

Special 1st 25 units sold
Similar to Line Printer III
\$ 850 Reg. \$ 895

Anadex 9500
\$1,295 Reg. \$1,999

* All printers include cables

There are new developments every day—write or call for the latest information.

Outlet Hours: Mon.-Fri.; 9 am.—7 pm.
Sat. 12—5 pm.

VRData corp.

777 Henderson Boulevard N-6
Folcroft Industrial Park
Folcroft PA 19032
(215) 461-5300



TOLL FREE

1-(800) 345-8102 *Orders only!

FOREIGN and DOMESTIC DISTRIBUTORSHIPS AVAILABLE . . .

BECKIAN ENTERPRISES

All Prime Quality — New Parts Only
Satisfaction Guaranteed

EDGE CARD CONNECTORS: GOLD PLATED. (Not Gold Flash)
BODY: Non brittle. Solvent res., G.E. Valox.
CONTACTS: Bifurcated; Phos/Bronze; Gold over Nickel.
ABBREVIATIONS: S/T Solder Tail; S/E Sold. Eyelet;
W/W Wire Wrap 3; SW/W Short W/Wrap;

PART #	Description	Row Sp.	1-4	5-9	10-24
5010	50/100 S/T ALTAIR	.140	3.75	3.50	3.30
5020	50/100 S/T IMSAI	.250	3.95	3.75	3.50
5030	50/100 W/W IMSAI	.250	4.10	3.90	3.70
5040	50/100 S/E ALT/IMSAI	.140	5.00	4.50	4.25
5050	50/100 S/T CROMEMCO	.250	6.25	6.00	5.75
1450	IMSAI CARD GUIDES		0.16	0.14	0.12
.100" Contact Center Connectors.					
1020	13/26 S/E Imsai MID.	.140	2.10	1.85	1.75
1040	25/50 S/E	.140	2.95	2.75	2.50
1050	25/50 S/T	.140	3.00	2.80	2.60
1060	36/72 W/W Vector.	.200	4.80	4.60	4.30
1065	36/72 S/T Vector.	.200	4.00	3.75	3.50
1070	40/80 S/E PET	.140	4.80	4.50	4.30
1075	40/80 W/W PET	.200	5.00	4.65	4.35
1080	40/80 S/T PET	.140	4.90	4.60	4.25
1085	43/85 S/E Cos.ELF	.140	5.00	4.75	4.50
1090	43/86 S/T Cos.ELF	.140	5.10	4.85	4.60
1093	43/86 S/T Cos.ELF	.200	4.95	4.70	4.45
1095	43/86 W/W Cos.ELF	.200	5.50	5.20	4.90
POLARIZING KEYS: For Above					
.156" Contact Center Connectors.					
1550	6/- S/E PET, Etc.	.140	1.30	1.10	0.90
1560	6/12 S/T PET/NSC.	.140	1.35	1.15	0.95
1575	12/24 S/E PET	.140	2.15	1.95	1.75
1580	12/24 S/T PET	.140	2.10	1.90	1.70
1590	15/30 S/E GRI Keybd.	.140	2.25	2.05	1.85
1620	18/36 S/E	.140	2.40	2.20	2.00
1650	22/44 S/E KIM, VECTOR	.140	2.20	2.00	1.80
1660	22/44 S/T KIM, VECTOR	.140	2.00	1.80	1.70
1670	22/44 W/W KIM, VECTOR	.200	2.40	2.20	2.00
1690	36/72 W/W	.200	3.90	3.75	3.50
1710	36/72 S/E	.140	3.50	3.30	3.10
1720	36/72 S/T	.200	3.30	3.10	2.90
1730	43/86 S/T Mot. 6800	.140	4.40	4.15	3.90
1740	43/86 S/T Mot. 6800	.200	4.35	4.10	3.85
1750	43/86 W/W Mot. 6800	.200	4.45	4.25	4.10
POLARIZING KEYS: For Above					

RS232 & 'D' TYPE SUBMINIATURE CONNECTORS:			
QUANTITY	1-4	5-9	10-24
DE9P Male	1.45	1.35	1.25
DE9S Female	1.93	1.80	1.70
DE110963-1	2pc. Grey Hood	1.20	1.10
DA15P Male		1.95	1.80
DA15S Female		2.80	2.60
DA51211-1	1pc. Grey Hood	1.25	1.15
DA110963-2	2pc. Grey Hood	1.22	1.10
DB25P Male		2.20	2.10
DB25S Female		3.20	3.00
DB51212-1	1pc. Grey Hood	1.30	1.20
DB51226-1A	2pc. Black Hood	1.40	1.30
DB110963-3	2pc. Grey Hood	1.35	1.25
DC37P Male		3.70	3.50
DC37S Female		4.90	4.70
DC110963-4	2pc. Grey Hood	1.95	1.85
DD50P Male		4.40	4.30
DD50S Female		4.90	4.70
DD51216-1	1pc. Grey Hood	2.30	2.10
DD110963-5	2pc. Grey Hood	2.40	2.20
D20418-2 Hardware Sets		0.75	0.65

I.C. SOCKETS, GOLD.
WIRE WRAP 3 TURN.
14 pin \$0.36 ea.
16 pin 0.38 ea.

I.C. SOCKETS.
Dip Solder, Tin.
14 pin \$0.15 ea.
16 pin 0.17 ea.

8080 PRIME
\$8.00 ea.

2708 EPROMS PRIME
\$14.00 ea.

CONNECTORS FOR CENTRONICS 700 SERIES:

Amphenol 57-30360 For Back of Centronics '700' Series:
Price: \$9.00ea. 5 pcs. \$7.50ea.

WHISPER FANS: Excellent for Computer cabinet cooling. Extremely quiet.
Dim. 4-3/4" x 1-1/2" thick. U.L. Listed. 1-4 5-9 10-24
\$22.00 \$19.00 \$18.00

WRITE FOR LARGER QUANTITY DISCOUNTS. DEALER INQUIRIES ARE WELCOME.

WE ARE CONNECTOR (EDGE CARD) SPECIALISTS. IF YOU DO NOT SEE WHAT YOU NEED IN THIS ADVERTISEMENT, PLEASE WRITE US. WE WILL REPLY.

TERMS: Minimum Order \$10.00. Add \$1.25 for handling and shipping. All orders over \$25.00 in USA and Canada: WE PAY THE SHIPPING.

NOTE: CA residents please add 6% sales tax.

NO C.O.D. SHIPMENTS OR ORDERS ACCEPTED.

MAIL ORDERS TO:

Beckian Enterprises
P.O. Box 3089
Simi Valley, CA 93063

10-DAY FREE TRIAL

Send for our
FREE Catalog

WE BUY USED PET, APPLE and TRS-80 COMPUTERS



\$100 FREE ACCESSORIES WITH 16K or 32K PET

Buy our 16K or 32K PET and we'll give you your first \$100 worth of accessories. **FREE.** Just indicate on your order that you have reduced the cost of your accessories by \$100.

FREE Terminal Package with PETs

SAVE \$69

4K - Keyboard C	\$ 595
8K - Keyboard C	\$ 795
16K - Keyboard B	\$ 995
16K - Keyboard N	\$ 995
32K - Keyboard C	\$1195
32K - Keyboard B	\$1195
32K - Keyboard N	\$1195
C — calculator keyboard (only version with tape deck)	
B — Large Keyboard (graphics not on keys)	
N — large keyboard with graphics symbols	
Used 8K PET with 90-day warranty	\$650



Hazeltine 1400

LIST SALE

~~\$850~~ ~~\$749~~

SUPER SALE PRICE TOO LOW TO ADVERTISE

Immediate Delivery — 2-Year Factory Warranty

You may have seen the Hazeltine advertised at \$850. You may have seen it sale prices at \$749 or even \$699 but our new price is so low that we can't even advertise it. Call us for a quote. Hurry, we have a limited quantity at this price. The 8048-based Hazeltine 1400 has a 12" screen, 24 x 80 display, TTY-style keyboard, addressable cursor, and RS-232 I/O from 110 to 9600 baud.

Hazeltine 1410 — \$835
Hazeltine 1500 — \$1069

Hazeltine 1510 — \$1195
Hazeltine 1520 — \$1499



apple II plus

\$200 FREE ACCESSORIES

The new Apple II with Applesoft BASIC built-in! Eliminates the need for a \$200 Firmware Card and includes new Autostart ROM for easy operation. This combined with the FREE accessories from NCE could save you up to \$400 on a 48K Apple II system!

16K Apple II Plus — \$1195 (take \$100 in free accessories)
32K Apple II Plus — \$1345 (take \$150 in free accessories)
48K Apple II Plus — \$1495 (take \$200 in free accessories)

Apple II Accessories

Centronics Printer Interface	\$225
Disk and Controller	Call for Availability \$595
Second Disk Drive	\$495
Parallel Printer Card	\$180
Communications Card	\$225
Hi-Speed Serial Card	Call for Availability \$195
Firmware Card	\$200
Hobby/Proto Card	\$24
Microverter RF Mod.	\$35
Sanyo M2544 Recorder	\$55

IN STOCK NOW!

EVERY ITEM IN THIS ADVERTISEMENT IS IN STOCK AND READY TO SHIP, EXCEPT WHERE NOTED.

NOW Graphics printer \$1,098 for Apple II

Now you can print high resolution graphics from your Apple using the IP-225 printer and graphics option from IDS. The IP-225 is a tractor feed printer with 96 possible characters. Line length is 80/132 col. with a speed of 50/80 cps. We include software which allows it to use either parallel or serial interface at 1200 baud. **ABSOLUTELY FREE** (you save \$50)!

CompuMart

SELLING COMPUTERS BY MAIL SINCE 1971

1250 North Main Street, Department BYA9
P.O. Box 8610 Ann Arbor, Michigan 48107

(313) 994-3200



Member:
Computer Dealers
Association



PET OWNERS ...

REMOTE TERMINAL for only \$69

A self-contained module and program cassette enables your PET to function as a 300 baud terminal. Supports Upper/Lower case, Rubout, Escape & all control functions. Output is TTL.

FREE WITH PET PURCHASE

NEW! 400K DISK & MEMORY EXPANSION

You can instantly turn your PET into a speedy and efficient professional computer. Its easy with the new 400K Disk Drive and Memory Expansion from Computhink Add up to 32K internally then load 20K program in only 3 seconds!

400K Disk Drive	\$1,295.00
Memory Expansion 16K	\$425.00
24K	\$525.00
32K	\$615.00

Selectric-Based Desktop Terminal \$319



Super bargain, while they last. A desktop terminal based on an IBM Selectric typewriter for only \$319, including documentation. These terminals were originally designed for use with timesharing systems where top-quality printing was required. The IBM keyboard and printer are separated by a three foot cable and each has its own enclosure (great for custom installations). Serial RS-232 interface uses PTTC instead of ASCII codes so you will need to write a conversion program (we have no ASCII interface for this model). 14.8 cps, 134.5 baud, 13" line length, pica. Sold in "AS-IS" condition. Pre-sale preparations include:

- Motors checked and guaranteed before sale.
- The machines are complete.
- All indicator lights work.
- New ribbon & cleaned type element, on/off switches, tab & carriage return cards, & tab set clear.

There is a 3-day return privilege on these machines and any missing parts will be replaced.



CAT COUPLER

New 300 baud Originate, Answer Acoustic Coupler. Looks good, works great

priced at **\$189**

LOW COST PRINTER FOR PET

\$395

This is a completely refurbished Teletype K509.33 terminal ready to attach to your PET's interface to use as a printer.

IN STOCK NOW

1+1=3-RIGHT!

EDUCATORS ORDER YOUR FREE PET TODAY!

Between now and Nov. 30th any educational institution which buys 2 PET's at list price will receive a 3rd PET. **ABSOLUTELY FREE!** That's right, FREE! For example, buy 2 8K PET's at \$795 each and get 1 8K PET. FREE. Buy 1 16K at \$995 and 1 32K at \$1,295 and your school will receive 1 16K PET absolutely FREE! Join the hundreds of public & private schools, colleges, and Universities who have bought from us with confidence. Look at our PET box in the upper left hand corner of this ad for descriptions and prices of the Commodore PET product line. If you need more information just call, we love questions.

SANYO MONITOR

\$169 **\$279**

9-inch ~~\$240~~ 15-inch ~~\$400~~



IMPORTANT ORDERING INFORMATION

All orders must include 4% shipping and handling. Michigan residents add 4% for state sales tax. All foreign orders (except Canada) need an additional 10% for shipping and handling.

Phones open from 9:00 a.m. to 7:00 p.m. EST Monday-Friday, 10:00 a.m. to 5:00 p.m. Saturdays • P.O.'s accepted from D & B rated companies — shipment contingent upon receipt of signed purchase order • All prices subject to change without notice • Most items in stock for immediate shipment — call for delivery quotation • Sorry, no C.O.D.'s • In the Ann Arbor area? Retail store open 11:00 a.m. to 7:00 p.m. Tuesday-Friday, 10:00 a.m. to 5:00 p.m. Saturdays (Closed Sunday and Monday)

If not satisfied, return your purchase with-in 10 days for full refund of purchase price!

C/MOS (DIODE CLAMPED)			
4001	-22	4024	-75
4002	-22	4025	-22
4003	-22	4027	-45
4004	-45	4028	-80
4005	-45	4029	-95
4011	-22	4030	-25
4012	-22	4035	-97
4013	-40	4042	-86
4014	-1.20	4044	-1.20
4015	-1.00	4045	-1.20
4016	-45	4046	-1.95
4017	-1.05	4049	-75
4018	-90	4050	-45
4019	-45	4051	-1.10
4020	-1.10	4053	-1.10
4021	-1.10	4055	-1.25
4022	-1.00	4056	-1.70
4023	-22	4058	-75

PRINTED CIRCUIT BOARD	
4" x 6" DOUBLE SIDED EPOXY BOARD 1/16" thick \$ 8.00 ea.	5/32.60
7 WATT LD-65 LASER DIODE IR \$8.95	
25 watt Infra Red Pulse 1 SG 2006 equiv. Laser Diode (Spec sheet included) \$24.95	
MINIATURE MULTI-TURN TRIM POTS	
100, 1K, 2K, 5K, 10K, 20K, 50K, 200K, 1Meg, 2Meg, \$7.5 each 3/32.00	
2N 3820 P FET \$ 45	
2N 5457 N FET \$ 45	
2N2646 UJT \$ 45	
ER 900 TRIGGER DIODES 4 \$1.00	
2N 6028 PROG. UJT \$ 65	

TRANSISTOR SPECIALS	
2N6233 NPN SWITCHING POWER \$ 1.95	
MRF-8004 a CB RF Transistor NPN \$ 7.5	
2N3772 NPN Si TO 3 \$ 1.00	
2N1546 PNP GE TO 3 \$.75	
2N4908 PNP Si TO 3 \$ 1.00	
2N5086 PNP Si TO 92 4 \$ 1.00	
2N3137 NPN Si RF \$.55	
2N3919 NPN Si TO 3 RF \$ 1.50	
2N1420 NPN Si TO 5 \$ 1.00	
2N3767 NPN Si TO 66 \$.70	
2N2222 NPN Si TO 18 \$ 1.00	
2N3085 NPN Si TO 3 \$.60	
2N3904 NPN Si TO 92 6/5 \$ 1.00	
2N3906 PNP Si TO 92 \$ 1.00	
2N5296 PNP Si TO 220 \$.50	
2N6109 PNP Si TO 220 \$.55	
2N7638 PNP Si TO 18 \$ 1.00	
MP5A 13 NPN Si \$ 1.00	

Full Wave Bridges			DIP SOCKETS	
PRV 2A	6A	25A	8 PIN 17 24 PIN .35	
100		1.40	14 PIN .20 28 PIN .40	
200	80	1.30	2.20	16 PIN .22 40 PIN .60
400	1.00	1.65	3.30	18 PIN .25
600	1.30	1.90	4.40	

1688 RD232 INTERFAC	\$1.40	UPD0141-4K STAT. RAM	9.95
1689 RD232 INTERFAC	1.25	8116-2	4.95
2006 TRI STATE STAT. SR	1.35	8260/21078 4K DYN RAM	3.40
2013 CHARG. CDR. I.P.	6.75	7MS 4002L	1.95
2018KEX 32 BIT SR	2.25	3204 4K PROM	9.95
3632 STATIC DHP F REG.	1.95	8323	3.95
3708 BC EPROM 4Kx16	2.35	8329-29	3.25
7108-240N NC 80 BITS DYN SR	1.35	2012C	2.75
7118-170 3 VOLT TMR	35.95	2011	2.05
7119-100 3 VOLT TMR	35.95	2011	2.05
2103 14400 Hz	.99	AYS 1013 VART	5.25
2103 14400 Hz	.99	TR1 6028	4.95
2103 14400 Hz	1.25	8703C TELETYPE BRIT AD	4.95
400200 MK II DYN	2.45	CONVERT	1.95
MX400P	1.95	PT 1428 PAKT	6.95
2101 1254 4 STATIC	2.45	8080A	1.95
2110 1254 4 STATIC	2.45	8276	4.95
2110 1254 4 STATIC	2.70	8228	2.95
2114 4K STAT. RAM 14600 Hz	1.95	8295.5	16.00
2113 36K DYN RAM	1.80	8291	13.50
8130 - 2.35	87380 - 2.25	8884 - 2.25	
8131 - 2.95	8830 - 3.95	8833 - 2.25	

VERIPAK PC BOARD	
Old new Prototyping board in a to demony 4 1/2" x 6 1/2" single sided 117E-G10 board. It will handle 40, 24, 16 134 units, 14 + 8 pin IC's. There are three buses, 15V, ground and a floating bus. There is a pad for a TO-220 regulator. There is a 22 pin edge connector with 150' spacing.	\$12.95
FP 100 PHOTO TRANS. RED, YELLOW, GREEN	\$.50
LARGE LED'S	\$ 6.00
TIL-118 OPTO-ISOLATOR	\$.75
MCT-6 OPTO ISOLATOR	\$.80
1 WATT ZENERS: 3.3, 4.7, 5.1, 5.6, 9.1, 10, 12, 15, 18, or 22V	\$ 6.00
MCM 6571A 7 x 9 character gen.	\$ 10.75

TLT IC SERIES	
7460	32
7461	22
7462	22
7463	22
7464	27
7465	27
7466	34
7467	34
7468	34
7469	34
7470	34
7471	34
7472	34
7473	34
7474	34
7475	34
7476	34
7477	34
7478	34
7479	34
7480	34
7481	34
7482	34
7483	34
7484	34
7485	34
7486	34
7487	34
7488	34
7489	34
7490	34
7491	34
7492	34
7493	34
7494	34
7495	34
7496	34
7497	34
7498	34
7499	34
7500	34

SANKEN AUDIO POWER AMPS	
Si 1010 G 10 WATTS	\$ 7.80
Si 1020 G 20 WATTS	\$15.70
Si 1050 G 50 WATTS	\$28.50

8" DISKETTES - HARD SECTOR	
	\$1.75, 10/\$16.00
CRYSTALS \$3.45 ea.	
2.000 MHz	6.144 MHz
4.000 MHz	8.000 MHz
3.57 MHz	10.000 MHz
5.000 MHz	20.000 MHz
6.000 MHz	

Silicon Power Rectifiers	
PRV 1A 3A 12A 50A 175A 280A	
100 06 14 35 50 3 70 5 00	
200 07 20 40 130 4 75 6 50	
400 09 25 65 150 6 50 9 50	
600 11 30 80 2 00 8 50 12 50	
800 15 35 1 00 2 50 10 50 16 50	
1000 20 45 1 00 3 00 12 50 20 00	

UNIVERSAL 4Kx8 MEMORY BOARD KIT	
32-2102-1 fully buffered, 16 address lines, on board decoding for any 4 of 64 pages, standard 4 pin bus, may be used with F-8 & KIM	\$69.95

74LS SERIES	
74LS00	74LS137
74LS01	74LS138
74LS02	74LS139
74LS03	74LS14
74LS04	74LS15
74LS05	74LS16
74LS06	74LS17
74LS07	74LS18
74LS08	74LS19
74LS09	74LS20
74LS10	74LS21
74LS11	74LS22
74LS12	74LS23
74LS13	74LS24
74LS14	74LS25
74LS15	74LS26
74LS16	74LS27
74LS17	74LS28
74LS18	74LS29
74LS19	74LS30
74LS20	74LS31
74LS21	74LS32
74LS22	74LS33
74LS23	74LS34
74LS24	74LS35
74LS25	74LS36
74LS26	74LS37
74LS27	74LS38
74LS28	74LS39
74LS29	74LS40

SILICON SOLAR CELLS	
4" diameter .4V at 1 AMP	\$10.00
FND 359 C.C. 4" \$ 60	
FCS 8024 4 digit	
C.C. 8" display	\$5.95
FND 5023 C.C. 5"	\$ 85
FND 510 C.C. 5"	\$ 85
DL 704 3" C.C.	\$ 85

REGULATORS	
323K - 5V 3A	\$ 5.75
309K	\$ 1.60
723	\$.50
320T	\$ 1.40
5, 12, or 15 V	\$ 1.40
78M05	\$ 7.5

CLOCK CHIPS	
MM5387AA	\$6.95
M7001	\$7.50
MM5311	\$3.75

TRIACS	
PRV 1A	10A
100	80
200	80
400	1.00
600	2.00

Terms: FOB Cambridge, Mass. Send Check or Money Order. Include Postage, Minimum Order \$5.00, COD'S \$20.00

SOLID STATE SALES
P.O. BOX 74B
SOMERVILLE, MASS. 02143 TEL. (617) 547-7053

WE SHIP OVER 95% OF OUR ORDERS THE DAY WE RECEIVE THEM

FREE UP TO \$170 IN MERCHANDISE WITH THE PURCHASE OF ONE OF THE FOLLOWING PET-CBM ITEMS!!



- ASK ABOUT EDUCATIONAL DISCOUNTS ON PET
- Axiom EX-801 PET Printer (with graphics) \$475.00
 - Axiom EX-820 PET Plotter \$790.00
 - Atari 400 and 800 Write for Price
 - IEEE - RS232 Printer Adaptor for PET \$ 79.50
 - BETSI PET to S-100 Interface & Motherboard \$119.00
 - PET Connectors-Parallel or IEEE \$ 1.95
 - Cassette Port \$ 1.45
 - Personal Information Management System- \$ 8.90
 - Protect-A-Pet dust cover \$ 9.50
 - Programmers Toolkit - PET ROM Utilities \$ 45.00
 - Microchess for PET (Peter Jennings) \$ 17.90
 - PET 4 Voice Music Board (MTUK-1002-2) \$ 44.90
 - Music Software (K-1002-3C) for PET \$ 16.90
 - CmC Word Processor program for PET \$ 25.00
 - Bridge Challenger program for PET \$ 13.45
 - Adventure 1 for 24K PET \$ 7.95
 - Adventure 2 for 24K PET \$ 7.95
 - Tunnel Vision/Kat & Mouse-maze - PET \$ 7.95
 - Graphics Utility Package for PET \$ 13.45
 - Stimulating Simulations-Book & PET tape \$ 13.45
 - Kite Fight - 2 player action game - PET \$ 7.95
 - Write for PET Software List
 - Drive Test - machine language arcade game \$ 4.90
 - Word Processor for PET - Machine Language version. Auto scroll, insert, delete, form letter append, etc.
 - 8K Version \$24.00 16K or 32K with disk \$95.00

PET SPECIALS

- PET 16N 16K full size graphics keyboard \$ 995
- PET 16B 16K full size business keyboard \$ 995
- PET 32N 32K full size graphics keyboard \$1295
- PET 32B 32K full size business keyboard \$1295
- PET 8K 8K small keyboard, integral cassette \$ 795
- PET 2040 Dual Disk Drive - 343,000 bytes \$1295
- PET 2022 Tractor Feed Printer \$ 995
- PET 2023 Pressure Feed Printer \$ 849
- PET C2N External Cassette Deck \$ 95

- LIST FREE*
- KIM-1 \$159 (Add \$30 for Power Supply)
 - SYM-1 \$222
 - BAS-1 Microsoft ROM Basic for SYMS \$ 85
 - Memory Plus \$199
 - SYM Assembler in ROM \$ 85
 - SEA-16 New 16K Static RAM \$325
 - Seawell Motherboard-4K RAM \$139
 - KTM-2 Synertek Keyboard and Video Interface with Graphics \$290
 - RAM 16 4MHz 16K Static RAM \$270
 - 2716 EPROM (5 volt) \$ 45
 - 6550 RAM (for 8K PET) \$12.70
 - 6502 Microprocessor Chip \$ 9.95
 - 6522 VIA \$ 9.75
 - 6520 PIA \$10.50

WRITE FOR 6502 AND S-100 PRODUCT LIST

FREE! UP TO \$170 IN MERCHANDISE



MINIMUM ORDER \$10.00

- 2114 L 450ns \$5.70 24 @ \$5.15 100 @ \$4.45
- BOOKS**
- Hands on Basic with a PET \$ 9.90
 - Programming the 6501 (Zaks) \$ 9.90
 - 6502 Applications Book (Zaks) \$11.90
 - 6500 Programming Manual (MOS) \$ 6.50
 - 6500 Hardware Manual \$ 6.50
 - Programming a Microcomputer: 6502 \$ 8.90
 - Basic for Home Computers \$ 5.90
- 3M "Scotch" 8" disks SALE 10/\$31**
- 3M "Scotch" 5" diskettes SALE 10/\$35**
- Verbatim 5" diskettes 10/\$27
- Diskette Storage Pages each \$4.5
- (Write for quantity prices)
- Cassettes (all tapes guaranteed)**
- Premium quality, high output lownoise in 5 screw housing with labels:
- C-10 10/5.95 50/25.00 100/48.00
 - C-30 10/7.00 50/30.00 100/57.00
- 115-B E. Stump Road
Montgomeryville, PA 18936
(215) 699-8386



ATTENTION ELF OWNERS ANNOUNCING QUEST SUPER BASIC

At last a Full Size Basic for 1802 systems. A complete function Basic including two dimensional arrays, string variables, floating point, arithmetic and 32 bit signed integer arithmetic (10 digit accuracy) with I/O routines. Easily adaptable on most 1802 systems. Requires 12K RAM minimum for Basic and user programs. Cassette version in stock now for immediate delivery. ROM versions coming soon with exchange privilege allowing credit for cassette version.

Super Basic on Cassette **\$40.00**

RCA Cosmac Super Elf Computer \$106.95

Compare features before you decide to buy any other computer. There is no other computer on the market today that has all the desirable benefits of the Super Elf for so little money. The Super Elf is a small single board computer that does many big things. It is an excellent computer for training and for learning programming with its machine language and yet it is easily expanded with additional memory. Fully Basic, ASCII Keyboards, video character generation, etc.

Before you buy another small computer, see if it includes the following features: ROM monitor; State and Mode displays; Single step; Optional address displays; Power Supply; Audio Amplifier and Speaker; Fully socketed for all IC's; Real cost of in warranty repairs; Full documentation.

The Super Elf includes a ROM monitor for program loading, editing and execution with SINGLE STEP for program debugging which is not included in others at the same price. With SINGLE STEP you can see the microprocessor chip operating with the unique Quest address and data bus displays before, during and after executing instructions. Also, CPU mode and instruction cycle are decoded and displayed on 8 LED indicators.

An RCA 1861 video graphics chip allows you to connect to your own TV with an inexpensive video modulator to do graphics and games. There is a speaker system included for writing your own music or using many music programs already written. The speaker amplifier may also be used to drive relays for control purposes.

Super Expansion Board with Cassette Interface \$89.95

This is truly an astounding value! This board has been designed to allow you to decide how you want it optioned. The Super Expansion Board comes with 4K of low power RAM fully addressable anywhere in 64K with built-in memory protect and a cassette interface. Provisions have been made for all other options on the same board and it fits neatly into the hardwood cabinet alongside the Super Elf. The board includes slots for up to 6K of EPROM (2708, 2758, 2716 or TI 2716) and is fully socketed. EPROM can be used for the monitor and Tiny Basic or other purposes.

A 1K Super ROM Monitor \$19.95 is available as an on board option in 2708 EPROM which has been preprogrammed with a program loader/editor and error checking multi file cassette read/write software, (relocatable cassette file) another exclusive from Quest. It includes register save and readout, block move capability and video graphics driver with blinking cursor. Break points can be used with the register save feature to isolate program bugs quickly, then follow with single step. The Super Monitor is written with subroutines allowing users to take advantage of

Tiny Basic Source now available **\$10.00**
S-100 Slot Expansion. Add 3 more S-100 slots to your Super Expansion Board or use as a 4 slot S-100 Mother Board. Board without connectors **\$9.95.**

Coming Soon: High resolution alpha/numerics with color graphics expandable up to 256 x 192 resolution for less than \$100. Economical versions for other popular 1802 systems also.

16K Dynamic RAM board expandable to 32K for less than \$150.

A 24 key HEX keyboard includes 16 HEX keys plus load, reset, run, wait, input, memory protect, monitor select and single step. Large, on board displays provide output and optional high and low address. There is a 44 pin standard connector slot for PC cards and a 50 pin connector slot for the Quest Super Expansion Board. Power supply and sockets for all IC's are included in the price plus a detailed 127 pg. instruction manual which now includes over 40 pgs. of software info. including a series of lessons to help get you started and a music program and graphics target game.

Many schools and universities are using the Super Elf as a course of study. OEM's use it for training and research and development.

Remember, other computers only offer Super Elf features at additional cost or not at all. Compare before you buy. Super Elf Kit \$106.95, High address option \$8.95, Low address option \$9.95. Custom Cabinet with drilled and labelled plexiglass front panel \$24.95. Expansion Cabinet with room for 4 5-100 boards \$41.00. NiCad Battery Memory Saver Kit \$6.95. All kits and options also come completely assembled and tested.

Questdata, a 12 page monthly software publication for 1802 computer users is available by subscription for \$12.00 per year.

Tiny Basic Cassette \$10.00, on ROM \$38.00, original Elf kit board \$14.95.

monitor functions simply by calling them up. Improvements and revisions are easily done with the monitor. If you have the Super Expansion Board and Super Monitor the monitor is up and running at the push of a button.

Other on board options include Parallel Input and Output Ports with full handshake. They allow easy connection of an ASCII keyboard to the input port. RS 232 and 20 mA Current Loop for teletype or other device are on board and if you need more memory there are two S-100 slots for static RAM or video boards. A Godbout 8K RAM board is available for \$135.00. Also a 1K Super Monitor version 2 with video driver for full capability display with Tiny Basic and a video interface board. Parallel I/O Ports \$9.95, RS 232 \$4.50, TTY 20 mA I/F \$1.95, S-100 \$4.50. A 50 pin connector set with ribbon cable is available at \$12.50 for easy connection between the Super Elf and the Super Expansion Board.

The Power Supply Kit for the Super Expansion Board is a 5 amp supply with multiple positive and negative voltages \$29.95. Add \$4.00 for shipping. Prepunched frame \$7.50. Case \$10.00. Add \$1.50 for shipping.

Multi-volt Computer Power Supply
8v 5 amp, ±18v 5 amp, 5v 1.5 amp, -5v 5 amp, 12v 5 amp, -12v option, ±5v, ±12v are regulated. Kit \$29.95. Kit with punched frame \$37.45. Woodgrain case \$10.00.

60 Hz Crystal Time Base Kit \$4.40
Converts digital clocks from AC line frequency to crystal time base. Outstanding accuracy. Kit includes: PC board, IC, crystal, resistors, capacitors and trimmer.

Same day shipment. First line parts only. Factory tested. Guaranteed money back. Quality IC's and other components at factory prices.

INTEGRATED CIRCUITS

7408TTL	LM3177K	2.92	CD4015	.66
7402N	LM318	1.35	CD4016	.36
7402N	LM320K	1.25	CD4017	.31
7404N	LM323K	5.95	CD4018	.94
7409N	LM320T-12	1.35	CD4019	.26
7410N	LM320T-15	1.35	CD4020	.26
7414N	LM320T-5	1.60	CD4021	1.02
7420N	LM320T-12	1.50	CD4022	1.60
7420N	LM320T-15	1.60	CD4023	1.60
7420N	LM320T-5	1.60	CD4024	.75
7420N	LM320N	1.15	CD4025	.26
7420N	LM329N	1.55	CD4026	1.51
7447H	LM340K-5	1.35	CD4027	.36
7448N	LM340K-8	1.35	CD4028	.79
7450N	LM340K-12	1.35	CD4029	1.02
7474N	LM340K-15	1.35	CD4030	.28
7475N	LM340K-24	1.35	CD4031	1.02
7485N	LM340T-5	1.25	CD4040	1.02
7489N	LM340T-12	1.25	CD4042	.47
7489N	LM340T-15	1.25	CD4043	.63
7489N	LM340T-24	1.25	CD4044	.83
7489N	LM340T-30	1.25	CD4045	1.33
7489N	LM340T-36	1.25	CD4046	.36
74100N	LM343H	4.50	CD4050	1.46
74107H	LM35	2.50	CD4052	1.13
74121H	LM370	1.15	CD4060	.32
74122H	LM377	3.00	CD4068	.71
74125H	LM380N	1.00	CD4069	.40
74150N	LM381	1.60	CD4070	.40
74154N	LM382	1.60	CD4071	.28
74162N	LM735N	87	CD4072	.28
74162N	LM735N	87	CD4073	.28
74191H	LM732H	50	CD4075	.28
74191H	LM732H	50	CD4076	.28
74174N	LM741N	.25	CD4081	.28
74175N	LM747H	.62	CD4082	.28
74192H	LM747H	.39	CD4118	.47
74192H	LM750N	.82	CD4490	5.00
74192H	LM750N	1.10	CD4491	1.40
74209H	LM750N	1.27	CD4508	2.25
74209H	LM750N	2.00	CD4510	1.02
74209H	LM750N	4.75	CD4511	1.34
74209H	LM750N	4.75	CD4512	1.34
74209H	LM750N	1.75	CD4516	1.10
74209H	LM750N	1.00	CD4520	1.02
74209H	LM750N	1.00	CD4521	1.02
74209H	LM750N	1.00	CD4522	1.51
74209H	LM750N	1.00	CD4523	1.51
74209H	LM750N	1.00	CD4524	1.51
74209H	LM750N	1.00	CD4525	1.51
74209H	LM750N	1.00	CD4526	1.51
74209H	LM750N	1.00	CD4527	1.51
74209H	LM750N	1.00	CD4528	1.51
74209H	LM750N	1.00	CD4529	1.51
74209H	LM750N	1.00	CD4530	1.51
74209H	LM750N	1.00	CD4531	1.51
74209H	LM750N	1.00	CD4532	1.51
74209H	LM750N	1.00	CD4533	1.51
74209H	LM750N	1.00	CD4534	1.51
74209H	LM750N	1.00	CD4535	1.51
74209H	LM750N	1.00	CD4536	1.51
74209H	LM750N	1.00	CD4537	1.51
74209H	LM750N	1.00	CD4538	1.51
74209H	LM750N	1.00	CD4539	1.51
74209H	LM750N	1.00	CD4540	1.51
74209H	LM750N	1.00	CD4541	1.51
74209H	LM750N	1.00	CD4542	1.51
74209H	LM750N	1.00	CD4543	1.51
74209H	LM750N	1.00	CD4544	1.51
74209H	LM750N	1.00	CD4545	1.51
74209H	LM750N	1.00	CD4546	1.51
74209H	LM750N	1.00	CD4547	1.51
74209H	LM750N	1.00	CD4548	1.51
74209H	LM750N	1.00	CD4549	1.51
74209H	LM750N	1.00	CD4550	1.51
74209H	LM750N	1.00	CD4551	1.51
74209H	LM750N	1.00	CD4552	1.51
74209H	LM750N	1.00	CD4553	1.51
74209H	LM750N	1.00	CD4554	1.51
74209H	LM750N	1.00	CD4555	1.51
74209H	LM750N	1.00	CD4556	1.51
74209H	LM750N	1.00	CD4557	1.51
74209H	LM750N	1.00	CD4558	1.51
74209H	LM750N	1.00	CD4559	1.51
74209H	LM750N	1.00	CD4560	1.51
74209H	LM750N	1.00	CD4561	1.51
74209H	LM750N	1.00	CD4562	1.51
74209H	LM750N	1.00	CD4563	1.51
74209H	LM750N	1.00	CD4564	1.51
74209H	LM750N	1.00	CD4565	1.51
74209H	LM750N	1.00	CD4566	1.51
74209H	LM750N	1.00	CD4567	1.51
74209H	LM750N	1.00	CD4568	1.51
74209H	LM750N	1.00	CD4569	1.51
74209H	LM750N	1.00	CD4570	1.51
74209H	LM750N	1.00	CD4571	1.51
74209H	LM750N	1.00	CD4572	1.51
74209H	LM750N	1.00	CD4573	1.51
74209H	LM750N	1.00	CD4574	1.51
74209H	LM750N	1.00	CD4575	1.51
74209H	LM750N	1.00	CD4576	1.51
74209H	LM750N	1.00	CD4577	1.51
74209H	LM750N	1.00	CD4578	1.51
74209H	LM750N	1.00	CD4579	1.51
74209H	LM750N	1.00	CD4580	1.51
74209H	LM750N	1.00	CD4581	1.51
74209H	LM750N	1.00	CD4582	1.51
74209H	LM750N	1.00	CD4583	1.51
74209H	LM750N	1.00	CD4584	1.51
74209H	LM750N	1.00	CD4585	1.51
74209H	LM750N	1.00	CD4586	1.51
74209H	LM750N	1.00	CD4587	1.51
74209H	LM750N	1.00	CD4588	1.51
74209H	LM750N	1.00	CD4589	1.51
74209H	LM750N	1.00	CD4590	1.51
74209H	LM750N	1.00	CD4591	1.51
74209H	LM750N	1.00	CD4592	1.51
74209H	LM750N	1.00	CD4593	1.51
74209H	LM750N	1.00	CD4594	1.51
74209H	LM750N	1.00	CD4595	1.51
74209H	LM750N	1.00	CD4596	1.51
74209H	LM750N	1.00	CD4597	1.51
74209H	LM750N	1.00	CD4598	1.51
74209H	LM750N	1.00	CD4599	1.51
74209H	LM750N	1.00	CD4600	1.51
74209H	LM750N	1.00	CD4601	1.51
74209H	LM750N	1.00	CD4602	1.51
74209H	LM750N	1.00	CD4603	1.51
74209H	LM750N	1.00	CD4604	1.51
74209H	LM750N	1.00	CD4605	1.51
74209H	LM750N	1.00	CD4606	1.51
74209H	LM750N	1.00	CD4607	1.51
74209H	LM750N	1.00	CD4608	1.51
74209H	LM750N	1.00	CD4609	1.51
74209H	LM750N	1.00	CD4610	1.51
74209H	LM750N	1.00	CD4611	1.51
74209H	LM750N	1.00	CD4612	1.51
74209H	LM750N	1.00	CD4613	1.51
74209H	LM750N	1.00	CD4614	1.51
74209H	LM750N	1.00	CD4615	1.51
74209H	LM750N	1.00	CD4616	1.51
74209H	LM750N	1.00	CD4617	1.51
74209H	LM750N	1.00	CD4618	1.51
74209H	LM750N	1.00	CD4619	1.51
74209H	LM750N	1.00	CD4620	1.51
74209H	LM750N	1.00	CD4621	1.51
74209H	LM750N	1.00	CD4622	1.51
74209H	LM750N	1.00	CD4623	1.51
74209H	LM750N	1.00	CD4624	1.51
74209H	LM750N	1.00	CD4625	1.51
74209H	LM750N	1.00	CD4626	1.51
74209H	LM750N	1.00	CD4627	1.51
74209H	LM750N	1.00	CD4628	1.51
74209H	LM750N	1.00	CD4629	1.51
74209H	LM750N	1.00	CD4630	1.51
74209H	LM750N	1.00	CD4631	1.51
74209H	LM750N	1.00	CD4632	1.51
7				



CALIFORNIA COMPUTER SYSTEMS

16K RAM BOARD. Fully buffered addressable in 4K blocks. IEEE standard for bank addressing 2114's PCB \$26.95
 Kit 450NSEC \$259.95
PT-1 PROTO BOARD. Over 2,600 holes 4" regulators. All S-100 buss functions labeled, gold fingers. PCB \$25.95
PT-2 PROTO BOARD. Similar to PT-1 except set-up to handle solder tail sockets. PCB \$25.95



FORMERLY CYBERCOM/SOLID STATE MUSIC.

PB-1 2708 & 2716 Programming Board with provisions for 4K or 8K EPROM. No external supplies require textool sockets. Kit \$124.95
CB-1 8080 Processor Board. 2K of PROM 256 BYTE RAM power on/rest Vector Jump Parallel port with status Kit \$119.00 PCB \$30.95
MB-6B Basic 8Kx8 ram uses 2102 type rams, S-100 buss. Kit 450 NSEC \$139.95 PCB \$26.95
MB-7 16Kx8, Static RAM uses μ P410 Protection, fully buffered Kit \$299.95
MB-8A 2708 EROM Board, S-100, 8Kx8 or 16Kx8 kit without PROMS \$75.00 PCB \$28.95
MB-9 4Kx8 RAM/PROM Board uses 2112 RAMS or 823129 PROM kit without RAMS or PROMS \$72.00
IO-2 S-100 8 bit parallel /IO port, 1/2 of boards is for kludging. Kit \$46.00 PCB \$26.95
IO-4 Two serial I/O ports with full handshaking 20/60 ma current loop: Two parallel I/O ports. Kit \$130.00 PCB \$26.95
VB-1B 64 x 16 video board, upper lower case Greek, composite and parallel video with software, S-100. Kit \$125.00 PCB \$26.95
Altair Compatible Mother Board, 11 x 11 1/2 x 1/4" Board only \$39.95. With 15 connectors \$94.95
Extended Board full size. Board only \$ 9.49
With connector \$13.45
SP-1 Synthesizer Board S-100 PCB \$42.95 KIT \$135.95



WAMECO INC.

FDC-1 FLOPPY CONTROLLER BOARD will drive shugart, pertek, remic 5" & 8" drives up to 8 drives, on board PROM with power boot up, will operate with CPM™ (not included). PCB \$42.95

FPB-1 Front Panel. IMSAI size, hex displays. Byte, or instruction single step. PCB \$47.50

MEM-1 8Kx8 fully buffered, S-100, uses 2102 type rams. PCB \$25.95

QM-12 MOTHER BOARD, 13 slot, terminated, S-100 board only \$34.95

CPU-1 8080A Processor board S-100 with 8 level vector interrupt PCB \$26.95

RTC-1 Realtime clock board. Two independent interrupts. Software programmable. PCB \$23.95

EPM-1 1702A 4K Eprom card PCB \$25.95

EPM-2 2708/2716 16K/32K EPROM CARD PCB \$25.95

QM-9 MOTHER BOARD, Short Version of QM-12, 9 Slots PCB \$30.95

MEM-2 16K x 8 Fully Buffered 2114 Board PCB \$26.95

8080A \$9.95	5101-8P \$ 8.40
8212 2.49	2114 (450 NS) low pwr 7.25
8214 4.49	2114 (250 NS) low pwr 7.99
8224 3.49	2102A-2L 1.50
2708 9.49	2102A-4L 1.20
5101-1P 6.90	4116 8/89.95



(415) 592-1800

P. O. Box 424 • San Carlos, California 94070

Please send for IC, Xistor and Computer parts list

OCT. SPECIAL SALE ON PREPAID ORDERS

(Charge cards not included on this offer)

WAMECO PWR SUPPLY AND TERMINATOR BOARD

12 Regulators for driving external equipment \$24.95
8Kx8RAM. Fully buffered 450 NSEC. 2.5 amp typical assembled parts may be unmarked or house numbered \$99.99

MIKOS PARTS ASSORTMENT

WITH WAMECO AND CYBERCOM PCBDS

MEM-2 with MIKOS #7 16K ram with L2114 450 NSEC \$249.95
MEM-2 with MIKOS #13 16K ram with L2114 250 NSEC \$279.95
MEM-1 with MIKOS #1 450 NSEC 8K RAM \$119.95
CPU-1 with MIKOS #2 8080A CPU \$94.95
MEM-1 with MIKOS #3 250 NSEC 8K RAM \$144.95
QM-12 with MIKOS #4 13 slot mother board \$89.95
RTC-1 with MIKOS #5 real time clock \$54.95
EMP-1 with MIKOS #10 4K 1702 less EPROMS \$49.95
EPM-2 with MIKOS #11 16-32K EPROMS less EPROMS \$59.95
QM-9 with MIKOS #12 9 slot mother board \$79.95
FPB-1 with MIKOS #14 all parts for front panel \$134.95

MIKOS PARTS ASSORTMENTS ARE ALL FACTORY PRIME PARTS. KITS INCLUDE ALL PARTS LISTED AS REQUIRED FOR THE COMPLETE KIT LESS PARTS LISTED. ALL SOCKETS INCLUDED.

VISA or MASTERCHARGE. Send account number, interbank number, expiration date and sign your order. Approx. postage will be added. Check or money order will be sent post paid in U.S. If you are not a regular customer, please use charge, cashier's check or postal money order. Otherwise there will be a two-week delay for checks to clear. Calif. residents add 6% tax. Money back 30 day guarantee. We cannot accept returned IC's that have been soldered to. Prices subject to change without notice. \$10 minimum order. \$1.50 service charge on orders less than \$10.00.

WAMECO

THE COMPLETE PC BOARD HOUSE EVERYTHING FOR THE S-100 BUSS

NEW! POWER SUPPLY AND TERMINATOR BOARD. PROVIDES UP TO 12 REGULATORS TO DRIVE ALL THOSE PERIPHERALS FROM THE COMPUTERS POWER SUPPLIES. TERMINATES THE MOTHER BOARD. SPECIAL OCT. PRICE \$28.95. AFTER OCT. 30 \$30.95 AT YOUR DEALER NOW!

FUTURE PRODUCTS: 80 CHARACTER VIDEO BOARD, IO BOARD WITH CASSETTE INTERFACE.

DEALER INQUIRIES INVITED, UNIVERSITY DISCOUNTS AVAILABLE AT YOUR LOCAL DEALER



WAMECO INC. 111 GLENN WAY #8, BELMONT, CA 94002 (415) 592-6141

16K EPROM CARD-S 100 BUSS

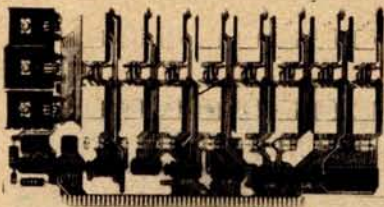

\$59.95
KIT

OUR
BEST
SELLING
KIT!

USES 2708's!

Thousands of personal and business systems around the world use this board with complete satisfaction. Puts 16K of software on line at **ALL TIMES!** Kit features a top quality soldermasked and silk-screened PC board and first run parts and sockets. All parts (except 2708's) are included. Any number of EPROM locations may be disabled to avoid any memory conflicts. Fully buffered and has WAIT STATE capabilities.

OUR 450NS 2708'S
ARE \$8.95 EA. WITH
PURCHASE OF KIT

ASSEMBLED
AND FULLY TESTED
ADD \$25

8K LOW POWER RAM KIT-S 100 BUSS SALE

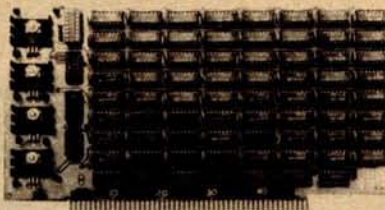

PRICE
CUT!

\$119.50
KIT

2 FOR \$225

(450 NS RAMS!)

Thousands of computer systems rely on this rugged, work horse, RAM board. Designed for error-free, NO HASSLE, systems use.

KIT FEATURES:

1. Doubled sided PC Board with solder mask and silk screen layout. Gold plated contact fingers.
2. All sockets included.
3. Fully buffered on all address and data lines.
4. Phantom is jumper selectable to pin 67.
5. FOUR 7805 regulators are provided on card.

Blank PC Board w/Documentation
\$29.95

Low Profile Socket Set...**13.50**

Support IC's (TTL & Regulators)
\$9.75

Bypass CAP's (Disc & Tantalums)
\$4.50

ASSEMBLED AND FULLY
BURNED IN ADD \$30

16K STATIC RAM KIT-S 100 BUSS

PRICE CUT!

\$279 KIT

FOR 250NS
ADD \$20

FULLY
STATIC, AT
DYNAMIC PRICES

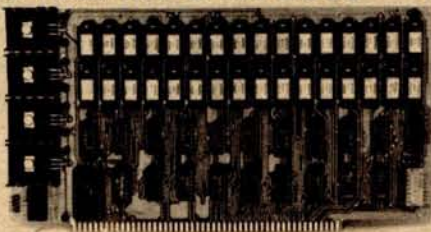

WHY THE 2114 RAM CHIP?

We feel the 2114 will be the next industry standard RAM chip (like the 2102 was). This means price, availability, and quality will all be good! Next, the 2114 is FULLY STATIC! We feel this is the ONLY way to go on the S-100 Bus! We've all heard the HORROR stories about some Dynamic Ram Boards having trouble with DMA and FLOPPY DISC DRIVES. Who needs these kinds of problems? And finally, even among other 4K Static RAM's the 2114 stands out! Not all 4K static Rams are created equal! Some of the other 4K's have clocked chip enable lines and various timing windows just as critical as Dynamic RAM's. Some of our competitor's 16K boards use these "tricky" devices. But not us! The 2114 is the ONLY logical choice for a trouble-free, straightforward design.

KIT FEATURES:

1. Addressable as four separate 4K Blocks.
2. ON BOARD BANK SELECT circuitry. (Cromemco Standard). Allows up to 512K on line!
3. Uses 2114 (450NS) 4K Static Rams.
4. ON BOARD SELECTABLE WAIT STATES.
5. Double sided PC Board, with solder mask and silk screened layout. Gold plated contact fingers.
6. All address and data lines fully buffered.
7. Kit includes ALL parts and sockets.
8. PHANTOM is jumpered to PIN 67.
9. LOW POWER: under 2 amps TYPICAL from the +6 Volt Bus.
10. Blank PC Board can be populated as any multiple of 4K.

BLANK PC BOARD W/DATA—\$33

LOW PROFILE SOCKET SET—\$12
SUPPORT IC'S & CAPS—\$19.95

ASSEMBLED & TESTED—ADD \$30
2114 RAM'S—8 FOR \$69.95

16K STATIC RAM SS-50 BUSS

\$295 KIT

FULLY STATIC
AT DYNAMIC PRICES

KIT FEATURES:

1. Addressable on 16K Boundaries
2. Uses 2114 Static Ram
3. Runs at Full Speed
4. Double sided PC Board. Solder mask and silk screened layout. Gold fingers.
5. All Parts and Sockets included
6. Low Power: Under 2 Amps Typical

FOR SWTPC
6800 BUSS!

ASSEMBLED AND
TESTED - \$30

BLANK PC BOARD—\$33

COMPLETE SOCKET SET—\$12
SUPPORT IC'S AND CAPS—\$19.95

S-100 Z80 CPU CARD

ASSEMBLED AND TESTED! READY TO USE! Over 3 years of design efforts were required to produce a TRUE S-100 Z80 CPU at a genuinely bargain price! **4 MHZ! \$159.95**

FEATURES:

- * 2 or 4 MHZ Operation.
- * Generates MWRITE, so no front panel required.
- * Jump on reset capability
- * 8080 Signals emulated for S-100 compatibility.
- * Top Quality PCB, Silk Screened, Solder Masked, Gold Plated Contact Fingers.

Perfect For
OEM's

Z-80 PROGRAMMING MANUAL

By MOSTEK, or ZILOG. The most detailed explanation ever on the working of the Z-80 CPU CHIPS. At least one full page on each of the 158 Z-80 instructions. A MUST reference manual for any user of the Z-80. 300 pages. Just off the press. **\$12.95**

PROC. TECH. QUITS THE MICROPROCESSOR BUSINESS!

FACTORY CLOSE OUT - SPECIAL PURCHASE!

#16KRA

16K S-100 Dynamic Ram Board - \$149.95

ORIGINALLY PRICED AT \$429 each!

We purchased the remaining inventory of PT's popular 16K Ram Board when they recently closed their plant. Don't miss the boat! These are brand new, fully tested, ASSEMBLED and ready to go. All are sold with our standard 90 day limited warranty!!

72 Page Full Manual, Included Free!

NOT ASSOCIATED WITH DIGITAL RESEARCH OF CALIFORNIA, THE SUPPLIERS OF CPM SOFTWARE.

Digital Research: Computers
(OF TEXAS)

P.O. Box 401565 • GARLAND, TEXAS 75040 • (214) 494-1505

TERMS: Add 50¢ postage, we pay balance. Orders under \$15 add 75¢ handling. No C.O.D. We accept Visa, MasterCard, and American Express cards. Tex. Res. add 5% Tax. Foreign orders (except Canada add 20% P & H. 90 Day Money Back Guarantee on all items.

What's New?

PERIPHERALS

Full Duplex Synchronous Intelligent Modem

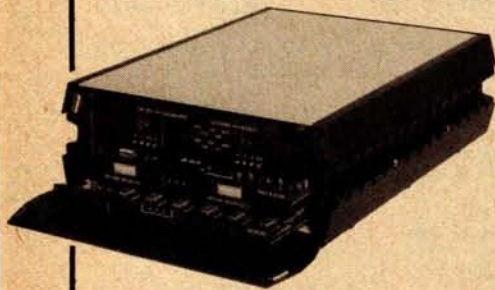

SuperModem transmits data thousands of miles at 9600 bits per second (bps) over unconditioned voice band data channels. By using an unconventionally low data rate it achieves a substantially higher tolerance to the transient noise-hits inherent in communication networks. It uses a transmitter that simultaneously generates a large number of individual carriers, modulating each to represent only a portion of the total data stream. The modem's receiver demodulates each carrier independently, and its data is combined with that from the other carriers to reconstruct the original data stream.

Three compact plug-in modules make up SuperModem: the program memory, 24-bit data processor, and the I/O (input/output) control. The program module includes a program built around algorithms which perform real-time analysis of the received signal. The 24-bit data processor uses pipeline architecture to attain an operating speed of 10 million instructions per second. It also is used to analyze circuit parameters while on-line and to perform diagnostic routines. Front panel controls provide the operator with mode selection, and enable configuration of the channel status indicators and the 3 digit diagnostic display.

For further information, contact Gandalf Data Inc, 1019 S Noel, Wheeling IL 60090.

Circle 589 on inquiry card.

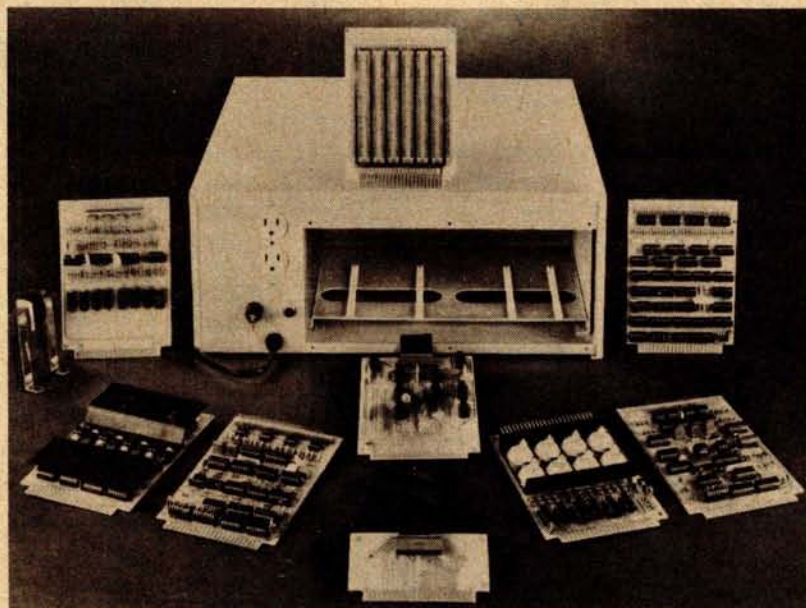

General Purpose Data Acquisition and Process Control System

The Real World Interface System is a general purpose data-acquisition and process control system designed for use with mini and microcomputers. It features many different plug-in modules which give the user the flexibility and power to configure the system according to the user's needs. Applications include environmental control, peak demand limiting, robotics, and automated assembly line testing.

The unit has its own cabinet which includes a power supply, card cage, and motherboard with slots for up to 12 plug-ins. Each plug-in card has at least 8

channels of input or output (except for a maximum of 4 channels on the current probe), and some have 16 or even 32 channels.

All plug-ins can be purchased in either kit form or assembled and tested. The modules range in price from \$65 a kit (\$79.50 assembled) for the 8 channel DC controller card to \$125 a kit (\$150 assembled) for the 8 channel AC controller card. A cabinet, complete with motherboard, power supply, and parallel processor interface, is \$299 for the kit (\$360 assembled). For further information, contact General Computer Technology, 400 S Lipan, Suite 2, Denver CO 80223.

Circle 590 on inquiry card.

Voice Synthesizer for the TRS-80 Computer

The TRS-80 Voice Synthesizer is an accessory for Radio Shack's TRS-80 microcomputer system. It translates a computer output into recognizable, intelligible speech. The synthesizer

includes a volume control, built-in speaker and cable assembly that permits easy plug-in connection to the TRS-80. Programming the TRS-80 for speech is done in BASIC. About 60 phonemes, representing units of speech,

can be entered via the computer keyboard. This will even enable the computer to speak in foreign languages or with an accent, by integrating the various phonemes to produce the desired sounds. The voice synthesizer is especially useful in the field of education where it is used to supplement the displayed video information in a variety of learning situations such as spelling, reading, language arts, and mathematics.

The Radio Shack TRS-80 Voice Synthesizer is priced at \$399 complete with detailed instruction manual and demonstration cassette. For further information, contact Radio Shack, 1300 One Tandy Ctr, Forth Worth TX 76102.

Circle 591 on inquiry card.

FLOPPY SYSTEMS



8" Siemens FDD120-8
All Siemens options included in this drive may be configured hard or soft and single or double density. We find this to be an extremely reliable drive. **\$399.00**



5 1/4" BASF Magical Miniature Mini drive only 2/3 the size of others is reliable and durable and quickly gaining in popularity with our customers. Single or dual density fast access times **\$274.00**



Tarbell Controller may be re-configured to control 5 1/4" drives and includes short cable for one drive. **KIT \$179.00, ASM \$265,** but only **\$219** with purch. of 2 drives.



Cable Kits For 8" Drives with 10' 50 cond. cable and connectors. Also power cable and connectors. Flat cable assem if you wish. For one drive **27.50,** two **33.95,** three **38.95**

Cable Kits for 5 1/4" Drives as above, but 34 cond. For one drive **24.95,** two **29.95.**



"Power One" Model CP206 Power Supply adequate for at least two drives, 2.8A/24V 2.5A/5V, 0.5A/-5V beautiful quality. **\$99.00**



CABINETS for FDD120 and 801R drives, or CP206 supply. Matte finish in mar resistant black epoxy paint and stacking design **29.95**

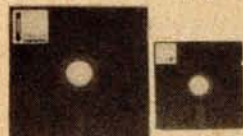

DISKETTES
(3M, MRX, BASF, Georgia Magnetics, & Victor Borge)
8" **\$39.95/10**
5 1/4" **\$29.95/10**

32K / 16K Static RAM, 4MHz.

(Showing Amazing Similarity to Tarbell's unit)
(16K Shown in photo)

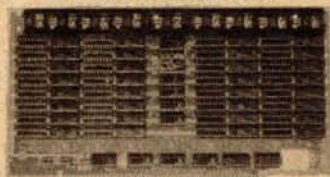

32K - \$549.00 16K - \$349.00

"BACK TO SCHOOL" KEYBOARD SPECIAL



CHERRY "PRO" Keyboard \$119.00
Streamlined Custom Enclosure \$34.95
BOTH ONLY \$124.95 !!!!!!!

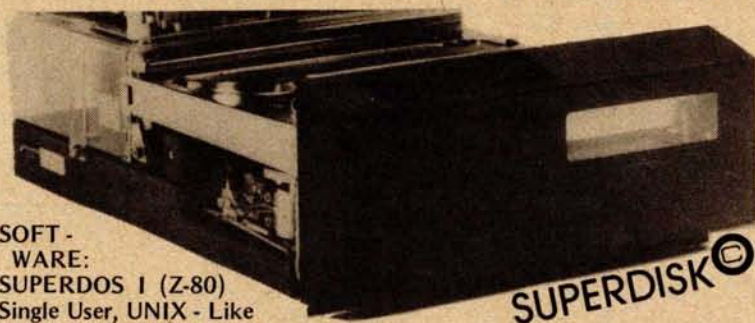

10MByte DRIVE \$3300

S - 100 DMA CONTROL \$495

POWER UNIT \$395.00

SOFTWARE:
SUPERDOS 1 (Z-80)
Single User, UNIX - Like File System, AND Totally Upward Compatable From "XX/X"
(What did you say, Digital Research??)

PS: SUPERDOS-1 runs on the TRS-80, and can transform it from a toy computer to a real business machine !!!

For the first time in something like 10 years, a new STANDARD in removable media has evolved. Selected by Datapoint, and others who have not yet announced, this drive is beautifully simple and easy, if not trivial to maintain. 920kBy/sec, transfer rate, 3600 RPM 39 lbs and only 125 Watts.

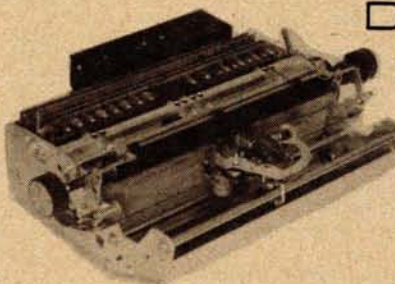

Daisy Wheel Printers

Qume Sprint 3\45

PRINTER (factory warr.) \$1199.00
POWER SUPPLY (Boschert) \$349.00
(shown mounted on rear of printer)

COMBINATION SPECIAL \$1499.00

DATA DISPLAY MONITORS

Used 12" Sylvania monitors. Composite Video, 15 MHz, 120VAC. Rebuilt with NEW P39 anti-glare tube \$119.00
New P4, 109.00, used P4 79.00.



"OEM STYLE" as above, will fit any case. (Both versions serviced by qualified tech). Identical to above but subtract **\$12.00**

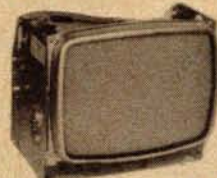

Doppler Motion Sensor Intrusion Detector

Extremely effective microwave motion detector for detecting unwanted visitors. Ignores mice and other non-larcenous creatures. Operates on 12VDC or from small transformer supplied. Output is relay closure for alarm control interface, or to switch on lights annunciators. Will operate THROUGH door of closet or thin wall. Best application seems to be to turn on outside lights to help invited guests, and to intimidate unwanted ones. **\$159.00**
Water Repellent Cover **\$24.95**

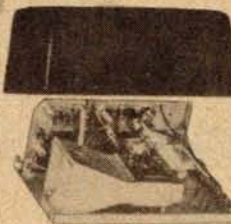

New!

Electrolabs

POB 6721, Stanford, CA 94305
415-321-5601 800-227-8266
Telex: 345567 (Electrolab Pla)
Visa MC Am. Exp.

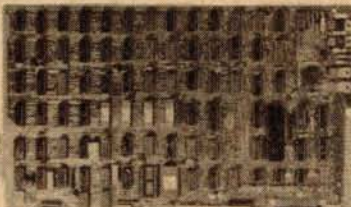

ESAT 200B

BI-LINGUAL 80x24 COMMUNICATING TERMINAL

Scrolling, full cursor, bell, 8x8 matrix, 110 - 19,200 baud, Dual Font Applications. Arabic & Hebrew, Multilingual Data Entry Forms Drawing, Music, & Switchyards. **\$349.00**



SOCKET SPECIAL



"Won't Let Go"

Low Profile

Solder Tail

1 CENT/ Pin !! (0.75/1000's)

8 14 16 18 20 22 24 28 40

We've Moved!

Pacific Office Systems — formerly at 2600 El Camino Real, Palo Alto, CA 94306
New Address: 918 INDUSTRIAL AVENUE, PALO ALTO, CA 94303
New Telephone: (415) 493-7455

PRINTER TERMINALS



- **ASCII SELECTRIC PRINTER/TYPEWRITER:** Why settle for less than letter-quality printout from your computer? IBM Model 725 can be used as off-line typewriter or on-line printer. Complete with solenoids, power supply, case and ASCII interface card (TTL to CPU parallel port). Interface includes programmable ASCII translation table on EPROM with up to 8 tables for use with various type spheres. Feedback signals on completion of each print cycle insures fastest printing speed (15 cps), cleaned and adjusted.
 Price: programmed w/3 translation tables (one type sphere) \$795.00
- **SELECTRIC I/O TERMINALS** by GTE/Information Systems). Both ASCII & IBM code versions with micro-computer interface software & hardware (RS-232 connector). Cassette drive models permit up to 2400 baud data transfer rate as well as off-line data storage, use as memory typewriter, & use as data entry device for office personnel familiar with Selectric typewriters but not computers. Wide-carriage, interchangeable type spheres; optional built-in modem. All units cleaned, adjusted & warranted.
 Model 5541 (IBM Correspondence code) \$ 795.00
 Model 5550 (corres. code, built-in cassette drive) . . . \$1195.00
 Model 5560 (ASCII code, built-in cassette drive) . . . \$1295.00

- **"DAISY-WHEEL" I/O TERMINALS:** Both DIABLO and QUME versions of the industry standard "daisy-wheel" printing terminals are available. All have keyboards w/full ASCII character set & RS-232 serial interface. Models in stock usually include Diablo 1550, DTC 300 & 300Q, GenCom 300 & 300Q, and others. Prices for refurbished units range from \$1800.00 to \$2400.00
- **DIABLO HYTYPE I Model 1200 PRINTER MECHANISM:** Used, complete and tested. Requires power supply, case & mCPU interface. Tested: . . . \$750.00
 - 6' Ribbon cable and connector
 - for printer Main Logic PCB \$ 10.00
 - "As-is" spare printer PCB's for parts (Logic, Heat Sink, Control): each \$ 20.00
 - New Pin-feed Platen (14")
 - \$50 if bought w/printer; separately . . . \$100.00

TAPE DRIVES & CONTROLLERS



- **POS-100 NRZ1 TAPE DRIVE CONTROLLER/FORMATTER:** Designed as interface between S-100 bus mCPU and 9-track, 800 BPI, NRZ1 tape drive. Allows microcomputerist to read and write IBM-compatible 1/2" mag tapes. Software provided for 8080 or Z-80 systems. Requires modification for drives of various mfrs. Std. version: 2 MHz/ 8080/Z-80 CPU for use with 12"/sec. PERTEC-style Tape Drive.
 Price: (Includes S-100 card, controller card, 10' cable, software listing) \$750.00
- **NRZ1 TAPE DRIVE** by CIPHER Data Products: Full size PERTEC-style 800 BPI drive model 1008XX; 2400' Tape, 9 track, 25 to 37 ips, used, refurbished. Wt. approx. 120 lb. Price: \$1500.00
- **CONVERT 15" IBM OFFICE SELECTRIC TO I/O TYPEWRITER:** Kit includes assembled solenoids, switches, wire harness, magnet driver PCB plus instructions for installation and mCPU interface . . . \$200.00
- **DIGITAL CASSETTE DRIVE** (from GTE/IS Terminal): 1800 baud, 6"/sec; AC motor; fwd/rewind circuitry plus tape head, no read/write electronics . . . \$25.00
- **FORMS TRACTORS, Moore** Variable width "Form A-Liner" for print terminals:
 - a) Model 565P for 15" Carriage IBM Selectrics (used) \$75.00
 - b) Model K81 for QUME or DIABLO Hytype I or II printers (new) \$90.00
- **POWER SUPPLIES** for Disk Drive, mCPU, tested under load shown:
 - No. 519 (w/Jan & AC cord): +5 V reg. +12V reg., +24V, @4A (10 lb.) \$39.95

MODEMS



- **POS 103/202 "MIX or MATCH" MODEM:** BELL 103 and/or BELL 202 FREQUENCIES: Unique POS control design permits use in one housing of both Bell-compatible 103 (0-300 baud) and 202 (0-1200 baud) modem modules originally made by VADIC Corp. for a telephone company subsidiary. FEATURES: RS-232 serial interface, auto-answer, auto-dial, LED display, telephone line interface via acoustic coupler, manual DAA, or auto-answer DAA (sold separately). FULLY ADJUSTED; no special tools required. 3,000 mile range over standard dial-up telephone lines.
 - POS 103 MODEM \$179.95
 - POS 202 MODEM \$249.95
 - POS 202 MODEM (Auto-Answer) \$279.95
 - POS 103/202 MODEM \$399.95

NO RISK!! 15 DAY APPROVAL ON ALL MAIL-ORDERS

Full documentation included PLUS interface instructions where indicated. All equipment is shipped insured FOB Palo Alto within 14 days after check clears or COD order is received. Prices may change without notice. Call or write for details, quantity prices, catalog. 15 day return privilege PLUS 90 day no charge replacement of defective parts. All orders shipped from stock. No back orders, no substitutions. Master Charge and VISA accepted.



EXCITING MAIL ORDER DISCOUNTS



NOVATION CAT ACOUSTIC MODEM



- ANSWER, ORIGINATE
- 300 BAUD
- BELL 103
- LOW PROFILE DESIGN

\$179⁰⁰

TI 810 PRINTER



- 150 CHARACTERS PER SECOND
- RS 232C SERIAL INTERFACE
- ADJUSTABLE FORMS TRACTOR

\$1,595

• OPTIONAL LOWER CASE ADD \$90.00

SORCERER™ BY EXIDY \$895



- Z-80 PROCESSOR • 30-64 DISPLAY
- FULL SIZE ASCII KEYBOARD
- USER DEFINABLE CHARACTERS
- INTERCHANGEABLE ROM PACS
- RESIDENT 4K MONITOR ROM
- SERIAL AND PARALLEL I/O
- COMPLETE OPERATOR'S MANUAL
- DUAL CASSETTE I/O

8k \$895 • 16k \$1,050 • 32k \$1,150

SOROC IQ 120



- SERIAL RS232C
- FULL ASCII UPPER/LOWER CASE
- NUMERIC KEYPAD CURSER KEYS
- SCREEN CONTROL & PROTECTED FIELDS

\$775⁰⁰

\$100 EXPANSION UNIT

\$299⁰⁰

LEEDEX VIDEO 100



- 12" BLACK & WHITE MONITOR
- COMPOSITE VIDEO INPUT

\$129⁰⁰

Apple II 16K \$995⁰⁰



- COLOR • GRAPHICS • SOUND
- APPLE DISK II \$495.00 INCLUDES CONTROLLER

16K MEMORY KIT

UPGRADES TRS-80, APPLE, EXIDY SORCERER PET & SD SALES EXPANDORAM, ETC. 8 PRIME-TESTED 4116 DYNAMIC RAM CHIPS FROM A MAJOR MANUFACTURER. INSTALLATION INSTRUCTIONS INCLUDED. **\$65⁰⁰**

IC'S

- 411K 4K \$2.95
- 4116 16K \$8.25
- 2708 EPROM \$8.50
- 2718 5V EPROM \$45.00
- MANY MORE IC'S AVAILABLE
- CALL OR WRITE FOR PRICE LIST

• TO ORDER •

PHONE ORDERS INVITED. PERSONAL CHECK OR MONEY ORDER. ALL ORDERS ARE SHIPPED FREIGHT COLLECT IN FACTORY CARTON WITH MANUFACTURER'S WARRANTY. CALL FORNIA RESIDENTS ADD 6% SALES TAX. ALL EQUIPMENT SUBJECT TO AVAILABILITY & PRICE CHANGE WITHOUT NOTICE.



COMPUTER SPECIALTIES

**6363 EL CAJON BLVD., SUITE 205
 SAN DIEGO, CA 92115 • (714) 579-0330**



computer products, inc.

11542-1 KNOTT STREET
GARDEN GROVE, CALIFORNIA 92641
(714) 891-2663

MICROBYTE Z80/I-O

- A complete single board Z80A CPU and serial/parallel I/O system
- Fully S-100 Bus compatible, IMSAI, ALTAIR
- Z80A CPU (4 MHz version of the Z80)
- 158 instructions — superset of and upward compatible from the 8080's 78 instructions
- Provision for up to 4K on board monitor program using 1K (2708), 2K (2716), 4K 2732
- On board EPROM can be hardware and/or software deselected
- 2 MHz or 4 MHz operation is switch selectable
- 0 or 1 wait state for all cycles is switch selectable
- 2 RS-232C serial ports with 8251 USARTs
- Serial baud rates switch selectable
- 24 programmable parallel I/O lines (uses 8255)

- Gold Contacts for higher reliability
- Power requirements: +8V @ 800mA, +16V, @ 86mA, - 16V @ 100mA
- Operating temperature 0°-55°C
- Will operate with or without IMSAI/ALTAIR front panel
- Low power shottky tri-state buffers on all address and data lines
- Fully warranted for 120 days from date of shipment



\$325.⁰⁰

IMSAI CONN.

100 PIN-SOLDERTAIL
GOLD CONTACTS

\$3.⁰⁰ each or 10/2.60 each

8251
PROGRAMMABLE/U-ART
TESTED @ 4 MHZ
\$5.⁰⁰ each

TRS - 80

Floppy disk drive with cabinet & pwr. supply compatible with Radio Shack interface. Assembled & tested with 1 yr. warranty on parts & labor.



\$385.⁰⁰

Mfg. by Lobo Drive

Interface Cable Available

SPECIAL

.1 @ 12 VOLTS
CERAMIC CAP
10¢ each
or
100 / \$9.⁰⁰

MICROBYTE 16K STATIC RAM BOARD

- Fully S100 Bus Compatible, IMSAI, SOL, ALTAIR, ALPHA MICRO
- Uses National's Low Power 5257 4K x 1 Static Rams
- 2 MHz or 4 MHz operation
- On board single 5 amp regulator
- Thermally designed heat sink (board operating temperature 0° - 70°C)
- Inputs fully low power Shottky Schmitt Trigger buffered on all address and data lines
- Phantom is jumper selectable to pin 67
- Each 4K bank addressable to any 4K slot with in a 64K boundary.
- 4K hardware or software selectable
- Selectable port address
- 4K banks can be selected or disabled on power on clear or reset

- Will operate with or without front panel
- Compatible with ALPHA MICRO, with extended memory management for selection beyond 64K
- No DMA restriction
- Low power consumption 1.3 amp
- Fully warranted for 120 days from date of shipment
- Extended addressing up to 1 megabyte of addressable ram



450 NS \$320.⁰⁰
300 NS \$340.⁰⁰

SHUGART 801-Disk Drive

WITH CABINET & POWER SUPPLY
ASSEMBLED & TESTED
1 YR PARTS & LABOR

Mfg. by Lobo Drive

\$585.⁰⁰

Dual Cabinet & Drives Available

2708's
LOW POWER
450 NS.
\$8.⁷⁵ each
8 for \$66.⁰⁰

MICROBYTE 32K STATIC RAM BOARD

- Fully S100 Bus Compatible, IMSAI, SOL, ALTAIR, ALPHA MICRO
- Uses National's Low Power 5257 4K x 1 Static Rams
- 2 MHz or 4 MHz operation
- On board single 5 amp regulator
- Thermally designed heat sink (board operating temperature 0° - 70°C)
- Inputs fully low power Shottky Schmitt Trigger buffered on all address and data lines
- Phantom is jumper selectable to pin 67
- Each 4K bank addressable to any 4K slot with in a 64K boundary.
- 4K hardware or software selectable
- One on board 8-bit output port enables or disables the 32K in 4K blocks
- Selectable port address
- 4K banks can be selected or disabled on power on clear or reset

- Will operate with or without front panel
- Compatible with ALPHA MICRO, with extended memory management for selection beyond 64K
- No DMA restriction
- Low power consumption 2.3 - 2.5 amps
- Fully warranted for 120 days from date of shipment.
- Extended addressing up to 1 megabyte of addressable ram



450 NS \$620.⁰⁰
300 NS \$650.⁰⁰

SHUGART SA400

DISK DRIVE INCLUDES CABINET, NO PWR SUPPLY, CUTOUPS FOR SWITCH, FUSE, & INTERFACE CABLE

Mfg. by Lobo Drive

\$325.⁰⁰

2716
5 VOLT ONLY
LOW POWER
450 ns
\$40.⁰⁰

MICROBYTE MOTHERBOARD

- Active Diode termination
- Slot for IMSAI front panel
- Terminal block connection for easy hook-up

- Extra wide ground plane
- Silk screen and solder mask
- Assembled and tested

9 slot kit \$70.⁰⁰ A&T \$100.⁰⁰
20 slot kit \$125.⁰⁰ A&T \$155.⁰⁰
Bare Board 9 slot \$30.⁰⁰ 20 slot \$50.⁰⁰

SCANBE / RN SOCKETS — LO PROFILE

	1-24	25-99	100-499	500 up
14 PIN	.16	.15	.14	.12
16 PIN	.17	.16	.15	.14
18 PIN	.20	.19	.18	.16
20 PIN	.29	.28	.26	.25
24 PIN	.34	.32	.30	.28
40 PIN	.60	.58	.56	.52

REGULATORS

	1-9	10-49	50up
320 T-5	1.25	1.15	1.05
320 T-12	1.00	.90	.85
340 T-5	.75	.70	.65
340 T-12	.75	.70	.65
78 H05	6.00	5.70	5.40

MICROBYTE DISK CONTROLLER

- IBM 3740 Soft Secteded Compatible
- Z80 or 8080 compatible on S-100 Bus
- Single density runs both mini and full size drives, runs CPM, on Shugart, Perci, Memorex etc.
- Selectable port/address
- On board 2708/2716 for bootstrap or monitor program
- No hardware jumpers, uses plug in modules for different drives
- Uses 1771B-01 controller chip
- Assembled and tested
- Specify disk drive used when ordering by mail



\$225.⁰⁰

NEW PRODUCTS

8086 — CPU BOARD
8088 — CPU BOARD
Double Density Controller

CALL OR WRITE
FOR DEALER INFO

CABLE ASSEMBLY
for 8" disk drives
(2) 50 PIN CARD -
EDGE CONNECTORS
ON 4ft. RIBBON
CABLE
\$20.⁰⁰ ea.
extra conn. \$7.⁰⁰ ea.

ORDERING INFORMATION:

Name, Address, Phone
Ship by: UPS or P.P.
Shipping Charge: Add \$2.50 up to 5 lbs., all excess shipping charges will be refunded. Credit cards will be charged appropriate freight.

TERMS:

We accept cash, check, money orders, Visa, and Master Charge cards. (U.S. Funds Only).
COD's: on approval only
Open Acct's: companies may inquire for net terms.
Tax: add 6% for Calif. residents only

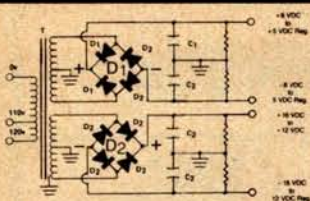

BUILD YOUR OWN LOW COST MICRO-COMPUTER POWER SUPPLIES FOR S-100 BUS, FLOPPY DISCS, ETC.

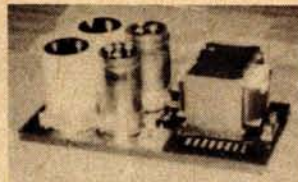

POWER TRANSFORMERS (WITH MOUNTING BRACKETS)

ITEM NO.	USED IN KIT NO.	PRI. WINDING TAPS	SECONDARY WINDING OUTPUTS			SIZE W x D x H	UNIT PRICE
			2x8 Vac	2x14 Vac	2x24 Vac		
T ₁	1	0V, 110V, 120V	2x7.5A	2x2.5A	—	3 3/4" x 3 3/8" x 3 1/8"	19.95
T ₂	2	0V, 110V, 120V	2x12.5A	2x3.5A	—	3 3/4" x 4 3/8" x 3 1/8"	25.95
T ₃	3	0V, 110V, 120V	2x9A	2x2.5A	2x2.5A	3 3/4" x 4 3/8" x 3 1/8"	27.95
T ₄	4	0V, 110V, 120V	2x4.5A	—	2x4.5A	3 3/4" x 3 3/8" x 3 1/8"	19.95

POWER SUPPLY KITS (OPEN FRAME WITH BASE PLATE, 3 HRS. ASSY. TIME)

ITEM	USED FOR	Voltage Outputs					SIZE W x D x H	UNIT PRICE
		@+8 Vdc	@-8 Vd:	@+16 Vdc	@-16 Vdc	@+28 Vdc		
KIT 1	18 CARDS SOURCE	15A	—	2.5A	2.5A	—	12" x 6" x 4 7/8"	46.95
KIT 2	SYSTEM SOURCE	25A	—	3A	3A	—	12" x 6" x 4 7/8"	54.95
KIT 3	DISC SYSTEM	18A	1A	2A	2A	4A	14" x 6" x 4 7/8"	62.95
KIT 4	DISC SOURCE	8A	1A	—	—	8A	10" x 6" x 4 7/8"	44.95

EACH KIT INCLUDES: TRANSFORMER, CAPACITORS, RESIS., BRIDGE RECTIFIERS, FUSE & HOLDER, TERMINAL BLOCK, BASE PLATE, MOUNTING PARTS AND INSTRUCTIONS.

REGULATED POWER SUPPLY "R2" ASSY. & TESTED, OPEN FRAME, SIZE: 9" (W) x 5" (D) x 5" (H) \$69.95

SPECS: +5V +1%, @ 5A, +24V, +1%, @ 5A. OVERCURRENT PROTECTION AND +5% ADJ. FOR BOTH VOLTAGES.

REMARK: IDEAL FOR ROCKWELL AIM-65 MICROCOMPUTER. ALSO -5V. @ 1A OPTIONAL, \$5.00 ADDITIONAL.

SHIPPING FOR EACH TRANSFORMER: \$4.75. FOR EACH POWER SUPPLY: \$5.00 IN CALIF. \$7.00 IN OTHER STATES. CALIF. RESIDENTS ADD 6% SALES TAX. OEM WELCOME.

SUNNY INTERNATIONAL
(TRANSFORMERS MANUFACTURER)
Telephone: (213) 633-8327

STORE:
7245 E. ALONDRA BLVD.
PARAMOUNT, CA 90723
STORE HOURS: 9 AM-6 PM



MAIL ORDER:
P.O. BOX 4296
TORRANCE, CA 90510



AIM 65

AIM 65 is fully assembled, tested and warranted. With the addition of a low cost, readily available power supply, it's ready to start working for you. It has an addressing capability up to 65K bytes, and comes with a user-dedicated 1K or 4K RAM.

- Thermal Printer
- Full-Size Alphanumeric Keyboard
- True Alphanumeric Display
- Proven R6500 Microcomputer System Devices
- Built-In Expansion Capability
- TTY and Audio Cassette Interfaces
- ROM Resident Advanced Interactive Monitor
- Advanced Interactive Monitor Commands

PRICE: \$375.00 (1K RAM) \$369.00

Plus \$4.00 UPS (shipped in U.S. must give *street* address), \$10 parcel post to APO's, FPO's, Alaska, Hawaii, Canada, \$25 air mail to all other countries

We manufacture a complete line of high quality expansion boards. Use reader service card to be added to our mailing list, or U.S. residents send \$1.00 (International send \$3.00 U.S.) for airmail delivery of our complete catalog.

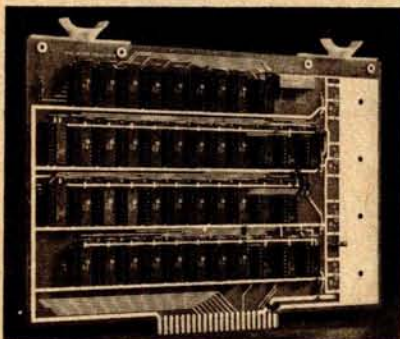

VAK-4 16K STATIC RAM BOARD

- Designed specifically for use with the AIM-65, SYM-1, and KIM-1 microcomputers
- Two separately addressable 8K-blocks with write protect.
- Designed for use with the VAK-1 or KIM-4* motherboards
- Has provisions for mounting regulators for use with an unregulated power supply
- Made with 1st quality 2114 static ram chips
- All IC's are socketed
- Completely assembled, burned-in, and tested

We manufacture a complete line of high quality expansion boards. Use reader service card to be added to our mailing list, or U.S. residents send \$1.00 (International send \$3.00 U.S.) for airmail delivery of our complete catalog.

*Product of MOS Technology

VAK-4 DUAL 8K-RAM ~~\$370.00~~ \$325.00
VAK-2 8K-RAM (1/2 populated) \$239.00



2967 W. Fairmount Avenue • Phoenix, AZ 85017 • (602) 265-7564

What's New?

SOFTWARE

Pascal for 6800 Processor

A new Pascal compiler is available which runs under the TSC Flex Version 1.0 operating system on a SwTPC 6800 system (or equivalent) with sufficient hardware. It is possible to compile and run Pascal programs in as little as 16 K bytes using a 5-inch floppy disk. The run-time system interfaces fully with Flex, permits user device handling, and includes a paging facility which is invoked automatically if there is sufficient real memory for a large program.

In a 32 K byte, 1 MHz clock frequency system with dual floppy disks, Pascal programs can be compiled at over 80 lines per minute. With 20 K bytes, compilation is at 35 lines per minute, under the paging mode of execution. The P-code generated by the compiler is compact and efficient, so that programs execute much faster than is possible with conventional interpreters.

The compiler is written in the subset of Pascal which it supports, and includes files, procedures, functions, recursion, sets, arrays, and CASE statements as

well as the looping and branching constructs.

Release Version 1.0 of the Pascal compiler and P-code interpreter and run-time system are provided on a Flex Version 1.0 format 5-inch floppy disk. User documentation, useful utilities, and specimen programs are also supplied. Contact Lucidata (Pascal Div), Oosteinde 223, Voorburg 2271 EG (ZH), NETHERLANDS.

Circle 620 on inquiry card.

C Compiler for 8080 Microcomputer

A full C compiler for 8080-based microcomputer systems is available from Whitesmiths Ltd, 127 E 59th St, New York NY 10022. Provided with the compiler are a complete set of runtime support routines; the Whitesmiths Portable C Library, an interface library for operation of C under either CP/M or ISIS-II operating systems; and a translator for the narrative assembly language A-Natural.

The 8080 compiler is currently

available as a cross-compiler running on the PDP-11 under UNIX, RSX-11M, RT-11, RSTS/E, and IAS operating systems. Operating in three sequential passes, it produces A-Natural code, which is then translated to assembly language that is compatible with Intel's asm80 and Microsoft's Macro-80. Source code may also be written in A-Natural for processing by the same translator.

Owners of the Whitesmiths PDP-11 C Compiler will find that the 8080 implementation is highly compatible. Programs written using only the Portable C Library should run unchanged on the 8080, permitting extensive code checking on the PDP-11.

A standard cross-compiler package is available at a price of \$700 for object code to be run on a single processor. This package includes the C compiler and PDP-11 support routines, the A-Natural translator, and the runtime library for use on a single 8080 processor. Use of the minimal machine-interface library on additional microcomputers is available for as little as \$10 per processor.

Circle 621 on inquiry card.

SAVE THE WHALE

The Fin Whale is the world's greatest long-distance communicator.

Scientists believe that loud, deep-tone, low-frequency sounds made by Fin Whales (frequencies around 20 hertz, or cycles per second) actually travel underwater for distances of at least 500 miles, and under optimum conditions might carry for a radius of over 4,000 miles, potentially reaching an area greater than the entire Atlantic Ocean.

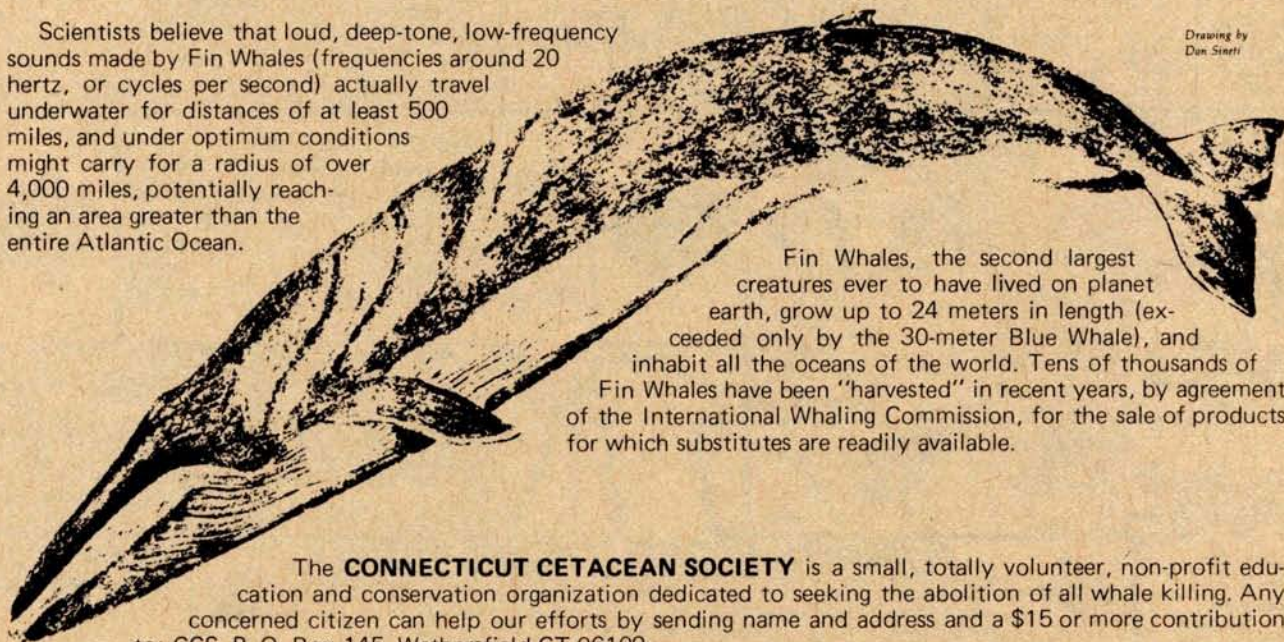

Fin Whales, the second largest creatures ever to have lived on planet earth, grow up to 24 meters in length (exceeded only by the 30-meter Blue Whale), and inhabit all the oceans of the world. Tens of thousands of Fin Whales have been "harvested" in recent years, by agreement of the International Whaling Commission, for the sale of products for which substitutes are readily available.

The **CONNECTICUT CETACEAN SOCIETY** is a small, totally volunteer, non-profit education and conservation organization dedicated to seeking the abolition of all whale killing. Any concerned citizen can help our efforts by sending name and address and a \$15 or more contribution to: CCS, P. O. Box 145, Wethersfield CT 06109.

HICKOK LX303

\$74.95*



1.5%, 3 1/2 digit 19 Range DVM. 1/2" LCD displays runs 200 hrs on 1 battery. 10 Meg Ohm Input. 1 yr. guarantee, made in U.S.A., test leads included.

- Available Accessories**
- RC-3 115V AC Adapter \$7.50
 - CC-3 Deluxe Padded Vinyl Carrying Case \$7.50
 - VP-10 X10 DCV Probe Adapter/ Protector 10kV \$14.95
 - VP-40 40kV DC Probe \$35.00
 - CS-1 10 Amp Current Shunt \$14.95

***FREE**

Just for Asking. **FREE BATTERY** with your meter.

RS232 & "D" TYPE CONNECTORS

P = Plug Male S = Socket-Female C = Cover-Hood

PART NO.	DESCRIPTION	PRICE
DE-9P	9 Pin Male	1.4 5-9 10-24
DE-9S	9 Pin Female	1.50 1.30 1.20
DE-9C	9 Pin Cover	2.15 2.05 1.95
DA15P	15 Pin Male	2.20 2.00 1.80
DA15S	15 Pin Female	3.20 3.00 2.80
DA15C	15 Pin Cover	1.60 1.45 1.30
DB-25P	25 Pin Male	2.80 2.60 2.50
DB-25S	25 Pin Female	3.75 3.85 3.40
DB51212-1	1 pc. Gray Hood	1.85 1.40 1.20
DB1226-1A	2 pc. Black Hood	1.90 1.60 1.50
DB110963-3	2 pc. Gray Hood	1.80 1.55 1.35
DC37P	37 Pin Male	3.95 3.80 3.60
DC37S	37 Pin Female	5.75 5.50 5.20
DC37C	37 Pin Cover	2.20 1.95 1.75
DD50P	50 Pin Male	4.95 4.75 4.50
DD50S	50 Pin Female	7.50 7.20 6.90
DD50C	50 Pin Cover	2.50 2.20 2.10
D20418-S	Hardware Set (2 pair)	1.00 .80 .70

Connector for CENTRONICS 700 SERIES: Amphenol 57-30360 for back of Centronics 700 Series printers 1.4-\$9.00 5-up-\$7.50

SALE S-100 BUS EDGE CONNECTORS SALE

PART NO.	DESCRIPTION	PRICE
S100-WWG	50/100 Cont. 125 ctrs. 3 LEVEL WIRE WRAP .025" sq. posts on 250 spaced rows. GOLD PLATED	1-4 5-9 10-24 \$4.00 \$3.75 \$3.50
S100-STG	50/100 Cont. 125 ctrs. DIP SOLDER TAIL on 250 spaced rows for VECTOR, IMSAI, CROMEMCO motherboards GOLD PLATED	1-4 5-9 10-24 \$3.50 \$3.25 \$3.00
S100ALT	50/100 Cont. 125 ctrs. DIP SOLDER TAIL on 140 spaced rows for ALTAIR motherboards. GOLD PLATED	1-4 5-9 10-24 \$4.50 \$4.25 \$4.00
D2244-SSE	22/44 Cont. 156 ctrs. PIERCED SOLDER EYELET tails. GOLD	1-4 5-9 10-24 \$3.00 \$2.60 \$2.20
D2244-SWW	22/44 Cont. 156 ctrs. WIRE WRAP tails. GOLD	1-4 5-9 10-24 \$3.95 \$3.70 \$3.40

Other Popular Edge Connectors

PART NO.	DESCRIPTION	PRICE
D2244-SSE	22/44 Cont. 156 ctrs. PIERCED SOLDER EYELET tails. GOLD	1-4 5-9 10-24 \$3.00 \$2.60 \$2.20
D2244-SWW	22/44 Cont. 156 ctrs. WIRE WRAP tails. GOLD	1-4 5-9 10-24 \$3.95 \$3.70 \$3.40

CG-1 IMSAI Style Card Guides 5/\$1.00

See our July Ad for many other connectors.

3 LEVEL GOLD WIRE WRAP SOCKETS

Sockets purchased in multiples of 50 per type may be combined for best price.

Pin	1-9	10-24	25-99	100-249	250-999
8 pin	.40	.36	.34	.31	.27
14 pin	.39	.38	.36	.34	.32
16 pin	.50	.42	.40	.36	.34
18 pin	.70	.60	.55	.50	.45
20 pin	.90	.80	.75	.65	.62
22 pin	.95	.85	.80	.70	.65
24 pin	.95	.85	.80	.70	.65
28 pin	1.25	1.15	1.00	.95	.90
40 pin	1.65	1.45	1.35	1.20	1.10

All sockets are GOLD 3 level closed entry. 2 level Tail, Low Profile, Tin Sockets and Dip Plugs available. CALL FOR QUOTATION.

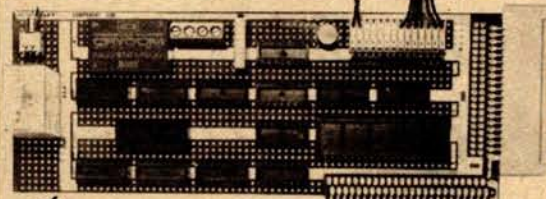

APPLE PLUGBOARD

Vector 4609 Peripheral Interface Plugboard for construction of custom circuits. Plug compatible with Apple II, Commodore PET and Super Kim microcomputers. Three connectors, in addition to the standard 25/50 system bus, are available for input/output. A 20/40-contact card-edge connector, fabricated on the rear of the board, mates with a 3-M type ribbon connector. Alternatively, a right-angle solder-tail header may be positioned in this same location. The Model 4609 also accommodates the miniature SIP-type connectors which may be placed on the periphery or in mid-board.

Pin	1-4	5-9	10-24
8 pin	\$21.50	\$19.36	\$17.26

HICKOK LX303 \$74.95

HICKOK LX303 \$74.95

8803 MOTHER BOARD FOR S100 BUS MICRO COMPUTERS

Price: **\$29.50**

- Kit includes 12 tantalum capacitors for +5, +12, -12 buses and rear-panel mounting sockets.
- Wiring side shown. Component side bare epoxy glass with white markings for component locations.
- STD 8088 glass board with 2 ounce copper, solder plated lead, 038 diameter holes for leads.
- Solder mask with solder windows at critical points to avoid accidental short circuits.
- Mounts 11 receptacles with 100 contacts (2 rows) on 125 centers with 250 row spacing. Vector part number MB81-2, or mounts 10 receptacles plus microconnectors to smaller mother board for expansion.
- Includes etched circuits and instructions for option of active, pull-up, or floating terminations.
- Large buses, +5V and GND (10 AMP), ±12V or 16V (1 AMP). Current ratings per pin MIL-STD-275 with 10PC rise.
- Fits in Vector p.c. enclosures.
- Fits in IMSAI 8080 microcomputer as expansion board.

Vector Plugboards

8800V Universal Microcomputer/processor plugboard, use with S-100 bus. Complete with heat sink & hardware. 5.3" x 10" x 1/16"

8801-1 Same as 8800V except plain, less power buses & heat sink

Price: **\$15.22 \$13.79 \$12.18**

IC SOCKET SALE

14 pin Low Profile 10/\$2.10 100/\$14.00

16 pin Low Profile 10/\$2.20 100/\$16.00

24 pin Low Profile 3/\$1.00 40/\$10.00

40 pin Solder Tail 3/\$1.00 40/\$10.00

24 pin Dip Plug with cover 3/\$1.00 40/\$10.00

3677 9.6" x 4.5" \$10.90

3677-2 6.5" x 4.5" \$9.74

3662 6.5" x 4.5" \$8.95

3662-2 9.6" x 4.5" \$11.45

Gen. Purpose D.I.P. Boards with Bus Pattern for Solder or Wire Wrap. P pattern plugboards for Epoxy Glass 1/16" 44 pin con. spaced .156

CARD EXTENDER 3690-12 Card Extender has 100 contacts 50 per side on .125 centers-Attached connector is compatible with S-100 Bus Systems. \$25.83 3690 6.5" 22/44 pin .156 ctrs. Extenders \$13.17

1/16" BOARD .042 dia holes on 0.1 spacing for IC's

Phenolic

PART NO.	SIZE	1-9	10-19
64P44XXXP	4.5x6.5"	\$1.56	\$1.40
169P44XXXP	4.5x17"	\$3.69	\$3.32

Epoxy Glass

PART NO.	SIZE	1-9	10-19
64P44	4.5x6.5"	\$1.79	\$1.61
84P44	4.5x8.5"	\$2.21	\$1.99
169P44	4.5x17"	\$4.52	\$4.07
169P84	8.5x17"	\$8.83	\$7.94

TRS-80/APPLE MEMORY EXPANSION KITS

4116's RAMS from Leading Manufacturers (16Kx1 200/250ns)

8 for \$75.00

Add \$3.00 for programming Jumpers for TRS-80 Keyboard

WOW!

14 & 16 PIN GOLD 3 LEVEL WIRE WRAP SOCKETS

14 - G3 100 for \$33.00

16 - G3 100 for \$33.00

50 of each for \$35.00

PANA VISE

LOW-PROFILE BASE 305 PRICE: \$13.49

STANDARD BASE 300 PRICE: \$13.49

STANDARD VISE HEAD 303 PRICE: \$14.49

HORIZONTAL JAW VISE HEAD 304 PRICE: \$14.49

WIDE OPENING VISE HEAD 366 PRICE: \$18.49

LOCK SCREW BASE 360 PRICE: \$14.49

PANA VISE TILTS, TURNS, AND ROTATES TO ANY POSITION. IT HOLDS YOUR WORK EXACTLY WHERE YOU WANT IT.

MEMORY MEMORY

2102LIPC Low Power 450ns in lots of 25 \$1.10

2102AL-2 Low Power 250ns in lots of 25 \$1.25

2114-3L 1Kx4 300ns Low Power 8/\$50.00

5257-3L 4Kx1 300ns Low Power 8/\$50.00

2708 8K 450ns EPROM \$9.00

2716 16K 5 Volt Only EPROM \$45.00

ORDER TOLL FREE

1-800-423-5633

except CA., AK., HI., Call (213) 894-8171

Vector WRAP POST for .042 dia. holes (all boards on this page) T44/C pkg. 100 \$ 2.34 T44/M pkg. 1000 \$14.35 A-13 hand installing tool \$ 4.19

PRIORITY ONE ELECTRONICS

16723B Roscoe Blvd. Sepulveda, CA 91343

Terms: Visa, MC, BAC, Check, Money Order, C.O.D. U.S. Funds Only. CA residents add 6% sales tax. Minimum order \$10.00 Prepaid U.S. orders less than \$75.00 include 5% shipping and handling. MINIMUM \$2.50. Excess refunded. Just in case, please include your phone no. Prices subject to change without notice. We will do our best to maintain prices thru Oct. 1979. OEM and Institutional inquiries invited.

phone orders welcome (213) 894-8171, (800) 423-5633

BK PRECISION

TEST EQUIPMENT CALL FOR SPECIAL PRICES

Visit our new retail location!

Circle 312 on inquiry card.

Visit our new retail location!

Visit our new retail location!

The EXPANDORAM is available in versions from 16K up to 64K, so for a minimum investment you can have a memory system that will grow with your needs. This is a dynamic memory with the invisible on-board refresh, and IT WORKS!

- Interfaces with Altair, IMSAI, SOL-8, Cromenco, SBC-100, and others.
- Bank Selectable
- Phantom
- Power 8VDC, ± 16VDC, 5 Watts
- Lowest Cost Per Bit
- Uses Popular 4116 RAMS
- PC Board is doubled solder masked and has silk-screen parts layout.

SD EXPANDORAM

The Ultimate S-100 Memory

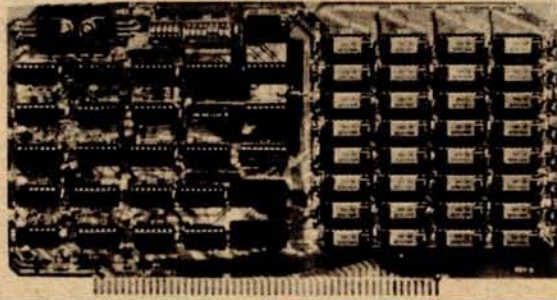

- Extensive documentation clearly written
- Complete Kit includes all Sockets for 64K
- Memory access time: 375ns, Cycle time: 500ns.
- No wait states required.
- 16K boundaries and Protection via Dip Switches
- Designed to work with Z-80, 8080, 8085 CPU's.

EXPANDO 64 KIT (4116)

16K	\$249
32K	\$324
48K	\$399
64K	\$474

DISC DRIVES

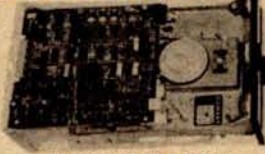

SHUGART SA 400 5 1/4"
110 KB, 35 tracks,
SHUGART SA 400 **\$295.00**
SHUGART SA 400
with attractive metal case with cutouts for Data Cable switch, fuse and power cord
LOBO SA400-C **\$325.00**
SHUGART SA400
with Cabinet and Power Supply. Assembled, tested & guaranteed
LOBO SA400-PC **\$395.00**
SHUGART 801R 8"
6.4 megabits, single or double density, hard or soft sector, write protect, and more
SHUGART 801R **\$449.00**
Siemens FDD 200-8 8"
double-sided double density
\$650.00

DISC CONTROLLER

SD "VERSAFLOPPY" Kit

The Versatile Floppy Disk Controller Only **\$159.00**



FEATURES: IBM 3740 Soft Sectored Compatible, S-100 BUS Compatible for Z-80 or 8080. Controls up to 4 Drives (single or double sided). Directly controls the following drives:
1. Shugart SA400/450 Mini Floppy
2. Shugart SA800/850 Standard Floppy
3. PERSCI 70 and 277.
4. MFE 700/750.
5. CDC 9404/9406.
6. GSI/Siemans FDD120-8.
34 Pin Connector for Mini Floppy, 50 Pin Connector for Standard Floppy. Operates with modified CPM operating system and C-Basic Compiler. The new "Versafloppy" from S.D. Computer Products provides complete control for many of the available Floppy Disk Drives. Both Mini and Full Size, FD1771S-1 Single Density Controller Chip. Listings for Control Software are included in price.
CPM for SD Versafloppy **\$100.00**

DUAL SHUGART DISC DRIVES

New from Lobo Drives, a dual Cabinet complete with power supply, and Shugart 801R disc drives.

- Cabinet accepts 2 801R drives mounted side by side horizontally.
- Power Supply for 2 drives
- Ad-on drives available
- Assembled, tested and guaranteed by Lobo Drives.
- Single or double density • Hard or soft sector • Write Protect
- Capacity: Unformatted single density 3.2 megabits double density 6.4 megabits

IBM format, 2 megabits

- 500 KBS transfer, 77 tracks.
- Shugart 800 Series Compatible

LOBO 801R-1 Pcs. Dual Cabinet with 1 drive	\$599.00
LOBO 801R-2 Pcs. Dual Cabinet with 2 drives	\$1025.00
SHUGART 801R Ad-on disc drive	\$449.00



SAVE \$120.00

ASSEMBLED & TESTED SALE PRICED

M32 KSS-L (2 MHz)

List \$650

SALE \$530.00

M32 KSS-H (4 MHz)

List \$680

SALE \$560.00

THE MICROBYTE M32KSS 32K STATIC MEMORY BOARD



- Fully S100 Bus Compatible, IMSAI, SOL, ALTAIR, ALPHA MICRO.
- Uses National's Low Power 5257 4K x 1 Static Rams. • 2 MHz or 4 MHz operation. • Gold contacts for higher reliability. • On board single 5 amp regulator. • Thermally designed heat sink (board operating temperature 0° - 70°C). • Commercially designed power bus, 7 ground bus bars, 0.1 uf decoupling capacitors. • Fully tri-state buffered. • Inputs fully low power Shottky Schmitt, Trigger buffered on all address and data lines. • Phantom is jumper selectable to pin 67. • Each 4K bank addressable to any 4K slot with in a 64K boundary. • 4K hardware or software selectable. • One on board 8-bit output port enables or disables the 32K in 4K blocks. • Selectable port address. • 4K banks can be selected or disabled on power on clear or reset. • Will operate with or without front panel. • Compatible with ALPHA MICRO, with extended memory management for selection beyond 64K. • No DMA restriction. • Low power consumption 2.3 - 2.5 amps. • Fully warranted for 120 days from date of shipment.

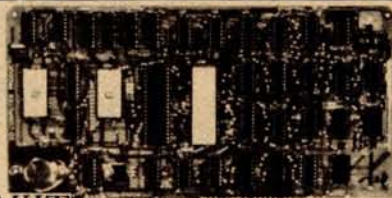

\$319 KIT VDB-8024 Video Display Board With On-Board Z80 Microprocessor

- Full 80 Characters in 24 lines display
- Characters displayed by High Resolution 7x10 Matrix
- Keyboard Power and Interface
- Composite Video Output
- Separate TTL Level Synchronization and Video Outputs
- 2K Bytes Independent On Board Memory
- On Board Z80 Microprocessor
- Glitch Free Display
- 96 Upper and Lower Case Characters
- 32 Special Character Set
- 128 Additional user Programmable Characters
- Full Cursor Control
- Forward and Reverse Scrolling Capability
- Operates as an Independent Terminal
- Variable Speed Display Rate
- Blinking, Underlining, Field Reverse, Field Protect and Combinations.

SD COMPUTER BOARDS

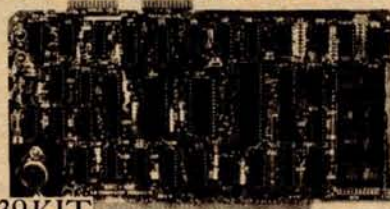

\$239 KIT SBC-100 Single Board Computer with On-board RAM, PROM, CTC

- Four Channel Counter/Timer (Z80-CTC)
- Software Programmable Band Rate Generator
- S-100 Bus Compatible
- No Front Panel Required for Operation
- Optional Vectored Interrupts
- Z80 Central Processing Unit (Z80-CPU)
- 1024 Bytes of Random Access Memory
- 8K Bytes of Available PROM
- Serial Input/Output Port with both Synchronous and Asynchronous Operation
- Parallel Input and Output Ports

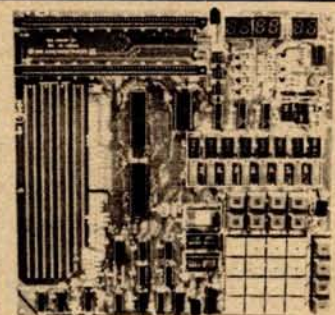

\$249 Z80 Starter Kit A Complete Microcomputer on a Board

- Z80 Central Processing Unit with 16K Instructions
- On Board Keyboard and Display
- Kansas City Standard Cassette Interface
- PROM Programmer Built on-board
- Expansion provision for two S-100 Connectors
- Wire Wrap area for custom circuitry
- Single 8 Volt Operation when not programming
- 1K Bytes of RAM (Expandable to 2K Bytes)
- 1K Bytes of RAM (Expandable to 2K Bytes)
- 4 Channel Hardware Counter/Timer (Z80-CTC)
- Two Bi-directional 8-bit I/O Ports (Z80-PIO)
- Switch Selectable PROM or Monitor Restart
- 2K Byte Z80 Tr Monitor in ROM
- Memory Examine and Change
- Port Examine and Change
- Z80 CPU Register Examine and Change
- 1 p to 8 Programmable Breakpoints
- Single Step through RAM or PROM
- Audio Cassette Load and Dump
- Vectored Interrupts provided by Z80-CTC and Z80-PIO
- Ideal for Experimentation and Evaluating the Z80 CPU



PRIORITY ONE ELECTRONICS

16723B Roscoe Blvd. Sepulveda, CA 91343

Terms: Visa, MC, BAC, Check, Money Order, C.O.D. U.S. Funds Only. CA residents add 6% sales tax. Minimum order \$10.00 Prepaid U.S. orders less than \$75.00 include 5% shipping and handling, MINIMUM \$2.50. Excess refunded. Just in case... please include your phone no.

Prices subject to change without notice.

We will do our best to maintain prices thru Oct. 1979.

phone orders welcome (213) 894-8171, (800) 423-5633

OEM and Institutional inquiries invited.

ORDER TOLL FREE 1-800-423-5633

ORDER TOLL FREE 1-800-423-5633

TRS-80 DISC DRIVE

\$395⁰⁰

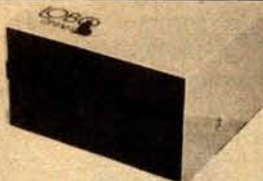

Shugart SA400, housed in an attractive metal case, complete with power supply and termination network. All you need to do is connect the drives to your expansion interface.

1410 \$835⁰⁰

- Separate integral 12-key Numeric Pad
- All 128 ASCII Codes
- 64 Displayable Characters
- 24x80 Screen Configuration
- High Resolution using a 5x7 Dot Matrix
- TTY-Style Keyboard Layout
- Cursor Addressing and Sensing
- EIA Interface
- Eight Selectable Transmission Rates up to 9600 Baud
- Microprocessor Based
- Remote Commands
- Attractive Styling for Contemporary Environments

Hazeltine 1400 same as 1410 less numeric pad \$735⁰⁰



1¢ SALE

buy a MICROPRINTER and get a CASE OF PAPER FOR 1¢. Reg. \$25.00 value.

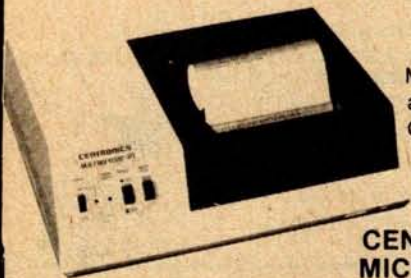

CENTRONICS® MICROPRINTER Nonimpact Desk-Top Printers

FEATURES

- 150 Lines Per Minutes
- 96 Characters — Upper and Lower Case
- 5/10/20 Characters/Inch — Software Selectable
- Elongated Characters • Underlining
- Simplified Operation • Quiet
- Audio Alarm • Long Life — Only 4 Moving Parts
- Small Size and Light Weight
- No Toners/Ribbons Required

S1 Serial Interface Features \$595⁰⁰

- 7-Bit ASCII, Serial RS232C Interface with Parity Selection
- Switch-Selectable Baud Rate: 50 to 9600
- 192 Character FIFO Buffer

P1 Parallel Interface Features \$495.00

- 7-Bit ASCII
- TTL Compatible Input/Output Signals
- Compatible with Centronics and other Printer Product Lines

Centronics new compact MICROPRINTER is available in parallel and serial interface versions to satisfy a wide range of printer applications. The primary difference between the two models is the inclusion of an RS232C serial interface and 192 character FIFO buffer in the Model S1.

Both models employ nonimpact discharge technology that requires only four moving parts to produce variable pitch 5 x 8 dot matrix characters at a rate of 150 lines per minute — with exceptional clarity. The paper requires no toners or ribbons. Instead, it carries a conductive aluminized coating which is vaporized by a low voltage discharge from the print head to produce highly readable characters.

Use with TRS-80 CENTRONICS 779 PRINTERS

- Parallel interface
- Continuous variable printing density 80-132 characters per line
- 5x7 dot matrix
- Prints on plain paper, sheets, rolls, fan fold
- Form thickness control
- Horizontal and vertical form positioning

779-1 pinch roll friction feed
Reg. \$1250 **\$950⁰⁰**

779-2 tractor feed
Reg. \$1400 **\$1050⁰⁰**

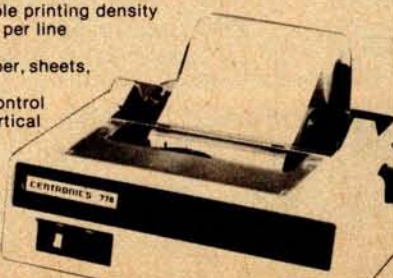

Call for Discount Prices on Other Centronics Printers

Portable Miniscopes for Electronic Professionals on the Go!!! The Standout Oscilloscope development of the decade!!! Now -30MHz, dual trace model. Compare the performance, then compare the price.

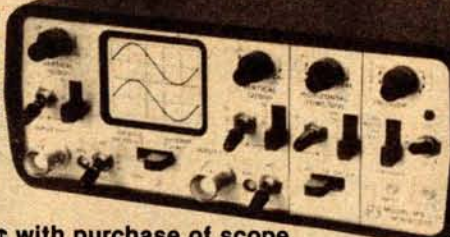

1¢ sale Probes 1¢ with purchase of scope

- 30-Megahertz bandwidth • Accuracy 3% full scale. • Internal, line or external trigger. • Batteries and charger/transformer unit included • Graticule: 4x5 divisions, each division 0.25" • Time base: 1 micro sec. to 0.5 sec/div 21 settings • Vertical Gain: 0.01 to 50 Volts/div. 12 settings • Size 2.9"H x 6.4"W x 8.5"D. 3.5 lbs. • TEST MOST DIGITAL LOGIC CIRCUITS INCLUDING MICROPROCESSORS •

- 41-141** Deluxe 10tol/1tol probe with 4 interchangeable tips **\$27.00**
- 41-37** Deluxe 10tol/1tol probe with 4 interchangeable tips **\$38.50**
- 41-180** leather carrying case **\$45.00**
- MS-15** Single trace 15 MHz **\$318.00**
- MS-215** Dual trace 15 MHz **\$435.00**

3M Scotch® Brand DISKETTES

Part #	Sides/Density	Sectoring	Price Box of 10
8"			
740-OP	1/single	Soft-IBM	\$39.95
740/2-OP	2/single	Soft-IBM	\$75.00
740-32P	1/single	32-Shugart 801	\$39.95
740/2-32P	2/single	32-Shugart 801	\$75.00
741-O	1/double	Soft-Shugart Dbl	\$59.00
5"			
744-OK	1/single	Soft-Shugart SA400 (TRS-80)	\$51.00*
744-10K	1/single	Soft/10 SA400	\$51.00*
744-16K	1/single	Soft/16 Micropolis	\$51.00*

*Price includes Kas-ette/10 Storage Box a \$5.00 Value
"DON'T SETTLE FOR ANYTHING LESS THAN SCOTCH"

ACOUSTIC MODEM NOVATION CAT

- 0-300 Baud
- Bell 103
- Answer, Originate

Reg. \$198.00

Sale \$189.00



CONTINENTAL SPECIALTIES CORPORATION



100 MHz 8-Digit Counter



- 200 Hz-100 MHz Range
- 6" LED Display
- Crystal-controlled timebase
- Fully Automatic
- Portable - completely self contained
- Size - 1.75" x 7.38" x 5.63"
- Four power sources, i.e. batteries. 110 or 220V with charger 12V with auto lighter adapter and external 7.2-10V power supply.

\$134.95 Sale \$120.00

- ACCESSORIES FOR MAX 100:**
- Mobile Charger Eliminator use power from car battery Model 100-CLA \$3.95.
- Charger/Eliminator use 110 VAC Model 100 — CA1 \$9.95

CONTINENTAL SPECIALTIES CORPORATION



SALE

REG. \$39.95

LOGIC MONITOR 1

Trace signals through all types of digital circuits. Unit clips over any DIP IC up to 16 pins. Each of its 16 contacts connects to a single-bit level detector that drives a high-intensity, numbered LED readout activated when the applied voltage exceeds a fixed 2 V threshold. Logic "1" turns LED on; logic "0" keeps LED off. A power-seeking gate network automatically locates supply leads and feeds them to the LM-1's internal circuitry. Saves minutes, even hours in design, troubleshooting, debugging of equipment. **Voltage Threshold:** 2 V ± 0.2 V. **Input Impedance:** 100,000 ohms. **Input Voltage Range:** 4-15 V max. across any two or more inputs. **Current Drain:** 200 mA at 10 V. **Size:** 4" l. x 2" w. x 1.75" d. when open. **Weight:** 3 ozs. **CSC Model LM-1 Logic Monitor—Complete.**
Sale Price **\$54.95**

PRIORITY ONE ELECTRONICS®

16723B Roscoe Blvd. Sepulveda, CA 91343

Terms: Visa, MC, BAC, Check, Money Order, C.O.D. U.S. Funds Only. CA residents add 6% sales tax. Minimum order \$10.00 Prepaid U.S. orders less than \$75.00 include 5% shipping and handling. MINIMUM \$2.50. Excess refunded. Just in case . . . please include your phone no.

Prices subject to change without notice. We will do our best to maintain prices thru Oct. 1979.

phone orders welcome (213) 894-8171, (800) 423-5633

OEM and Institutional Inquiries invited.

Visit our new retail location!

Visit our new retail location!

The Jim-Pak News Herald

1021 Howard Street • San Carlos, California 94070 • (415) 592-8097

ANOTHER QUALITY **Jim-pak** KIT ANNOUNCED!

electronic components

SAN CARLOS, California (JE) — Jim-Pak Components today announced the addition of another innovative kit to

their growing line of quality electronic kits for the home enthusiast. The JE610 62-key

ASCII Encoder Computer Keyboard is now available through JIM-PAK distributors.

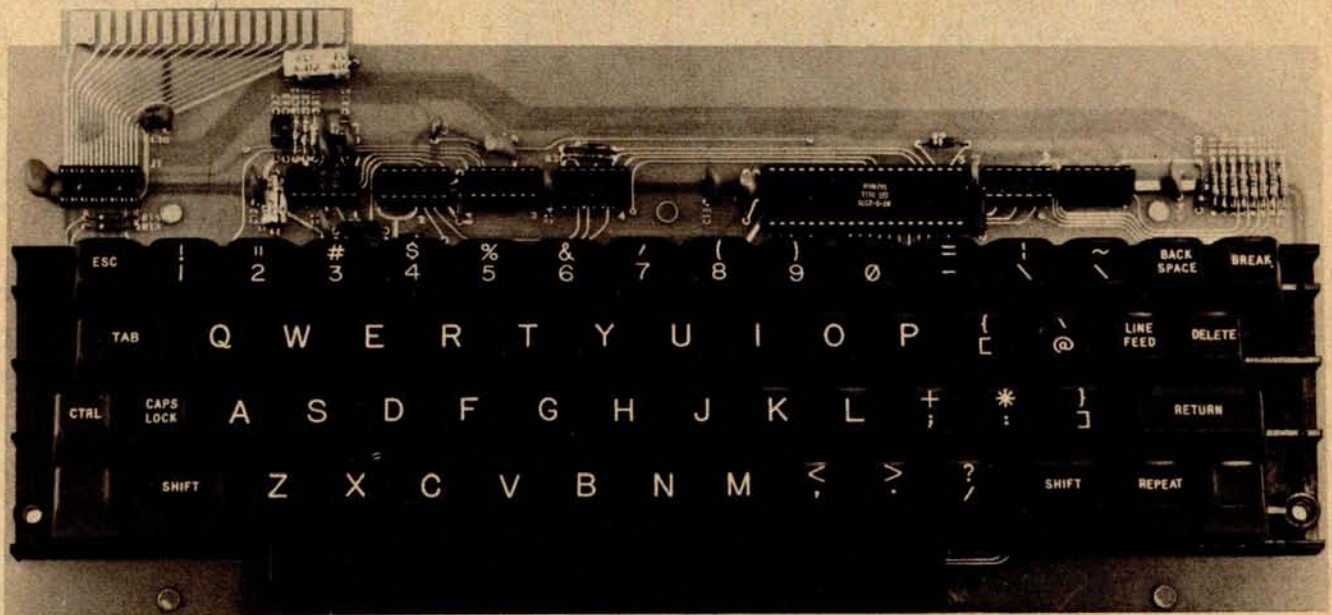

62-Key ASCII Encoder Keyboard Kit

THE JE610 62-KEY ASCII ENCODER KEYBOARD KIT CAN BE INTERFACED INTO MOST ANY COMPUTER SYSTEM. THE JE610 KIT COMES COMPLETE WITH AN INDUSTRIAL GRADE KEYBOARD SWITCH ASSEMBLY (62 KEYS), IC'S, SOCKETS, CONNECTOR, ELECTRONIC COMPONENTS AND A DOUBLE SIDED PRINTED WIRING BOARD. THE KEYBOARD ASSEMBLY REQUIRES +5V @ 150mA AND -12 V @ 10mA FOR OPERATION.

FEATURES:

- 60 KEYS GENERATE THE FULL 128 CHARACTERS, UPPER AND LOWER CASE ASCII SET
- FULLY BUFFERED
- 2 USER DEFINE KEYS PROVIDED FOR CUSTOM APPLICATIONS
- CAPS LOCK FOR UPPER CASE ONLY ALPHA CHARACTERS
- UTILIZES A 2376 (40 PIN) ENCODER READ ONLY MEMORY CHIP
- OUTPUTS DIRECTLY COMPATIBLE WITH TTL/DTL OR MOS LOGIC ARRAYS
- EASY INTERFACING WITH A 16-PIN DIP OR 18-PIN EDGE CONNECTOR

JE610

What's New?

PERIPHERALS

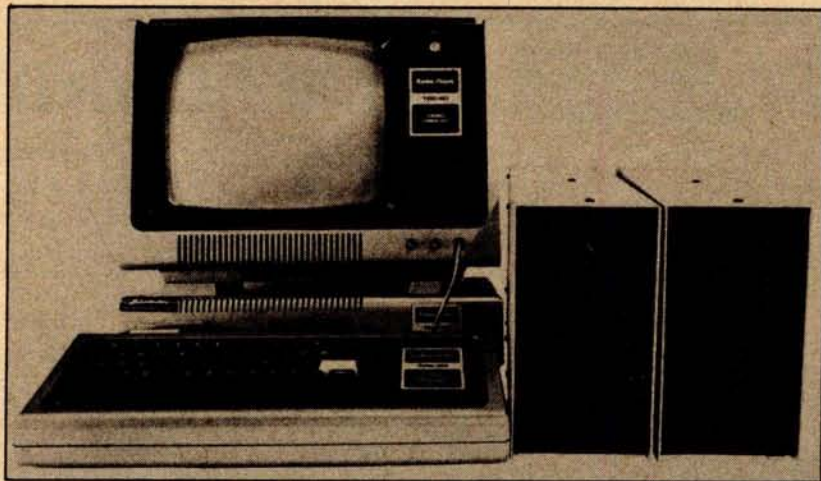

8-Inch Floppy Disk Drive for TRS-80 Computer

This Shugart 800-based floppy disk system, called Maxi-Disk, is fully compatible with existing TRS-80 5-inch floppy disk drives, and can be mixed and matched with smaller drives. The system plugs into the TRS-80 expansion interface. The user has only to remove the disk controller device from the expansion interface, and replace it with a specially designed circuit board. In this circuit board is a socket where the controller device is reinserted. All necessary

parts and instructions are provided. No soldering or trace cutting is necessary.

The system also allows the user to use the expansion interface as it is designed since the only change is to turn the disk controller from a 5-inch only controller to an 8-inch and/or 5-inch controller.

The Maxi-Disk system sells for \$995 which includes the 8-inch drive, the interface board, and a patch to the TRS-DOS that allows the user to access a variety of drives. For more information, contact Parasitic Engineering, POB 6314, Albany CA 94706.

Circle 608 on inquiry card.



Dual Serial Interface for TRS-80 Computer

The DSI-80 is a dual serial interface for use with the Radio Shack TRS-80 computer. It provides 2 serial output ports with both current loop and RS-232 interface. Speed selections of 110, 150, 300, 600 and 1200 bits per second (bps) are accomplished by jumpers which require no special tools or soldering. The unit is built to MIL specifications and burned-in for a minimum of 120 hours before shipment. All integrated circuits are socketed and the timebase is crystal controlled.

The cassette tape provided with the

DSI-80 contains several I/O (input/output) programs written in BASIC, intended to show how other BASIC programs can use the interface. The tape also contains system programs written in assembly language to patch the BASIC interpreter in the TRS-80, so that common time-sharing type terminals can be used to run BASIC and to receive output from the LPRINT AND LLIST commands.

The unit, complete with manual, cassette tape, and 6 month warranty is available for \$199.95. For further information, contact Polytronics, Methodist Hill, Lebanon NH 03766.

Circle 609 on inquiry card.

S-100 Four Channel 12-Bit Digital-to-Analog Converter

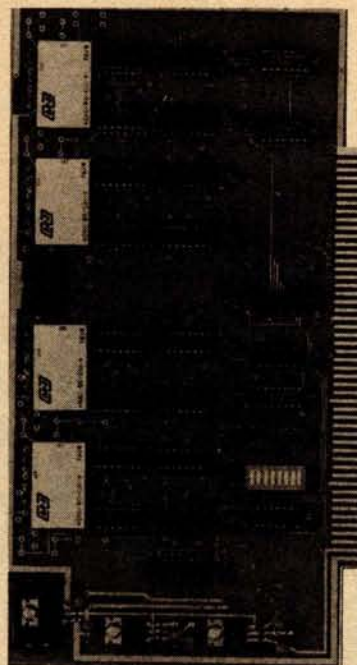

The Tecmar S-100 D/A board is designed for applications requiring high-speed accurate digital-to-analog conversion including real-time applications. This board supports four independent high-speed digital-to-analog converters (DACs) with associated latches. Each DAC operates independently of the rest. The DACs have a conversion time of 3 μ s which enables them to operate at maximum computer speed. A 12-bit latch drives the inputs of each DAC. Another 4-bit latch for each DAC holds the four new most significant bits waiting for the arrival of the new least significant byte. This allows the DAC to hold its previous value until an entire new word is presented to it. All the latches are set to zero by reset. To modify the contents of a latch, and hence the output of a DAC, it is necessary to send two bytes to the device. The input is a 12-bit in a two's complement format. The board may be addressed as I/O ports or memory mapped.

The S-100 D/A Converter Board is priced at \$395 and comes complete with documentation; the S-100 D/A Technical Manual is \$15. All boards are assembled and tested and have a 90-day warranty. For further information, contact Tecmar Inc, 23414 Greenlawn Ave, Cleveland OH 44122.

Circle 610 on inquiry card.

California Digital

Post Office Box 3097 B • Torrance, California 90503



Sankyo Magnetic Card Reader

\$59

These Sankyo I/O units are capable of storing and retrieving over 400 characters of data in under two seconds. The flexibility of this device lends itself to numerous applications. As an input reader to a computerized security system, the computer has the ability of identifying the card holder and admitting only those individuals who are authorized to enter the premises during specified time frames. The device is also suitable for maintaining customer information files, or any other application where small amounts of information must be quickly entered into a data processing system. Accepts 2" by 4" HP style mag-cards. (Similar to bank cards.) Motorized feeder pulls the magnetic card across the four channel read/write head. NEW surplus, original cost \$200. Full documentation

S-100 Mother Board

Quiet Bus

\$29.95
8803-18
1B slot
1MSAI



The Quiet Bus from California Industrial is quality engineered. No short cuts have been taken to produce this mother board. Active termination circuitry prevents noise and crosstalk. Manufactured from extra heavy FR-4 epoxy glass

TELETYPE MODEL 43

Even if we have to give them away, we're going to ship more 43's in 1979 than the aggregate of all our competitors.



Model 43AAA TTL)
EACH 3 10 25
\$925. 875. 850. 825.
R5-232 Interface "K" Add \$75.00 plus shipping

HEXADECIMAL KEYBOARD

Maxi-Switch hexadecimal keyboards are designed for microcomputer systems that require 4-bit output in standard hex code.

Each assembly consists of 16 hermetically sealed reed switches and TTL "one-shot" debounce circuitry. Reliable low friction acetal resin plungers are credited for the smooth operation and long life of this premium keyboard. Requires single +5 volt supply.



\$34.95

FREE PLASTIC LIBRARY CASE with purchase of each box of ... Verbatim mini-diskettes. 35 value.

\$29.95
BOX OF 10
DISKETTES

CONNECTORS

your choice
DB25P male plug & hood
or
DB25S female
\$3.95

Qty.	fe.	male	hd.
10	3.45	2.45	1.15
25	3.15	2.25	1.05
100	2.85	1.90	.95
500	2.25	1.60	.85
1K	1.97	1.37	.73

Edge Connectors

GOLD 100 PIN IMSAI/ALTAIR

Imesai solder .125x.250	\$3.95	3/4	9.00
Imesai w/w .125scanters	\$4.95	3/8	13.00
Altair solder tail .140 row	\$5.95	3/8	15.00

SPECIALS

22/44 Kim system .156"	\$1.95	3/4	15.00
22/40 solder tab .156"	\$1.95	3/4	12.00
36/72 wide post w/w .156"	\$1.95	3/4	15.00



\$24.88

MODULATOR

The Atari R.F. Modulator allows computer data to be displayed directly upon your existing television system. This unit converts the signal from the Apple II and other video sources into television frequencies. Operates from single 5 volt supply. Complete with metal case, mating R.F. connector and 15 feet of coax cable. Schematics and instructions included.



\$13.95

SPECIAL APPLE II 16K MEMORY

COLOR • GRAPHICS • SOUND
\$1024
PLUS SHIPPING
Mfg. Sug. Retail... \$1195

TEN \$41 for 50+ \$385

Scotch BRAND CASSETTES

Certified Digital
Wont drop a BIT!

DISKETTES

- 8 inch Soft (IBM)
- 8 inch 32 sector
- Mini Soft sec.
- Mini 10 sector
- Mini 16 sector

\$5.50
CALIFORNIA INDUSTRIAL is an Authorized Dealer of Scotch Brand Data Products

Shugart Associates

SABOO-R Floppy Disk Drive
The most cost effective way to store data processing information, when random recall is a prime factor. The SABOO is fully compatible with the IBM 3740 format. Write protect circuitry, low maintenance & Shugart quality.
\$449.50

\$85 KEYBOARD ASCII ENCODED

KEYTRONIC ASCII & ASCII complement.
*Ten key data pad
*Cursor controls
*Six user switches
*Alpha Lock
*Auto repeat
*Single 5 volt.
*Glass reed.
NEW

MEMORY

TRS-80 \$65
APPLE II
16k memory (8) 4116's

As you may be aware, publishers require advertisers to submit their ad copy 60 to 90 days prior to "press" date. That much lead time in a volatile market place, such as memory circuits, makes it extremely difficult to project future cost and availability. To obtain the best pricing on memory we have made volume commitments to our suppliers, which in turn affords us the opportunity to sell these circuits at the most competitive prices. Please contact us if you if you have a demand for volume state of the art memory products.

STATIC	1-31	32-99	100-5C	999	1K+
21L02 450nS.	1.19	.99	.95	.90	.85
21L02 250nS.	1.49	1.39	1.25	*	*
2114 1Kx4 450	5.95	5.50	5.25	4.75	4.50
2114 1Kx4 300	8.95	8.50	8.00	*	*
4044 4Kx1 450	5.95	5.50	5.25	*	*
4044 4Kx1 250	9.95	9.50	9.00	*	*
4045 1Kx4 450	8.95	8.50	8.00	*	*
4045 1Kx4 250	9.95	9.50	9.00	*	*
5257 low pow.	5.95	5.50	5.00	4.80	4.60

SPECIAL CIRCUITS

Z80A 4MHz.	24.95	AY5-1013A UART	4.95
8080A CPU	8.95	Floppy Drive Controllers	
8085	22.50	WD 1771 single D.	39.95
8086 Intel 16 bits	*	WD 1781 Double D.	85.00
TMS9900 16 bits	49.95	WD 1791 D/D	37.40



EPROMS

	1-15	16-63	64+
1702A 2K	4.95	4.50	4.00
2708 8K	9.95	9.50	9.00
2716 5v16K	39.95	35.00	*
2716 T1	24.88	20.00	*
2532	*	*	*



\$139.50

PORTABLE DATA ENTRY SYSTEM
These used data terminals were originally designed for chain store inventory control and order entry systems. The operator enters the inventory control number, merchandise on hand and the unit price. After all pertinent data has been entered into the recorder, the main warehouse is telephoned, the handset is placed in the acoustic coupler and all the recorded information is transmitted back to the master computer. With a little imagination and one of these portable entry systems, you should be able to exchange programs and computer information with associates across the country. All units were removed from service in working condition. Original cost \$2,500. Each system comes complete with:

- Portable Cassette Drive Unit
- Removable Entry Keyboard with LED Display
- Five Gould "D" NiCads
- Acoustical Coupler
- Battery Charger
- DB25 Cable
- Shoulder strap
- Full Documentation

SYSTEM X-10

It's not often that California Digital ventures into the distribution of consumer products, but we have recently come across a product that appears so unique that we just had to add it to our product line. This is the System X-10 manufactured by the BSR turntable company. This space age system will remotely control any light or appliance in your home or office. Command signals are transmitted from the command console over your existing wiring. From your bed or easy chair you can control up to 16 different electrical devices inside and outside your home. Use the System X-10 to control your stereo, television or any light fixture on the premises. The basic sampler package comes complete with command console, battery operated ultrasonic controller, one each of the appliance module, lamp module and wall switch. The basic package is priced at only \$89.50. Additional modules are available for \$13.95 each.

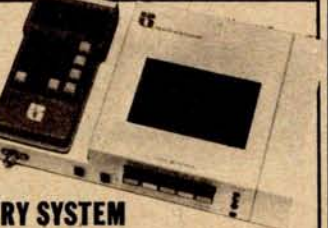

MINIATURE SWITCHES

your choice

	ea.	10	50	100	1k
SPDT Miniature Toggles	\$9.98	\$88	\$1.73	\$6.66	

7101 CAK ON-NONE-ON
7107 jdt ON-OFF (mnt. ON)
7108 CK ON-(moment. ON)
Rocker JBT DPDT
Rotary 3P-4-Pos.
Rotary 3P-6-Pos.
Push B (M.O.) 5.30ea-4/\$1

DIP Switch

	ea.	10	25	100	1k
specify 4 or 8 pos.	\$1.49	\$12.95	\$15.97	\$33	

Wire Wrap Center

IC SOCKETS

pin	Wire Wrap		low profile			
	ea.	25	50	ea.	25	50
8				17	16	15
14	37	36	35	18	17	16
16	38	37	36	19	18	17
24	99	93	85	36	35	34
40	100	155	139	63	60	58

50ft. **\$98**
500 1,000 11,000
\$9. \$15. \$105.

KYNAR WIRE WRAP
DK HOBBY WRAP-20
MINI WRAP-A-STEP 1001
\$5.45



(213)679-9001

All merchandise sold by California Digital is premium grade. Sorry, no C.O.D.'s. Orders are shipped the same day received. California residents add 5%. Foreign orders add 10%. Orders over \$25, when accompanied by payment, are shipped at our expense. Otherwise, please add \$2.

Circle 39 on inquiry card.

JADE Computer Products

JADE'S NEW MAINFRAME THE PIGGY IS HERE!

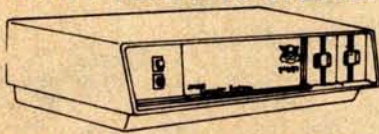

This sleek new mainframe is beautifully designed around JADE'S six slot ISO-BUS motherboard and an 18 amp power supply with provisions for up to 3 mini-floppy drives. This is a practical, state-of-the-art design whose looks just can't be beat!
ENS-106320 (without drives) \$475.00

VISTA V80

TRS-80
MINI-DISK
SYSTEM



The V80 out-performs standard Radio Shack drives!—23% more storage capacity, 8 times faster access time, more reliable, and much less expensive. Includes disk drive, power supply, regulator board, and case. MSM-358000 \$395.00
Interface cable for V80 WCA-3421 \$24.95

DISKETTE SPECIAL

5.25" SOFT, 10, OR 16 SECTOR

10 for \$29.95

8" SOFT SECTOR IBM COMPATIBLE
10 for \$34.95

S-100 CONNECTOR SALE

100 PIN IMSAI TYPE SOLDER-TAIL CONNECTOR

6 for \$17.50

12 for \$29.95

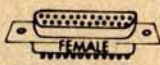
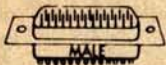

RS-232 SET SPECIAL \$6.50

DB-25S, DB-25P, DB-25 COVER

DB-25S (FEMALE) \$3.65
DB-25P (MALE) \$3.15
DB-25C (COVER) \$1.50

SPST DIP SWITCHES



PART NUMBER	NUMBER OF SWITCHES	PRICE
SWD-103	3	\$1.18
SWD-104	4	\$1.20
SWD-105	5	\$1.24
SWD-106	6	\$1.28
SWD-107	7	\$1.30
SWD-108	8	\$1.34
SWD-109	9	\$1.36
SWD-110	10	\$1.38



16 PIN ZIP* DIP II \$5.50
24 PIN ZIP* DIP II \$7.50
40 PIN ZIP* DIP II \$10.25

* ZERO INSERTION PRESSURE

JADE'S NEW INTELLIGENT CONTROLLER THE DOUBLE-D

Read/write in single or double density.
8" or 5 1/4" drives.
CP/M compatible in either single or double density.
On-board Z-80 CPU allows universal compatibility.
Programmed data transfer. No DMA.
Controls up to 8 drives.
Software selectable density.
Our new controller utilizes the IBM standard formats for proven reliability. Data recovery is enhanced through the use of a phase-locked-loop data separation circuit and write precompensation. Single and double density disk drives can be mixed in the same system.
KIT \$285.00
ASSEMBLED & TESTED \$349.00
BARE BOARD with MANUAL \$55.00
MANUAL \$10.00

SD SYSTEMS VERSA-FLOPPY

KIT \$159.95
ASSEMBLED & TESTED \$239.00

TARBELL FLOPPY DISK INTERFACE

JADE KIT \$190.00
ASSEMBLED & TESTED \$260.00

FLOPPY DISK SPECIAL

TWO SIEMENS 8" DISK DRIVES
JADE DOUBLE-D CONTROLLER KIT
POWER SUPPLY FOR DRIVES
CP/M OPERATING SYSTEM W/BASIC-E
BOX OF 10 DOUBLE DENSITY DISKS
INTERFACE CABLES—A \$1594.95 VALUE.
JADE SPECIAL \$1225.00

FLOPPY DISK DRIVES

NEW BASF MINI-FLOPPY \$319.95
Shugart SA400 compatible but only two-thirds the size! 40 track, double density 5 1/4" drive. Very low power consumption!

MPI B51 5 1/4" DRIVE \$295.00
Single or double density, up to 40 tracks, track-to-track access time of 5ms, Shugart SA400 compatible.

MPI B52 5 1/4" DRIVE \$450.00
Double-sided version of MPI B51.

SHUGART SA400 5 1/4" DRIVE \$325.00
Single density, 35 track.

SIEMENS FDD100-8 8" DRIVE \$495.00
Certified double density Shugart 801R replacement. Runs much cooler and quieter.

SIEMENS FDD200-8 8" DRIVE \$575.00
Double-sided, double density version of FDD100-8.

SHUGART 801R 8" DRIVE \$575.00
Hard or soft sectored, 400K byte drive.

PERSCI 277 DOUBLE 8" DRIVE \$1595.00
Limited quantity with slim line case & power supply.

POWER SUPPLIES

For a single 5 1/4" disk drive.

PSD-249A \$52.00

For a single 8" disk drive.

PSD-205A \$89.95

For two 8" disk drives.

PSD-206A \$125.00

For Rockwell AIM-65.

PSX-030A \$59.95

For KIM-1 or SYM-1.

PSX-020A \$59.95

CP/M 2.0

Digital Research has done it again! This new release of their industry standard disk operating system is bound to be an even bigger hit than the original version. All of the fundamental file-size restrictions of release 1 have been eliminated, while maintaining full compatibility with the earlier versions. This new release can be field-configured by the user for a single mini-disk up through a multiple drive hard-disk system with 128 megabyte capacity. Field configuration can be accomplished easily through use of the Macro Library (DISKDEF) provided with CP/M 2.0.

A powerful operating system for only \$150.00

INTEGRAL DATA SYSTEMS MODEL 440 PRINTER THE PAPER TIGER

Up to 198 CPS
1.75 to 9.5 inch adjustable tractor feed.
Parallel and serial interface.
98 character ASCII set
132 columns- 6 or 8 lines/inch
Eight software selectable character sizes.
110, 300, 600, 1200 baud.
PRM-33440 \$995.00
For the Graphics Option with 2K Buffer add \$199.00

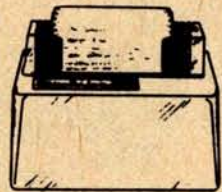

JADE JP80-T PRINTER HARD COPY.....EASY PRICE!

JADE is proud to announce the low-cost solution to your hard copy needs. The JADE JP80-T printer is a high quality 80 column dot matrix printer with an adjustable width tractor feed mechanism. We are certain that you can not get a better printer in this price range!
FAST-150 cps print speed, 80 columns per line.
VERSATILE-adjustable tractor feed 2" to 10".
Upper and lower case 96 character ASCII set.
5 X 7 dot matrix with software selectable character widths.
Centronics-type parallel interface.
Interface/cables available for most popular microcomputers.
PRM-27081 \$749.95

CENTRONICS 730 PRINTER THE ANY-PAPER PRINTER

This printer can use roll paper, fanfold paper, or single sheets because it is equipped with both friction feed and pin feed mechanisms.
RS232 or parallel interface.
96 ASCII character set, upper and lower case.
80 characters per line, 7 X 7 dot matrix.
50 cps print speed.
Weighs less than 10 pounds!
PRM-15730 \$950.00

EXIDY SORCERER

FREE 12 INCH B & W MONITOR WITH EVERY 16K SORCERER

Flexibility is the key. The Sorcerer Computer gives you the flexibility of using ready-to-run, pre-packaged programs or doing your own thing and personalizing the programs for yourself! Whichever you choose. The Sorcerer is the personal computer that speaks your language.

The Sorcerer also provides full graphics capabilities. Each character formed by an 8 x 8 dot cell, can be programmed as a graphic symbol set. High resolution (512 x 240 addressable points) gives a total of 122,880 locations for super animation and extremely light plotting curves. The alphanumeric set gives 64 x 30 characters on the video screen.

With 16K of memory \$1150.00

LEEDEX MONITOR \$139.00

- 12" Black and White
- 12 MHZ Bandwidth
- Handsome Plastic Case

JADE DISK CABLES

MINI-DISK CABLE KIT—Connects two 5 1/4" mini-floppies to your disk controller board and power supply. Includes 5' signal cable with three 34 pin edge connectors, plus power supply connectors and cables. WCA-3431K \$34.95

SIGNAL CABLE ONLY—Connects one 5 1/4" drive to edge type controller card. WCA-3421A \$24.95
For two 5 1/4" drives. WCA-3431A \$29.95

8" DISK CABLE KIT—Connects two 8" disk drives to edge type controller card such as the Versafloppy and Double D. Includes 5' signal cable with three 50 pin edge connectors, plus power supply cables and connectors. WCA-5031K \$38.45
8" DISK CABLE KIT—Same as WCA-5031K except controller end of signal cable has a pin type connector such as the Tarbell controller. WCA-5032K \$38.95

PLACE ORDERS TOLL FREE

800-421-5809 CONTINENTAL U.S.
800-262-1710 INSIDE CALIFORNIA

TEXAS INSTRUMENTS

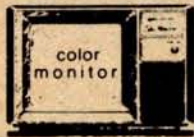

TI-99/4



High quality 13 inch color monitor!
Up to 72K total memory capacity.
16-color graphics capability - easy to access high resolution graphics have special features that let you define your own characters, charts, graphs, etc.
Music and sound effects - build three-note chords and adjust frequency, duration and volume quickly and simply. Five full octaves. Built-in equation calculator—Unique convenience feature helps you find quick solutions to everyday math problems, as well as complex scientific calculations.
Programs are sealed securely in SOLID STATE SOFTWARE COMMAND MODULES. These ROM pack actually add memory to the TI-99/4 so that the console's memory can be utilized for user input. **SYO-8994A** **\$1150.00**

**SD SYSTEMS
Z-80 STARTER KIT**

Based on the powerful Z-80 CPU, this kit is an ideal introduction to microprocessors. It has an on-board keyboard and display, plus cassette tape interface, and expansion provisions for two S-100 connectors. This "Do-it-all-Board" will also program the 2716 2K Kit **\$249.95**
Assembled and tested **\$439.00**

**SD SYSTEMS
SBC-100**

An S-100 single board computer. Z 80 CPU with 1024 bytes of RAM 8-32K bytes of PROM Serial I/O port
Kit **\$239.95**
Assembled **\$369.95**

**Solid State Music
I/O 4**

2 Serial and 2 Parallel I/O
Ports S 100 with full hand shaking
JADE Kit **\$149.95**
Assembled **\$199.95**
Bare Board **\$29.95**

**PARALLEL/SERIAL
INTERFACE**

S-100 compatible, 2 serial I/O ports, 1 parallel I/O
Kit **\$124.95**
Assembled & Tested **\$179.95**
Bare Board W/ Manual **\$30.00**

PROTO BOARD

Includes gold plated fingers. S-100 size, holds 72-116 pin dips, accommodates all 8 thru 40 pin dip packages. Reg. 19.95
TSXA-140B **\$16.95**

SYM-1

6502- Based single board computer with keyboard/display. KIM 1 hardware compatible, complete documentation
SYM-1 CPK-5002A **\$245.00**
SYM-1 CASE, ENX-000005 **\$39.95**

**JADE'S NEW MOTHERBOARDS
THE ISO-BUS**

The only motherboard available today that is designed to IEEE S-100 Bus Standards—a unique network theory of design in which each signal line is surrounded by current mirrored ground lines, significantly reducing RF radiation virtually eliminating crosstalk. No need for active termination. The perfect foundation for a 4MHz system.

6-SLOT	
BARE BOARD	\$24.95
KIT	\$49.95
ASSEMBLED & TESTED	\$59.95
12-SLOT	
BARE BOARD	\$39.95
KIT	\$89.95
ASSEMBLED & TESTED	\$99.95
18-SLOT	
BARE BOARD	\$59.95
KIT	\$129.95
ASSEMBLED & TESTED	\$149.95

**JADE
MEMORY EXPANSION KITS
FOR
TRS-80 APPLE EXIDY**

Everything you need to add 16K of memory to your computer. Your kit comes neatly packaged with easy to follow instructions. In just minutes your computer is ready to tackle more advanced software.

\$82.00

**THE BIG Z
THE NEW Z-80 CPU BOARD FROM JADE**

Features include ● S-100 Compatible available in 2MHz or 4MHz versions. ● On-board 2708, 2716, or 2532 EPROM can be addressed on any 1K, 2K or 4K boundary with power-on jump to EPROM. ● On-board EPROM may be used in SHADOW mode, allowing full 64K RAM to be used. ● Automatic MWRITE generation in front panel is not used. ● On-board USART for synchronous or asynchronous R232 operation (on-board baud rate generator). ● Reverse channel capability on USART allows use with buffered peripherals or devices with not-ready signal.

2MHz Kit: CPU-30200K, 2lbs	\$149.95
Assembled and Tested CPU 30200A 2lbs.	\$199.95
4MHz Kit: CPU-3020 1K, 2 lbs.	\$159.95
Assembled and Tested CPU-30201A, 2lbs.	\$209.95

MICROPROCESSORS

8080A SUPPORT DEVICES	8080 PRODUCT
FB \$16.95	6821P \$5.25
Z80 (2MHz) \$10.95	6828P \$12.00
Z80A (4MHz) \$14.95	6834P \$16.95
CDP1802CD \$24.95	6850P \$4.80
6502 \$11.95	6852P \$7.50
6800 \$12.50	6860P \$9.25
6802 \$20.00	6862P \$12.00
8008-1 \$15.95	6875L \$7.30
8035 \$24.00	6880P \$2.50
8035-B \$24.00	CHARACTER GENERATORS
8080-A \$10.00	2513 Upper \$7.95
8085 \$23.00	2513 Lower \$6.75
TMS9900TL \$49.95	2513 Upper (5 volt) 9.75
	2513 Lower (5 volt) \$13.00
	MCM6571 up scan \$13.00
	MCM6571A down scan \$10.95
	PROMS
	1702A \$5.00
	2708 \$12.95
	2716 \$49.00
	2716 (5v) \$49.00
	2758 (5v) \$30.00
	DYNAMIC RAMS
	4116/416D (200ns) \$12.95
	2104/4096 \$4.75
	2107B-4 \$3.95
	TMS4027/4096 \$4.75
	STATIC RAMS
	21L02 (450ns) \$1.50
	21L02 (250ns) \$1.75
	2101-1 \$2.95
	2111-1 \$3.25
	2112-1 \$2.95
	2114L (450ns) \$8.00
	2114L (300ns) \$9.00
	TMS4044 (450ns) \$8.00
	TMS4044 (300ns) \$9.95
	410D (200ns) \$9.95
	4200A (200ns) \$9.95
	MMS257 (450ns) \$8.00
	MMS257 (300ns) \$9.95

JADE maintains an inventory of over 4000 line items, for price and delivery on items not listed (Including hard to find 74LS devices) please give us a call.

JADE
Computer Products
4901 W ROSECRANS, HAWTHORNE, CA 90250
213-679-3313

PLACE ORDERS TOLL FREE

800-262-1710 800-421-5809
INSIDE CALIFORNIA CONTINENTAL U.S.

WRITE FOR OUR FREE 1979 CATALOG FOR CUSTOMER SERVICE OR TECHNICAL INQUIRIES CALL 213-679-3317

TERMS OF SALE: Cash checks, money orders, and credit cards accepted. Minimum order \$10.00. California residents add 6% sales tax. Minimum shipping and handling charge \$2.50. Prices are for U.S. and Canadian delivery only and are subject to change without notice. For export prices and information send for a JADE INTERNATIONAL CATALOG.



ROCKWELL AIM-65
THE HEAD-START IN MICROCOMPUTERS

A KIM-1 COMPATIBLE MACHINE WITH ON-BOARD PRINTER AND A REAL KEYBOARD!
AIM-65 w/1K of RAM \$375.00
AIM-65 w/4K of RAM \$450.00
8K BASIC in ROM \$100.00
4K Assembler/Editor \$80.00
Power Supply \$59.95
Case of AIM-65 \$49.95



Special Package Price \$599.00
4K AIM-65, 8K BASIC ROM, Power Supply, and Case

**SD SYSTEMS
EXPANDORAM**
Expandable to 32K or 64K

EXPANDO-32K KITS
Uses 4115 (8K X 1, 250ns) Dynamic RAMs. Can be expanded in 8K increments up to 32K

8K \$159.95	24K \$249.95
16K \$199.95	32K \$299.95

EXPANDO-64K KITS
Uses 4116 (16K X 1, 200ns) Dynamic RAMs. Can be expanded up to 64K in 16K increments

16K \$249.95	48K \$469.95
32K \$369.95	64K \$569.95

STATIC RAM BOARDS

8K 2MHz KIT	\$125.95
8K 2MHz ASSEMBLED & TESTED	\$175.00
8K 4MHz KIT	\$149.95
8K 4MHz ASSEMBLED & TESTED	\$180.00
8K BARE BOARD & MANUAL	\$25.00
16K 2MHz KIT	\$250.00
16K 2MHz ASSEMBLED & TESTED	\$325.00
16K 4MHz KIT	\$285.00
16K 4MHz ASSEMBLED & TESTED	\$350.00
16K BARE BOARD & MANUAL	\$35.00
32K 2MHz KIT	\$539.95
32K 2MHz ASSEMBLED & TESTED	\$650.00
32K 4MHz KIT	\$619.95
32K 4MHz ASSEMBLED & TESTED	\$675.00

**SD SYSTEMS
VDB-8024**

An 80 by 24 I/O mapped video board for S-100 systems. An on-board Z-80 processor is used to control all functions. A total of 256 user-programmable characters are available, including 128 characters that are supplied with the board. This is virtually a stand-alone terminal KIT **\$319.95**
ASSEMBLED AND TESTED **\$469.95**

JADE VB-1B

This 64 by 16 memory-mapped video board is ideal for use with word processing software such as the Electric Pencil.
KIT **\$127.50**
ASSEMBLED AND TESTED **\$169.95**
BARE BOARD/MANUAL **\$35.00**

**VECTOR GRAPHICS
FLASHWRITER II**

The ultimate memory-mapped 80 character by 24 line video board, the Vector Graphics FWII has many advanced features: Onboard parallel keyboard port, Power-on jump circuit, 8 X 10 dot character matrix, and the optional ability to program your own characters and/or graphics symbols. This is THE perfect board for text editing systems.
ASSEMBLED AND TESTED **\$320.00**

**NOVATION CAT
ACOUSTIC MODEM**



Features include 300 Baud Answer/Originate, Bell 103
Assembled and Tested **\$189.00**

& Smart Foxy

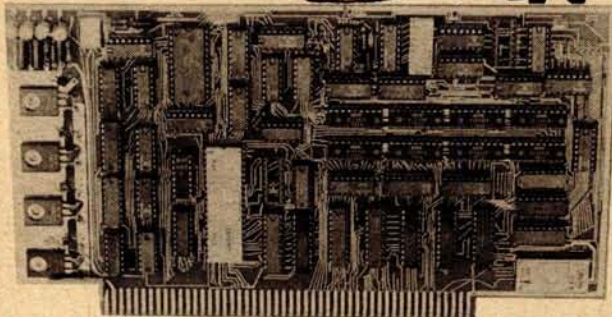
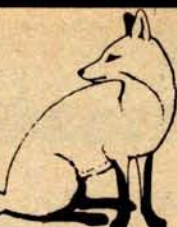

Venus 2001 Video Board

Assembled & Tested
\$259.95 • Complete
Unit with 4K Memory
and Video Driver on
Eprom assembled
and tested **\$339.95**

- OPTIONAL: • Sockets \$10.00
• 2K Memory \$30.00
• 4K Memory \$60.00
• Video Driver Eprom \$20.00

kit \$ **199⁹⁵**

• S-100 plug-in • Parallel keyboard port

On board 4K Screen Memory (Optional). On board Eprom (Optional) for Video Driver or Text Editor Software.

Up and down scrolling through video memory Reverse Video, Blinking Characters.

Display: 128 ASC11 Characters 64 X 32 or 32 X 16 Screen format (Jumper Selectable). 7 by 11 Dot Matrix Characters.

American or European TV Compatible
(CRT Controls Programable) Dealer Inquiries Invited

32-K Static RAM \$499. KIT

- S-100 Plug-In • Kit includes P.C. board, all parts and assembly manual • Uses 2114L, 450 nS.
 - I.C. sockets - \$20.00
- P.C. BOARD BY S-100 CO.

16-K Static RAM \$249. KIT

- S-100 Plug-In Kit includes P.C. board, all parts and assembly manual. Uses 2114L 450 nS.
 - Sockets - \$10.00
- Add \$40.00 for 300 nS (4MHz) RAMS
P.C. BOARD BY WAMECO

Z-80 CPU \$125. KIT

- S-100 Plug-In Kit includes P.C. boards, all parts and assembly manual.
- FEATURES:** 2MHz operation • S-100 plug-in
• Power-on jump • On board provision for 2708 (optional at \$12.95).
- P.C. BOARD BY ITHACA AUDIO

ASCII Keyboard Kit \$79.95



Assembled and Tested \$95.95

- Single +5V Supply • Full ASCII Set (Upper and Lower Case) • Parallel Output • Positive and Negative Strobe • 2 Key Rollover • 3 User Definable Keys • P.C. Board Size: 17-3/16" X 5" • Control Characters Molded on Key Caps • Optional Provision For Serial Output
- OPTIONAL: Metal Enclosure \$27.50 • Edge Con. \$2.00 • Sockets \$4.00 • Upper Case Lock Switch \$2.50 • Shift Register (For Serial Output) \$2.00

Dealer Inquiries Invited

Apple II I/O Board Kit

Plugs into Slot of Mother Board

- 1 8 Bit Parallel Output Port (Expands to 3 Ports) • 1 Input Port • 15mA Output Current Sink or Source • Can be used for peripheral equipment such as printers, floppy discs, cassettes, paper tapes, etc. • 1 free software listing for SWTP PR40 or IBM selectric.

PRICE: 1 Input and 1 Output Port \$49.00
1 Input and 3 Output Ports \$64.00

Dealer Inquiries Invited

new! A DREAM COME TRUE!

Introducing: **30 MHZ**

**DUAL TRACE
PORTABLE
SCOPE**

for an \$ **555.**
amazing

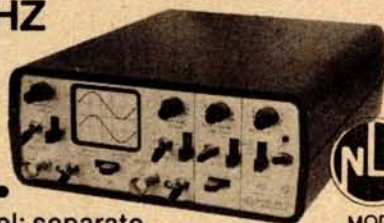

MODEL
MS 230

- Dual trace 2-channel; separate, chopped or alternate modes. • 30 megahertz bandwidth. • External and internal trigger.
- Time base - 0.05, Microseconds to 0.2 SEC/div 21 settings • Battery or line operation.
- Line synchronization mode.
- Power consumption less than 50W. • Vertical gain - 0.1 to 50 volts/div - 12 settings. • Size: 2.9" H 6.4" W 8.5" D. • Weighs only 3.5 lbs. with batteries.
- Complete with input cable and rechargeable batteries and charger unit.

OPTIONAL: Leather case \$45.00 • 10:1 probe \$27.00 (2 for \$49.00)

MS-215
15 MHZ **Dual Trace Portable Scope** \$399.

MS-15 15 MHZ **Single Trace Scope** \$299.

SHIPPING \$3.50 / California residents add 6% sales tax

ELECTRONICS WAREHOUSE Inc.

15820 Hawthorne Boulevard
Lawndale, CA 90260
(213) 370-5551



Unclassified Ads

FOR SALE: Phillips Model P M 3240 Dual-trace, dual time base, 50 MHz oscilloscope. Will consider trade for TRS-80, L II, 16 K. George Cobley, R R 1 POB 95, Central City IA 52214, (319) 842-2653.

FOR SALE: Color monitor, Conrac 19 inch RGB studio monitor. All solid state, low mileage picture tube. \$1200 or trade for plotter. Jim McCord, 330 Vereda Layenda, Goleta CA 93017, (805) 968-6681.

FOR SALE: 26 reels of 1 inch paper tape for ASR33 computer terminal. \$15 plus shipping. Engineering Dynamics International, 8420 Delmar Blvd, St Louis MO 63124, (314) 991-1800.

FOR SALE: TRS-80 printer interface. An RS-232 printer interface which works off of cassette port number 2. May be used with or without the expansion interface. 110 thru 9600 bps and other options. Excellent software support. Tape version \$39.95. Disk version only \$49.95. Gerald Barker, E101 Cedar Oaks Apts, Stillwater OK 74074.

FOR SALE: 20 S-100 connectors, 3 level gold wire wrapped, some are wrapped, little tab on Power and Ground. Fine in IMSAI backplane. \$30 for 20, or \$17 for half. Mark LaCasse, Tang Hall 5F MIT, Cambridge MA 02139, (617) 494-8888 before 1 AM.

FOR SALE: Used Apple II microcomputer. 32 K programmable memory, 2 disk drive with controller, Applesoft BASIC read only memory card 10 K, Centronix 779 printer, tractor feed with interface, programmers aid read only memory, box of ten diskettes, cassette tape drive with interface and ten tapes. Fully floating point BASIC. Less than one year old. Fully warranted and ready to go. \$3800, save \$500. Robert Girardot, 858 Westbourne -6, Los Angeles CA 90069, (213) 675-5393.

FOR SALE: Eight u410D 250 ns memory chips at \$7.50 each (or will swap with 4200A); SA400 minifloppy drive with connector and power supply, \$300. C Tinaztepe, 4301 Spruce St, Philadelphia PA 19104, (215) 243-8530.

FOR SALE: I have 16 K static memory S-100 bus from Digital Research Corp, uses Intel 2114, 450 ns, featuring on board bank select circuitry (Cromemco standard), voltage regulation, selectable wait states, fully buffered, Phantom is jumpered to pin 67, with low profile sockets, professionally assembled but not tested because I need 250 ns programmable memory. Price only US \$300. Peter Lim, 8311 Rideau Dr, Richmond BC, CANADA C7A 4P3.

FOR SALE: ECT 20 slot rack mount card cage with mother board and connectors. Rugged unit: \$50. ECT 30 A power supply (plus 16 V, minus 16 V, plus 8 V, well regulated) \$100. This is designed to mount on the back of the above card cage or may be boxed. ECT 8080 processor board with addressable starting circuit, \$100. Radio Shack (Archer) ASCII keyboard kit (needs a few 74 XX chips) \$20. Factory rebuilt (zero time) Teletype Model 33 printer mechanism, \$140. Amplifier kit to make the TTY-33 into a stand alone printer, \$20. Please enclose SASE with orders or enquiries. I will send COD on request. Check or money order to David Cook, POB 137, Boone NC 28607, (704) 264-3868.

FOR SALE: 150 ns 16 K programmable memory, never out of tube. Limited quantities, eight for \$96. Evan Matre, 2800 SE 185th -26, Aloha OR 97005.

FOR SALE: IMSAI 4 K static, \$70. MITS 4 K dynamic, \$40. Seals 8 K static, \$140. SSM read only memory with MITS DBL and MBL, \$100. MITS disk drive with BASIC and FORTRAN, \$975. MITS-Okidata 110 printer with controller, \$975. All boards fully socketed and factory checked out. Make offer. Also FOR TRADE: Microsoft 8080 FORTRAN MITS disk version for 8080 COBOL or MITS timesharing BASIC. K R Roberts, 10560 Main St Suite 515, Fairfax VA 22030, (703) 378-7266, 591-6008.

TOP DOLLAR PAID for your DEC PDP 11V03 computer system and/or components. VT55 graphics scope. RXV11 floppy disk. Benjamin May, POB 1432, Lakeside AZ 85929.

JUPITER 2 USERS: Jupiter 2 user would enjoy correspondence with others in order to swap software and discuss problems, fixes, etc. Also persons interested in commodity trading programs. M J Kreinik, -28, 424 N Atlantic Av, Monterey Pk CA 91754.

FOR SALE: Heath H8 with 8 K memory, H9 video terminal, two H8-5 cassettes, BASIC and other tapes. \$900 or best offer. Bob Stevenson, 414 E 78th St, New York NY 10021.

FOR SALE: TDL Xitan Alpha II system. Merlin video board interfaced to keyboard, recorder for loading and storing programs. Software-Macro Assembler, Text Editor/Processor, 8 K -12 K BASIC. Assembled and running. Additional hardware includes two iCOM floppy disks, controller board and software, digital cassette, printer and power source. Cromemco kit, analog-digital I/O board, joysticks and software on paper tape. D Memoll, AHRC, 230 Hanse Av, Freeport NY 11520, (516) 546-7700.

FOR SALE: Erasable read only memories, type 5204, 512 by 8 bits, 750 ns access, five minutes/4096 bits program time. Unused; write for specifications. Asking about \$40 for all twelve, or about half of commercial prices. Also have 18 S-100 card edge connectors, wire wrap, asking \$2.50 each or \$36 for the lot. Stephen Hain, 40 Wilshire Dr, Sharon MA 02067, evenings (617) 784-3374.

FOR SALE: Tektronix oscilloscope Model 551, dual beam, 27 MHz complete with B plug-ins and dolly stand. \$500. Tektronix oscilloscope Model 541, 33 MHz with L plug-in. \$450. Teletype Model ASR33 complete with stand. \$500. Kennedy 7 track tape drive, Model 3112, 800 bpi. \$100. Stephan Smolar, 4977 Victoria Av, Montreal Quebec, CANADA H3W 2N2, (514) 483-1983.

FOR SALE: Digital Group standard floppy interface card. Supports one to four devices; NEC PD372 controller chip and documentation included. Expertly assembled and operating. \$250 value for \$160. Seller pays shipping in continental US. First bank draft or money order takes. T L Summers, 539 Tennessee, Lawrence KS 66044.

FOR SALE: User's manual with source/assembly listings for KONVERSE, interpreter and compiler for 6800 systems with MIKBUG or SWTBUG. Derived from FORTH; similar to IPS, described January 1979 BYTE. 2 1/2 K machine code — rest in KONVERSE. 4 + K total. Source file editor, interface PerCom MINIDOS+ included, in 1.7 K. 50 pages. \$10. Russell R Yost, 1825 E Palo Verde Dr, Phoenix AZ 85016.

FOR SALE: Altair 8800 system with up graded power supply, 18 slot mainframe, factory MITS boards: 28 K memory; read only memory card; 2SIO with ports for video display and RS-232 printer; two disk drives and extra controller; Vector Interrupt/Real Time Clock (in kit form); SOROC video display; Teletype Model 43 with RS-232; 4.1 disk Extended BASIC and DOS. All manuals. Prefer to sell as complete system, but will break up if necessary. Ed Wiseman, 346 21st St, Santa Monica CA 90402, Days (213) 644-5643, after 6 PM (213) 393-6393.

FOR SALE: 37 Byte magazines from number 1, 9/75 thru December 1978 except number 3 and number 9. \$55 includes postage insured. Victor Chinn, 1618 Milvia St, Berkeley CA 94709.

FOR SALE: ELF II, giant board plus power supply, modulator, user's manual, programming short course, extras, \$180. Jeff Malakoff, POB 6000, New York NY 10017, (212) 375-6724.

Unclassified Policy

Readers who are soliciting or giving advice, or who have equipment to buy, sell or swap should send in a clearly typed notice to that effect. To be considered for publication, an advertisement must be clearly noncommercial, typed double spaced on plain white paper, contain 75 words or less, and include complete name and address information.

These notices are free of charge and will be printed one time only on a space available basis. Notices can be accepted from individuals or bona fide computer users clubs only. We can engage in no correspondence on these and your confirmation of placement is appearance in an issue of BYTE.

Please note that it may take three or four months for an ad to appear in the magazine.

FOR SALE: Polymorphic 88 with 32 K programmable memory, 12 inch monitor, ASCII keyboard, RS-232 port, cassette port, 2400 bps cassette, 16 by 64 video, BASIC (12 K), Assembler. Lots of application software. Fully documented system. \$1500. Andy Haber, 20 Herbert, Candiac Quebec, CANADA J5R 3R9, (514) 632-5485.

FOR SALE: Dynabyte 16 K dynamic programmable memory module. Compatible 8080/S-100 bus structure. New, unused, tested. Transparent refresh. Two available. Cost \$399, sacrifice for \$245 or 125 pounds sterling, each. B A Herman, 4 Derek Av, Wembley Middlesex, ENGLAND. Can view in US if necessary.

FOR SALE OR TRADE FOR HI-FI EQUIPMENT: RCA Cosmac Super ELF with expanded 8 K of programmable memory with lots of extras like high and low address readouts, video modulator, Ni-Cad battery memory saver and a card cage with space for ten more memory/input/output cards. This plus complete manuals and many programs for only \$150 or best offer. Must sell. Call Dave at (319) 322-6211 or 324-3017.

FOR SALE: A fully populated OSI Challenger III system. Includes 32 K, dual 8 inch floppies, keyboard, video, cassette, graphics, monitor, 16 serial I/O (input/output) board, two 8 bit digital to analog converters, one analog to digital converter, with 8 channel multiplexer, three parallel I/Os, 1 M bytes memory management, software switchable address for all three micros, with connecting cables. Fully operational. Will sell for \$4500. Five free disks of software with purchase includes BASIC, Assembler, Editor, Challenger III operating system, WP-1A, OSI Level 1 and much more. Patricia A Reynolds, (713) 674-8367.

FOR SALE: OSI C2-4P with connected RS-232 port and switch selectable baud rates, works perfectly. Cost \$598, will sell for \$498. Pat Reynolds, (713) 674-8367.

FOR SALE: F8 evaluation kit (MK3850, 3851, 1024 bytes MK4102 programmable memory); edge connector; RS-232C to 20 mA interface, plus 5 V/plus 12 V DC; 2 A/1 A power supply; Lambda LTS-EE-5-0V series pass power supply (5 V DC plus or minus 1.32 A). \$100 or best offer plus shipping. Paul Snigier, 69 Phylis Rd, Raynham MA 02767.

FOR SALE: OSI Challenger III with dual floppy disks, 32 K programmable memory, three processors (6502, Z80, 6800), FDOS, BASIC, Assembler, Disassembler, word processing. Original cost \$3700, sell for \$3000. Bill Gale, 439 S Orange Av, S Orange NJ 07079, (201) 762-8279.

FOR SALE: Complete Honeywell 200 computer system. Includes two magnetic tape drives and controller, one 650 line per minute, 132 column printer and controller, one card reader and punch (IBM 1402) and controller and 64 rolls of printer ribbon. Manuals, cables and spare parts included, \$2500. Also for sale, Frieden 2201 Flexewriter with desk, \$250. Steve Lang, 730 Bridge Apt 7, Davenport IA 52803, (319) 324-0242 after 6 PM.

Reader Service

To get further information on the products advertised in *BYTE*, fill out the reader service card with your name and address. Then circle the appropriate numbers for the advertisers you select from the list. Add a 15-cent stamp to the card, then drop it in the mail. Not only do you gain information, but our advertisers are encouraged to use the marketplace provided by *BYTE*. This helps us bring you a bigger *BYTE*.

Inquiry No.	Page No.	Inquiry No.	Page No.	Inquiry No.	Page No.	Inquiry No.	Page No.
1	AB Computers 276	86	Digital Pathways 159	214	Micro Architect 233	318	Radio Shack 147
10	Addmaster Corp 266	102	Digital Service and Design 263	224	Microcomputer Technology Inc 14	314	Radio Shack Authorized Sales Center 247
8	Administrative Systems 32	95	Digital Research Corp. (CA) 217	220	MicroDaSys 173	324	RNB Enterprises 284
5	Adroit Electronics Inc. 266	100	DRC (TX) 279	221	MicroDaSys 199	325	Rochester Data 241
4	Advanced Computer Products 260, 261	103	DTI 176	222	Microdata Base Systems 85	316	S-100 239
13	AJA 241	104	DTI 177		Micro Diversions 9	320	Sara Tech 97
3	Aladdin 133	105	DYNACOMP 175	218	Micro Focus Ltd 101	326	SCDP 162
6	Altos 145	109	80-US Journal 237	223	Micromail 78	329	Scelbi 184, 185
12	Anderson Jacobson 248	115	Electrolabs 281	204	Micro Mike's 235	330	Seattle Computer Products 223
16	Apparat Inc 14	120	Electronic Control Technology 218		Micropolis 30, 31	319	Michael Shrayder 201
	Apple Insert (between pages 64 and 65)	125	Electronic Systems 257, 258, 259	227	Microsette 266		Shugart Associates 6, 7
14	ARIES Computer Products 188	130	Electronics Warehouse 294	228	Microsette 270	331	Simulations Publications 213
11	ASAP Computer Products 283	131	Excel Company 247	232	MicroSoft 87	337	68 Micro Journal 236
19	ATV Research 170	133	Falcon Publishing 238	233	MicroSoft 95	332	Ed Smith's Software Works 237
7	Automated Computer Software Service 83	132	Henry Fale 270	209	Microtek 19, 166, 174, 182	328	Smoke Signal Broadcasting 13
9	Automated Computer Software Service 53	138	Faragher and Associates 263	225	Microware 193		Software Development and Training 215
18	Automated Simulations 239	135	Farnsworth Computer Center 266	231	Microworks 106	327	Software Dynamics 226
21	Avionic Enterprises Inc. (A.E.I.)	136	Field Service Search 266	234	MicroWorld 96	335	Solid State Music 15
22	base 2 Inc 135	134	FMG Corp 221	235	Midwest Computer Peripherals 238	340	Solid State Sales 276
15	Beckian Enterprises 274	137	Fordham Radio Supply 273	230	Mikos 278	356	Southwest Technical Products Corp C II
33	Beta Business Systems 172	139	H Geller Computer Systems 233	236	Mini Computer Suppliers 194	341	Special Systems Inc 266
	Beta Computer Devices (Div of Measurement Systems & Controls) 230	141	Gimix 45	255	Morrow/Thinker Toys 20, 21	353	subLOGIC 134
31	Biotech Electronics 232	150	Godbout 225	257	Mountain Hardware 153	342	Summagraphics 141
	Bits Inc. 203	151	Go Forms 231	258	Mountain Hardware 118	343	Sun-Flex Co Inc. 263
	BYTE Back Issues 247	152	Graham Dorian C III	260	mpi 215	354	Sunny International 284
36	BYTE Books 123, 127, 128	153	G W Computers Ltd 191	277	Multi Business Comp Sys 266	357	SuperSoft 220
	BYTE Subscriber 245	159	H & E Computers 179	278	MVT 44	359	SuperSoft 233
37	C & S Electronics Mart 209	160	H & K Computer Corp 215	279	National Technical Schools 132	349	Sybox 73
38	California Computer Systems 25	161	Hayden Book Company 211	281	NEECO 138	351	Sybox 74, 75
39	California Digital 291	162	D C Hayes 187	282	NEECO 139	355	Synchro Sound 109
46	Centronics 157		Heath Company 11	280	Netronics 94	350	Systems Engineering Enterprises 195
48	Century Research & Marketing 68	163	Heath Company 49, 56, 57	284	Netronics 115	361	Talos 43
45	Cheops Electronics 204	170	Hobby World 255,	289	New England Recruiters 270	362	TANO 131
47	Chrislin Industries 18	171	Houston Instrument 63	283	Newman Computer Exchange 275	360	Tarbell 71
53	COMPICO 208	172	Houston Instrument 63	290	New Ware 214	365	Technical Software 270
52	COMPRINT (Computer Printers Intl) 228, 229	169	Industrial Micro Systems 119	285	North Star 17	363	Technical Systems Consultants 103
54	CompuServe 51, 120	173	Infinite Inc 170	286	NRI Schools 161	369	Technology Systems South 24
55	Computer Components of South Bay 244	174	Infinity Micro 169	299	Ohio Scientific Instrument C IV	364	Tecmar Inc 69
56	Computer Custom Systems 197	178	Infinity Micro 237	300	Ohio Scientific Instrument 33-40	370	Telecomputing Corp of America 110, 111
	Computer Factory NY 264, 265	175	Information Unlimited 126	291	OK Machine and Tool 5	371	Terminal Data 172
	Computer Hardware 216	179	Inmac 235	288	Oliver Advanced Engineering 245	372	Texas Instruments 29
75	Computerland 117	176	Integral Data Systems 47	287	Omikron 116	368	3/M Company 23
66	Computer Mart of NJ & PA 10	177	Integrand 241		onComputing 112	373	Tiny-C 104
68	Computer Service Center 263	181	Intelligent Systems Corp 55	293	Oregon Software 190	380	Robert Tinney Graphics 41
67	Computer Specialities (CS) 282	182	Interactive Microwave Inc 241	295	Organic Software 164	376	TIS 174
73	Computex 16	183	Internat'l Electronic Equip Corp 180	292	Osborne & Associates 205	374	T L Industries Inc 263
76	CT Micro Computer 54, 181, 240, 245		Intersystems 137	294	Owens Associates Inc 136	375	Tora Systems 170
82	Contract Service Associates 227	180	Intertec Data Systems 77	296	Pacific Exchanges 263	366	Torry Pines Business Systems 270
83	Corvus Systems 27	195	Jade 292, 293	298	Pacific Office Systems 282	313	TransNet 239
	Creative Software 222	200	Jameco 268	297	Page Digital 267	309	TRS-80 Software Exchange 114
80	Cromemco 1, 2	201	Jameco 269	304	PAIA 237	379	Ucatan Computer Store 266
88	CRYPTEXT Corp 242	202	Jim-Pak 289	305	Per Com Data 88	379	US Robotics 42
87	Cybernetic Micro Systems 235	205	Konan 92	306	Per Com Data 89	377	Vector Electronics 146
85	Cybernetics Inc 233		Lifeboat Associates 98, 99, 163	301	Per Com Data 167	378	Vista Computer 262
89	Data Access Corp 158	206	Loweco 270	302	Personal Software 79	384	V R Data 274
91	Data Discount Center 235	208	Macrotronics 172	312	Personal Software 81	387	Wameco 278
92	datafab inc. 183	212	Mass. Institute of Tech (MIT) 270	315	Priority One 286, 287, 288	389	Wintek 263
96	Data Print Publishing 178	212	Maxell Data Products 121		Prodata 151	391	Worldwide Electronics 263
97	Data-Safe Products, Inc 204		McGraw-Hill Book Company 105	322	Program Design Inc 143	392	Xitex 165
93	Datasearch 239	215	Measurement Sys & Controls 171	203	PS Inc 82	401	ZS Systems 194
126	Data-Trans 257	216	Merrimack Systems 270	323	Q-Kit (Div J R Conwell Corp) 234		
127	Datec 189	217	Meta Tech 245	321	Quality Computer Products 266		
128	Delta Products 93	237	Micro America 248	321	Quality Software 247		
99	Diablo (Div of Xerox) 12	213	Micro Ap 219	311	Quest Electronics 277		
101	Digital Engineering 192	219	Micro Applications Group 243	310	RACET Computes 148		
			MICRO Applications & Hardware (MICAH) 192	317	Radio Hut 271		

BOMB— BYTE's Ongoing Monitor Box

*Correspond directly with company.

Article No.	ARTICLE	Page
1	Merrill: Tracing Your Own Roots	22
2	Wolfe: Power Helps Analyze Electric Bills	48
3	Ciarcia: Self-Refreshing LED Graphics Display	58
4	Baker: Picking Up the Pieces	76
5	Maurer: Variables Whose Values Are Strings	90
6	Harman: IBM Compatible Disk Drives	100
7	Gargagliano and Fons: The TRS-80 Speaks	113
8	Condra: Interfacing the S-100 Bus With the Intel 8255	124
9	Powers: The XYZ Phenomenon: Stereoscopic Plotting by Computer	140
10	Ruckdeschel: Curve Fitting With Your Computer	150
11	J Lewis: Low-Level Program Optimization: Some Illustrative Cases	168
12	T Lewis: Some Laws of Personal Computing	186
13	White: Space Game	196
14	Kinzer: Easy To Use Hashing Function	200
15	Parker: Budget Building on a Bare Board	206

JULY BOMB RESULTS

James Albus' *Model of the Brain for Robot Control* moved into first place this month followed closely by Roger Chaffee's *Quest*. Now, if only we could design a program which could play a good Adventure-type game. ■

THE WORLD'S A DIFFERENT

WORLD OF DIFFERENCES

In Computer Software!

Graham-Dorian's Integrated, On-Line Programs Are Fast, Efficient, And Easy To Use.

Rely on Graham-Dorian, a full-line computer software manufacturer, for sophisticated programs — the most detailed on the market today. They're ready to go to work immediately or to be tailored for even more specific needs.

On-line capabilities enable you to make a single entry and update all affected files. An inquiry into a file at any time provides up-to-date information — no batching or sorting of input data.

The programs are easy to use. Messages on the video display guide you each step of the way. Programs make use of indexed sequential and chained files for fast and convenient retrieval of data with efficient use of disk space.

Order in standard eight-inch disk either double or single density, or various mini-floppy formats. Each program contains a free CBASIC-2, plus user's manual and hard copy source listing.

- **Accounts Receivable** — Records invoices, prepares statements and trial balance reports, etc. Automatically reports aging of accounts in periods of 30, 60, and 90 days, with each item listed separately.
- **Accounts Payable** — Vendor lookup and change, entering vendor invoices, writing checks (many options), cash flow analysis, accounts payable check register, and vendor list. Ideal for analyzing expenditures by vendor and by due date.

- **General Ledger** — Includes lookup and change, making journal entries, trial balance, transaction register, chart of accounts, financial statements, and monthly closing.

- **Job Costing** — Provides work order lookup, enters labor transactions, material set-up, progress report of hours, labor distribution report, weekly labor reset, actual versus estimated cost per job.

- **Inventory** — Can be connected with cash register for point of sale inventory control. Number of on-line items limited only by disk space available.

- **Cash Register** — Creates daily sales reports containing information on gift certificates, paidouts, overrings, refunds, and how much in each category a salesperson sold.

- **Payroll** — Handles 100% of all necessary payroll functions including state income tax tables for your state. Ideally suited for both large and small companies.

- **Apartment** — Said one user, "Obviously, this was developed by apartment owners." The package fills virtually all the needs of apartment owners and managers. Ideal for projects with 75 units or more.

- **CBASIC-2** — The most comprehensive and powerful commercially oriented BASIC available today. Enhancements over CBASIC-1: integer variables, multiple line functions, CHAINing with COMMON variables, additional predefined functions, etc. Comes free with any package, or purchase separately.

Compatible with many computers: Northstar, IMSAI, Altos, Cromenco, Industrial Micro Systems, Radio Shack TRS-80, SD Systems, Digital Microsystems, Dynabyte DB8/2, Micropolis MOD II, Vector MZ, and other 8080, 8085, and Z-80-based systems.

See your GDSS dealer or send for information packet and sample runs.



Graham-Dorian Software Systems
A Division of Graham-Dorian Enterprises
211 N. Broadway / Wichita, KS 67202 / (316) 265-8633

Circle 152 on inquiry card.

The Microcomputers you should take seriously.

The Challenger III Series is the microcomputer family with the hardware features, high level software and application programs that serious users in business and industry demand from a computer system, no matter what its size.

Since its introduction in August, 1977, the Challenger III has become one of the most successful microcomputer systems in small business, educational and industrial development applications. Thousands of Challenger III's have been delivered and today hundreds of demonstrator units are set up at systems dealers around the country.

Now the Challenger III systems offer features which make their performance comparable with today's most powerful mini-based systems. Some of these features are:

Three processors today, more tomorrow.

The Challenger III Series is the only computer system with the three most popular processors—the 6502A, 68B00 and Z-80. This allows you to take maximum advantage of the Ohio Scientific software library and the tremendous number of programs offered by independent suppliers and publishers. And all Challenger III's have provisions for the next generation of 16 bit micros via their 16 bit data BUS, 20 address bits, and unused processor select codes. This means you'll be able to plug a CPU expander card with two or more 16 bit micros right in to your existing Challenger III computer.

Systems Software for three processors.

Five DOS options including development, end user, and virtual data file single user systems, real time, time share, and networkable multi-user systems.

The three most popular computer languages including three types of BASIC plus FORTRAN and COBOL with more C3-B
Circle 299 on inquiry card.

languages on the way. And, of course, complete assembler, editor, debugger and run time packages for each of the system's microprocessors.

Applications Software for Small Business Users.

Ready made factory supported small business software including Accounts Receivable, Payables, Cash Receipts, Disbursements, General Ledger, Balance Sheet, P & L Statements, Payroll, Personnel files, Inventory and Order Entry as stand alone packages or integrated systems. A complete word processor system with full editing and output formatting including justification, proportional spacing and hyphenation that can compete directly with dedicated word processor systems.

There are specialized applications packages for specific businesses, plus the vast general library of standard BASIC, FORTRAN and COBOL software.

OS-DMS, the new software star.

Ohio Scientific has developed a remarkable new Information Management system which provides end user

intelligence far beyond what you would expect from even the most powerful mini-systems. Basically, it allows end users to store any collection of information under a Data Base Manager and then instantly obtain information, lists, reports, statistical analysis and even answers to conventional "English" questions pertinent to information in the Data Base. OS-DMS allows many applications to be computerized without any programming!

The new "GT" option heralds the new era of sub-microsecond microcomputers.

Ohio Scientific now offers the 6502C microprocessor with 150 nanosecond main memory as the GT option on all Challenger III Series products. This system performs a memory to register ADD in 600 nanoseconds and a JUMP (65K byte range) in 900 nanoseconds. The system performs an average of 1.5 million instructions per second executing typical end user applications software (and that's a mix of 8, 16 and 24 bit instructions!).

Mini-system Expansion Ability.

Challenger III systems offer the greatest expansion capability in the microcomputer industry, including a full line of over 40 expansion accessories. The maximum configuration is 768K bytes RAM, four 80 million byte Winchester hard disks, 16 communications ports, real time clock, line printer, word processing printer and numerous control interfaces.

Prices you have to take seriously.

The Challenger III systems have phenomenal performance-to-cost ratios. The C3-S1 with 32K static RAM, dual 8" floppies, RS-232 port, BASIC and DOS has a suggested retail price of under \$3600. 80 megabyte disk based systems start at under \$12,000. Our OS-CP/M software package with BASIC, FORTRAN and COBOL is only \$600. The OS-DMS nucleus package has a suggested retail price of only \$300, and other options are comparably priced.

To get the full story on the Challenger III systems and what they can do for you, contact your local Ohio Scientific dealer or call the factory at (216) 562-3101.

SEE OHIO SCIENTIFIC
INSTRUMENT'S AD
SECTION STARTING ON
PAGE 33.

The Challenger III Series from Ohio Scientific.



C3-S1

C3-OEM

OHIO SCIENTIFIC

1333 S. Chillicothe Road • Aurora, Ohio 44202